

THE
WORLD'S
LEADING
DRUM
MAGAZINE

CDG00799



MODERN DRUMMER®

MAY '89

Drums And Percussion For The Amateur To Professional

Dennis Chambers

ROBERT PLANT'S
**Chris
Blackwell**

Bill Berg

GETTING
THE RIGHT SOUND
IN THE STUDIO

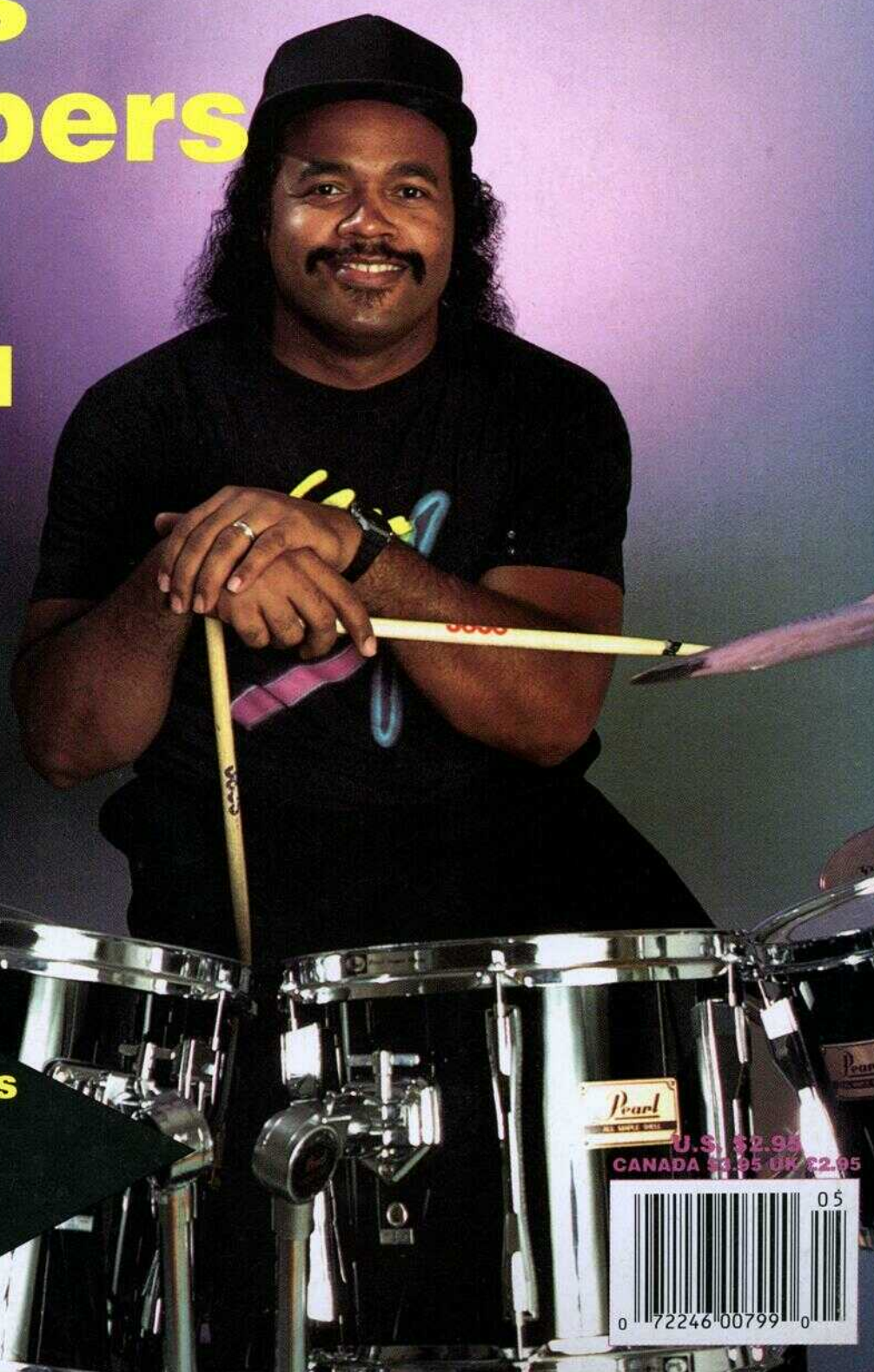

Plus:

- Paul Wheeler
- Pearl Snare Drums
- Electronics On A Budget
- Premier's XPK
- Power Fills On Five Drums!

U.S. \$2.95
CANADA \$3.95 UK £2.95



RICH SOUND FOR THE DRUMMER WHO ISN'T.

Ludwig's Rocker Series—drums for drummers who put more into their music than into their bank accounts. The Rocker line-up has just about every conceivable component, including power toms and bass drums, so you can build a kit that fits your music. And, however you build it, you'll be getting a kit that's pure Ludwig—with the sound and craftsmanship that have made Ludwig the most famous name on drums.

Rocker. They sound expensive, but they aren't.
See your Ludwig dealer.

LUDWIG

A SELMER COMPANY
P.O. Box 310 • Elkhart, IN 46515

Pictured:
Model LR-2447-RM
in silver sparkle.



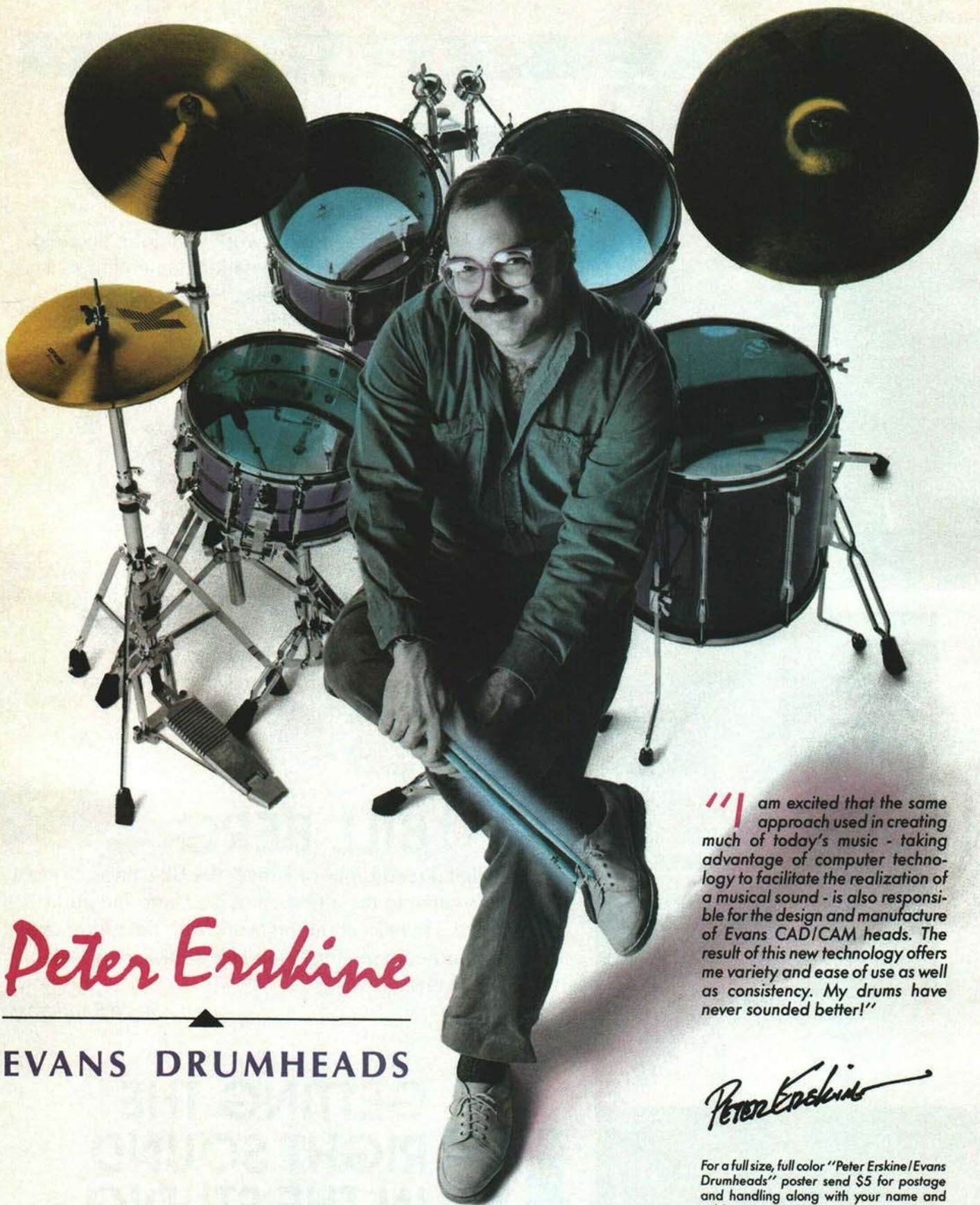

Peter Erskine

EVANS DRUMHEADS

"I am excited that the same approach used in creating much of today's music - taking advantage of computer technology to facilitate the realization of a musical sound - is also responsible for the design and manufacture of Evans CAD/CAM heads. The result of this new technology offers me variety and ease of use as well as consistency. My drums have never sounded better!"

Peter Erskine

For a full size, full color "Peter Erskine / Evans Drumheads" poster send \$5 for postage and handling along with your name and address to:

P.O. Box 58 • Dodge City, KS 67801
316/225-1308 • FAX 316/227-2314



18 DENNIS CHAMBERS

Currently earning praise for his work with John Scofield, Dennis Chambers first attracted national attention as a member of Parliament-Funkadelic. He discusses his background and career, and offers advice on keeping the groove with a bass player.

by Robin Tolleson

24 CHRIS BLACKWELL

While recently on tour with Robert Plant, Chris Blackwell spent a great deal of time triggering various sounds and effects, as well as playing drums. He discusses the background that prepared him for the Plant gig, and talks about the ethics involved in some of today's uses of electronics and sampling.

by Simon Goodwin

28 BILL BERG

The all-digital recordings of Flim & the BB's have brought Bill Berg's name to the attention of jazz fans and audio-philosophers alike. He talks about his work with the group, and recalls memorable sessions with Leo Kottke, Bob Dylan, and Cat Stevens.

by Steve Snodgrass

32 GETTING THE RIGHT SOUND IN THE STUDIO

Tips on setups and tunings to make your drums sound their best in the studio.

by T. Bruce Wittet

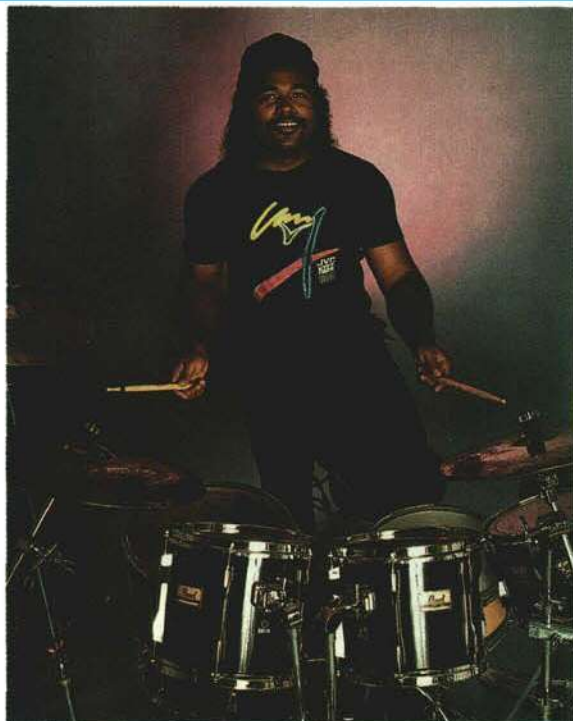

Photo by Ebet Roberts



Photo by Ebet Roberts



Photo by Jaeger Katos

EDUCATION

ROCK PERSPECTIVES

Count!
by *Kenny Aronoff*
44

CONCEPTS

Discipline
by *Roy Burns*
56

BASICS

Multi-Tom Fills On A
Five-Piece Set: Part 1
by *Jim Pfeifer*
58

UNDERSTANDING RHYTHM

Learning Polyrhythms:
Part 3
by *Peter Magadini*
66

ROCK 'N' JAZZ CLINIC

I'll Never Forget The
Time...
by *Rod Morgenstein*
68

MASTER CLASS

Portraits In Rhythm:
Etude #18
by *Anthony J. Cirone*
78

ELECTRONIC INSIGHTS

Electronics On A
Budget
by *J.W. Mucciolo*
86

IN THE STUDIO

On Professionalism
by *Craig Krampf*
90

PROFILES

PORTRAITS

Evelyn Glennie
by *Lauren Vogel*
46

UP & COMING

Paul Wheeler
by *Teri Saccone*
74

EQUIPMENT

PRODUCT CLOSE-UP

Premier XPK Drumkit
by *Bob Saydlowski, Jr.*
38
Pearl Snare Drums
by *William F. Miller*
40

Wuhan Cymbals
by *William F. Miller*
41

NEW AND NOTABLE
102

REVIEWS

ON TAPE
92

DEPARTMENTS

EDITOR'S OVERVIEW

4

READERS' PLATFORM

6

ASK A PRO

12

IT'S QUESTIONABLE

14

DRUM MARKET

106

NEWS

UPDATE

8

INDUSTRY HAPPENINGS

98



EDITOR'S OVERVIEW

The Drumming Fraternity

Of all the nice comments I hear from drummers around the world, the one that gives me the most satisfaction is that *MD* has been instrumental in bringing drummers together into a fraternity of sorts. I hear that quite often, and it's one of the things that has made 13 years of editing *Modern Drummer* such a worthwhile endeavor for me.

It's interesting to note that drummers weren't always particularly friendly towards one another. As a matter of fact, there always seemed to be a strong sense of competitiveness among drummers. Older players might recall the significant number of "drum contests," the "cutting-sessions" of 40 years ago among the bop artists, and the infamous "drum battles." All of this was quite indicative of that "I can outplay you" attitude that apparently existed. The new generation of drummers doesn't share in those values as much. They appear to be much more interested in learning from one another, openly sharing ideas, and working towards the common goal of drumming excellence. I see evidence of this everywhere, and perhaps the best example of it was at *MD's* past two Drum Festivals.

Here were 1,000 enthusiastic drummers under one roof for nearly eight hours. They weren't there to encourage one performer to outdo the other, but rather to learn as much as possible from each artist's performance. They greeted the legendary Joe Morello with a rousing ovation as he stepped up to accept *Modern Drummer's* Hall Of Fame Award. And though many were obviously much too young to remember Joe during the Brubeck years, they sure knew who he was, and the display of admiration and respect for this giant among us was overwhelming. A similar sense of camaraderie could be felt in the backstage area throughout the day, as name players from every style of drumming greeted one another with kind words and genuine affection.

Perhaps Dave Weckl expressed it best during his performance at our first Drum Festival, when he stated, "I'm always happy to be a part of something where the 'family of drummers' get a chance to hang. And we are a family." Drummers today certainly do consider themselves part of a family, and place great value on any opportunity they get to learn from one another. It's an attribute we should all be proud of and always maintain. To my knowledge, it's a quality that doesn't exist among any other single group of instrumentalists. Think about it: When was the last time you saw 1,000 trumpet players assemble for eight hours to share ideas, exchange kind words, and applaud each other's work?

I'm happy that *MD* has received some of the credit for changing old attitudes, improving communication between drummers, and bettering the quality of the camaraderie we now share. We've come a long, long way since the days of the "cutting sessions" and the "drum battles," and I'm hopeful that this new, healthier attitude will continue to flourish among our fraternity.

EDITOR/PUBLISHER

Ronald Spagnardi

ASSOCIATE PUBLISHER

Isabel Spagnardi

SENIOR EDITOR

Rick Mattingly

MANAGING EDITOR

Rick Van Horn

ASSOCIATE EDITORS

William F. Miller

Adam Budofsky

EDITORIAL ASSISTANT

Cynthia Huang

ART DIRECTOR

Terry Kennedy

ADMINISTRATIVE MANAGER

Tracy Kearney

ADMINISTRATIVE ASSISTANT

Joan C. Stickel

ADVERTISING DIRECTOR

Kevin W. Kearns

DEALER SERVICE MANAGER

Crystal W. Van Horn

CUSTOMER SERVICE

Ingemarie H. Hays

MAIL ROOM SUPERVISOR

Leo Spagnardi

CONSULTANT TO THE PUBLISHER

Arnold E. Abramson

MODERN DRUMMER

ADVISORY BOARD

Henry Adler, Kenny Aronoff, Louie Bellson, Bill Bruford, Roy Burns, Jim Chapin, Alan Dawson, Dennis DeLucia, Les DeMerle, Len DiMuzio, Charlie Donnelly, Peter Erskine, Vic Firth, Danny Gottlieb, Sonny Igoe, Jim Keltner, Mel Lewis, Larrie Londin, Peter Magadini, George Marsh, Joe Morello, Andy Newmark, Neil Peart, Charlie Perry, Dave Samuels, John Santos, Ed Shaughnessy, Steve Smith, Ed Thigpen.

CONTRIBUTING WRITERS

Susan Alexander, Robyn Flans, Simon Goodwin, Karen Ervin Pershing, Jeff Potter, Teri Saccone, Robert Santelli, Bob Saydlowski, Jr., Robin Tolleson, Lauren Vogel, T. Bruce Wittet.

MODERN DRUMMER Magazine

(ISSN 0194-4533) is published monthly with an additional issue in July by **MODERN DRUMMER Publications, Inc.**, 870 Pompton Avenue, Cedar Grove, NJ 07009. Second-Class Postage paid at Cedar Grove, NJ 07009 and at additional mailing offices. Copyright 1989 by Modern Drummer Publications, Inc. All rights reserved. Reproduction without the permission of the publisher is prohibited.

EDITORIAL/ADVERTISING/

ADMINISTRATIVE OFFICES:

Modern Drummer Publications, 870 Pompton Avenue, Cedar Grove, NJ 07009.

MANUSCRIPTS: Modern Drummer welcomes manuscripts, however, cannot assume responsibility for them. Manuscripts must be accompanied by a self-addressed, stamped envelope.

MUSIC DEALERS: Modern Drummer is available for resale at bulk rates. Direct correspondence to Modern Drummer, Dealer Service, 870 Pompton Ave., Cedar Grove, NJ 07009. Tel: 800-522-DRUM or 201-239-4140.

SUBSCRIPTIONS: \$25.95 per year; \$46.95, two years. Single copies \$2.95.

SUBSCRIPTION CORRESPONDENCE: Modern Drummer, PO Box 480, Mount Morris, IL 61054-0480. **Change of address:** Allow at least six weeks for a change. Please provide both old and new address. Toll Free Phone: 1-800-435-0715.

POSTMASTER: Send address changes to Modern Drummer, P.O. Box 480, Mt. Morris, IL 61054.

A Member Of:



Magazine Publishers of America

ISSUE DATE: May 1989

LACQUER, CHROME AND THUNDER



Special thanks to Frank, Jenny, and Ed at Mills Harley Davidson, Burlington, NJ.

Rock and roll is more than just music. It's an attitude. The look of the streets. The rumble of a big V-twin.

Premier Projector kits are more than just drums. They're a statement of how you feel about your music. The hand-crafted shells have the sound of thunder. The deep lacquer and brilliant chrome have the look of classic beauty.

The development of Projector drums was guided by rock and roll drummers. They wanted them loud—with strong low frequencies—with tough, roadworthy hardware—with a deep lacquer finish.

They got what they wanted—the best looking, best sounding and best performing drums in the world of rock and roll.

If you haven't played Projector drums before, check out a set at your Premier dealer. You'll see what we're talking about. If you appreciate rock and roll, you'll understand. The beauty of lacquer and chrome. The sound of thunder.

Premier Percussion Ltd., Blaby Road, Wigston, Leicester LE8 2DF, England, **Premier Percussion USA, Inc.**, 1704 Taylors Lane, Cinnaminson, NJ 08077

PREMIER
PERCUSSION

Send \$5.00 for a 30" x 40" Projector Lacquer, Chrome and Thunder poster

READERS' PLATFORM

AL FOSTER

If I interpreted the article's introduction correctly, *MD* has been trying to interview Al Foster for several years. I know that I've been writing and *asking for* such an interview for several years. Let me just say that it was worth the wait! The interview [January '89 *MD*] was just the right combination of Al's interesting professional history and his current musical outlook. Al's contribution to jazz drumming has been greatly overlooked by many people, possibly because of his personal humility. He's a great player, and Robin Tolleson's persistence in pursuing him was well justified. Thanks very much for a fine piece!

Ernie Boldark
Green Bay WI

JOHANSSON AND MOLO

I found it very interesting—and not a little ironic—that *MD* would choose to present interviews with Anders Johansson and John Molo in the same issue. Anders represents speed, chops, technical ability, and a certain amount of "flash for flash's sake"—appropriate for Yngwie Malmsteen's speed-rock but not exactly the style of playing that sets one's toes to tapping. John, on the other hand, epitomizes the "keep it basic, make it groove, play it like a drum machine" school of pop drumming, letting no portion of his drumming in any way interfere—or even be noticed—to the detriment of the song his band is playing.

This is not meant as a criticism of either gentleman, because each is doing precisely what is called for in his particular position. It is more a reflection on the incredible diversity of styles that are represented in today's musical market. In fact, I compli-

ment both Anders and John on achieving the status to be included in *Modern Drummer's* pages, and I compliment *Modern Drummer* on the balancing act it constantly maintains, presenting its readers with articles on so many *different* drummers month after month.

Art Selleterman
San Diego CA

WILLIAM CALHOUN

I would like to express my appreciation for the *Up & Coming* article on Living Colour's William Calhoun in the January 1989 issue. Not only did you profile a player with a great sense of groove, you also brought attention to the Black Rock Coalition. How utterly nauseating that the record industry finds it difficult to promote and market certain bands because their skin color does not seem to "match" the type of music they play!

Steven Lederman
Willowdale, Ontario, Canada

CORRECTION FROM MOERSCH

I would like to correct some omissions from your otherwise excellent portrait on Neil Grover in the December '88 issue. The "incredible" mallet part to the New York Shakespeare Festival Broadway production of *The Pirates Of Penzance*, which Neil praises so highly, was created by myself, working with the original Gilbert & Sullivan piano/vocal score and within the instrumentation guidelines specified by the show's superb music director, the late William Elliott. Likewise, the "chromatic" timpani part was created by William Ruyle, now of the Manhattan Marimba Quartet. Bill Ruyle and I played the show from the

early days in Central Park through the entire Broadway run—something over 800 performances. Larry Spivack joined the show on drums when we moved to Broadway.

I highly recommend that any would-be mallet player check out the *Pirates* book, either on the Broadway cast album or in the movie version—both of which I recorded. That mallet part has been the bane and/or joy of many percussionists around the world. After returning from directing the first Australian company, William Elliott told me the Australian percussionists had put a price on my head for writing it. Fortunately, they seemed to have forgiven me by last summer when I made my first solo tour of Australia.

William Moersch
New York NY

SPEED KING SQUEAK DISCOVERED?!

In regards to comments about the notorious "squeaking" *Speed King* pedal in *MD's* review of Ludwig's *Super Classic* outfit [November '88 *MD*], I'd like to offer the following suggestion. Recently, during one of my many determined efforts to find the *Speed King* squeak, I placed a few drops of machine oil on the two rivets that sit at both sides of the reversible heelplate at the base of the footboard. (Though the heelplate is obviously not part of the moving assembly, it does shift slightly with the natural movement of the foot. Yet it is a place one would not tend to think of as needing lubrication.) Within seconds, the squeak vanished! I immediately tried the exact same thing on the second of my two squeaky *Speed Kings*, and got the same results. Nei-

Continued on page 88

YOUNG, FAST & SCIENTIFIC

System D8. The easy way into the expressive universe of Yamaha electronic percussion.

Customize D8's powerful, realistic PCM sounds into anything you want with nearly limitless editing.

Use D8 with different Yamaha tone generators to expand into the popular world of FM synthesis. And it's MIDI, so you can patch into any kind of music system.

D8 pads feel right, with plenty of natural rebound and dynamic stick response.

D8. Cost-competitive Drummer-Designed percussion technology from Yamaha.



100
1887-1987

A Century of Quality

For a free copy of the Yamaha Drum Catalog, enclose \$3.00 for postage and handling and write to: Yamaha Music Corporation, USA, Drums, Guitars and Amplifiers Division, P.O. Box 6600, Buena Park, CA 90622.

YAMAHA®

BOBBY BLOTZER/TALKING YAMAHA DRUMS



Bobby Blotzer/Yamaha. Acoustic Turbo Tour shells cut through in any session or arena. Electronic D8 System with a whole new spectrum of sounds removes all limits from the music.

"The reason I'm playing Yamaha is when Ratt rolls into town, I know I'll have the biggest acoustic drum sound I can get. And my new D8 Electronic Percussion System has a large variety of drum sounds that are unmatched."

Bobby Blotzer: Rock hard foundation that drives the multi-platinum sound of Ratt. He mixes all the musical possibilities to get the best out of each song.

Look for Bobby and the monster sound of Yamaha on Ratt's New '88 LP and World Tour.



100
1887-1987

A Century of Quality

For a free copy of the Yamaha Drum Catalog, enclose \$3.00 for postage & handling and write to: Yamaha Music Corporation, USA, Drums, Guitars and Amplifiers Division, P.O. Box 6600, Buena Park, CA 90622.

YAMAHA®

Pat Torpey



Photo by Lissa Wales

One Saturday morning last October, Pat Torpey was just waking up when the phone rang. It was Herbie Herbert, manager of his band, Mr. Big. But before Pat could get to the phone, his answering machine kicked on, and Herbert left a message that Chris Blackwell had broken his wrist and Robert Plant was in need of a drummer. The next day, Pat was auditioning in Chicago.

"I got on the plane at 10:30 in the morning, flew for about five hours, and a limo picked me up and took me right to the rehearsal hall," Pat recounts. "Robert wasn't there, but I met everybody in the band, and we started playing through some of the stuff to see how it felt. After about an hour and a half, Robert walked in, shook my hand, and said, 'Let's get down to work and see how it sounds.' We played for about an hour; he was just checking me out to see how I would interplay with everybody, personally as well as musically. He came up to me and said, 'Well Pat...' and I figured he was going to say, 'We have another couple of guys we want to try out,' but he said, 'I really like the way you sound. Do you want to do it?' I said yes, and we started rehearsing that evening.

"Chris was playing with one hand, and he put some songs down on tape so I could listen to them on my *Walkman* at the hotel that night, and I made a book of notations—cheat sheets—which I used for about six shows. Of course, when you're reading and playing at the same time, you don't feel as loose about really digging in, so I was glad when I could toss the book and sink my teeth into it and really start

playing."

According to Pat, the material required a lot of different capabilities. "Some of Robert's solo stuff requires a little lighter touch, a little more finesse, and I would say that Chris is a lighter player than I am, in terms of finesse and technique. I'm more into really attacking the drums. But I was very grateful I had spent a lot of time in my practice room, because there were a couple of moves where I really had to have good independence between my limbs, and I thought, 'I'm sure glad I worked on something like this!' Chris has an unorthodox setup, so some of the things he did didn't come naturally to me, but I had to figure out a way to do them, playing the kit the 'normal' way. The song 'Billy's Revenge' is kind of a rockabilly in six that goes to four. That probably had the strangest moves I had to make, but it worked out alright."

By now, Torpey, Billy Sheehan (bass), Eric Martin (vocals), and Paul Gilbert (guitar), who comprise Mr. Big, should have recorded the band's debut offering. "Our music is still somewhat in the embryonic stage" says Pat, "but it's pretty straight-ahead rock, as in *Free or Bad Company*. But there is a little more technical side to it because of Billy and Paul, who are amazing players." In addition to Mr. Big, Pat can also be heard on Jeff Paris's LP, the last Ted Nugent offering, and on Impellitteri's album.

—Robyn Flans

Greg Roberts

The band known as B.A.D.—short for Big Audio Dynamite—was formed from the ashes of *The Clash*, and has, over the span of four years, gone on to capture a new audience as well as a contingency of *Clash* fanatics. The funkified innovations of B.A.D. are a percolating mixture of dance-oriented, hard-edged numbers, and rhythmic vignettes conjuring up spaghetti westerns and street-beat scenarios.

The group's percussionist, Greg Roberts, landed his gig when he placed an ad in Britain's *Melody Maker*, ex-*Clash*/B.A.D. founder Mick

Jones solicited for a drummer in the same issue. As the story goes, Roberts was so brimming with confidence upon meeting Jones that he informed the guitarist that he was going to be his drummer. Roberts was right on the money, as was Jones for hiring him, and Greg has been a definite asset to the group ever since. Nevertheless, Greg confesses that although he was into several *Clash* tracks when the group was together, he was not a diehard fan.

"To be honest," admits Roberts, "I hadn't risen with the punk explosion. At 17, when I decided to take up the drums properly, I formed a band with my brother. We were a funk band that basically concentrated on the cabaret circuit. I eventually gave it up for a couple of years and worked a regular job before taking it up again. I had also played in as many bands as possible—reggae, jazz, Latin—and when I returned to playing, I played as many gigs and sessions as I could here in London. Then I went down to South America with an artist I was playing with to make a record, when I realized I was doing this in bits and pieces and that, to get the most out of it, I would have to dedicate all of my energies into a band. That's when I joined B.A.D."

The group has used electronics on their three LPs and during their live shows. Had Roberts previously delved into computers and drum machines? "Before I joined, no," he responds. "Mick gave me a drum machine and said, 'Do something with it.' I got into programs and playing with samplers, and that progressed to my messing around with keyboards. Soon, I started getting into writing bass lines, chord structures, and lyrics. It all came about from the experimentation with the machines. There are several songs on the last album [*Tighten Up Volume '88*] that I had a hand in writing."

Additionally, Greg has done some outside producing and several remixes, and he's getting more involved with songwriting. "I'm a drummer, but I can't be defined strictly as that," he states. "I'd hate to be

typecast, and just as B.A.D. is an amalgam of all our different backgrounds—punk, funk, reggae, jazz, and films—there are also different interests and personalities within all of us as individuals. I'm not saying that I want to end up doing things only on one side of the board, but I think the variety is good because I have more than one direction ahead of me. Right now, I'm really into composing and soundscaping, but who knows where that will lead?"

—Teri Saccone

Tommy Campbell



Since his *MD* interview back in July of '85, Tommy Campbell has made a few changes in his life. At that time, he was living in Boston, teaching at Berklee, and working with Sonny Rollins on a regular basis. Last fall Tommy made a major change by moving to New York City.

"I had it very comfortable," says Tommy about his life in Boston. "I enjoyed teaching at Berklee, but I was becoming known more as a teacher and not as a player. I love to teach, but I'm a *player*." His new digs are giving him the opportunity to do just that. "Living in New York is working out great. I'm near all the clubs. When I'm not working, I can hang out at the clubs and play a lot of late-night jam sessions."

The most exciting thing that happened for Tommy after his move was the recording of his first solo album. Pony Canyon, the Japanese jazz label, will be releasing the album in Japan, and is currently making arrangements for U.S. distribution. According to Tommy, "Yoshiaki Matsuo, the president of Pony Canyon, used to



RS PRO

A new direction in drums
for players ~~at~~ the edge

over

STEVEN ADLER

GUNS N' ROSES



on RS PRO

At your authorized TAMA dealer NOW!

TAMA®

For a FREE copy of Tama's new RS line catalog, send your name and address on a postcard to TAMA: Dept. RSMD1, P.O. Box 886, Bensalem, PA 19020 • 3221 Producer Way, Pomona, CA 91768-3916 • P.O. Box 2009, Idaho Falls, ID 83403. In Canada: 6969 Trans Canada Highway, Suite 105, St. Laurent, Quebec, Canada H4T1V8.

be in Sonny Rollins' band years ago, so we knew each other through Sonny. Two years ago, Yoshiaki put together his own label. He has signed jazz artists such as Kenny Drew Jr., Mark Soskin, Donald Brown, Alan Dawson, and others. When I came to New York, he told me he wanted me to put together a group and record for him."

The direction of his album was heavily influenced by the record company. "They wanted a straight-ahead record because that's what the label is known for. I'm not really a traditional jazz drummer, but when someone offers you the chance to do it, why turn it down?" Even though Tommy is primarily known for his tremendous fusion chops through his work with people like John McLaughlin, he has worked with Dizzy Gillespie and Sonny Rollins, so playing bebop is not a problem. "I would say I have a lot of experience playing that way, but I never really studied enough of the traditional styles. It's not my forte, but the label didn't want a fusion album, and I just looked at it as a challenge. I tried to blend the different playing styles together. Hopefully I came up with something fresh; I think I did."

The album was recorded live to two-track by noted engineer David Baker. "There were no overdubs, even though one or two would have been nice," jokes Tommy. "The album has a live feel to it, and I was very happy with the sound of the drums." The entire project was completed in a grueling three-day period. "We rehearsed on a Thursday, and we recorded on Friday and Saturday. They were all 12-hour days. Being on that kind of schedule puts a lot of pressure on everybody to make things happen. I learned a lot about being a leader in that situation. I tried to give everybody as much musical freedom as possible, but when there were disagreements, I had to stand up and take charge."

Tommy is planning to take his group on a tour of Japan to support the album. Over the last few months he's also played a few gigs with Sonny Rollins, whom he still works with from time to time. In addition, Tommy was in Italy last

December for a short clinic and concert tour. And with all of this happening, he's somehow finding the time to teach at Drummers Collective on a semi-regular basis. It sounds like the decision to move to New York was a good one!

—William F. Miller

Johnny "Bee" Badanjek



Photo by Bots Alford

"I'm keeping busy," says Johnny "Bee" Badanjek. "I'm playing a lot of drums these days. But my real goal is a record deal. I've got a lot of songs and a lot of ideas I want to put on vinyl."

In the meantime, though, Badanjek has teamed up with old friend Mitch Ryder, who is back on the road with a new version of the Detroit Wheels. Badanjek has also played on Ronnie Montrose's latest LP, *Speed Of Sound*.

It was Montrose who produced and played guitar on Badanjek's five-song demo, which is currently being shopped to record companies. "Ronnie heard some of the songs I wrote and said, 'Yeah, you've got to get in the studio, and I'll go in with you.' He's even interested in producing my album, once I get a contract."

According to Badanjek, E Street Band members Max Weinberg and Nils Lofgren have also expressed interest in helping him with his solo effort. "It could be a great thing," continued Badanjek. "If the people who say they want to play on it actually do, it ought to be a fun time."

Badanjek described his newest songs as "straight-ahead rock 'n' roll in the Bryan Adams vein. I went through a period when a lot of the stuff I was writing sounded like something Iggy Pop or INXS would be comfortable with. But now I'm

back to the roots, both as a writer and drummer."

As for his role with Ryder and the Detroit Wheels, Badanjek said he would continue to tour and record with the group. Earlier this year the band recorded a live double album called *Red Blood, White Mink*. It was released by Line Records in Europe and is available in the U.S. as an import.

Ryder, Badanjek, and the rest of the Wheels hope to record a studio LP this year. "Right now it looks like Dave Edmunds might be the producer," said Badanjek. "Now this record could be a really good time, too."

—Robert Santelli

News...

Terry Bozzio can be heard on Mick Karn's LP. He has also been working with Group '87, as well as recording an album and touring with Jeff Beck.

Tris Imboden and Alex Acuna on Michael Paulo's LP. Tris has also been doing dates with Al Jarreau.

Glenn Symmonds on tour with Eddie Money.

Carl Allen recently worked with the Freddie Hubbard Quintet and the John Stubblefield Quartet.

Since leaving Toshiko Akiyoshi's Orchestra, **Jeffrey Hirshfield** has been doing gigs with Toots Thielemans, Jim Hall, Mike Stern, Eddie Daniels, Randy Brecker & Eliane Elias, Fred Hersch, Mark Cohen and Gary Peacock, Marian McPartland, Bill Mays, and Vic Juris.

The Jerry Tachoir Quartet with **Wayne Killius** on drums recently recorded their fourth album.

Tony V. De Augustine has recently been performing with Ben Vereen, Clint Holmes, Ann Jillian, and Debbie Reynolds, as well as recording drums and percussion for the theme to TV's *Incredible Sunday*.

Paul Leim on new albums by Kenny Rogers, Billy Burnett, Baillie & the Boys, Lyle Lovett, the Gatlin Brothers, Tom Kimmel, Anne Murray, Randy Travis, Barry Manilow, and Bill Medley.

Mario Grillo in Europe with

Machito Orchestra.

Omar Hakim's first solo album will be released soon on GRP Records.

Mark Zonder has joined Fates Warning, now working on their sixth album.

Les DeMerle has a new, self-produced album out called *The Les DeMerle Band: Spontaneous Combustion (Featuring Bonnie Eisele)*. A departure from his work with Transfusion, the new album features only a rhythm section and vocalist Eisele. Les can also be seen on two new videos from M&K Productions entitled *Les DeMerle: Rock/Fusion Drumset Application (Lesson #1 and Lesson #2)*. The members of Transfusion join Les on the tunes demonstrated on the video, and charts of all the music are included.

Drummer **Zoro** is working with Bobby Brown. Congratulations to Zoro and Andrea Tipon, who recently tied the knot.

Polygram Jazz recently announced the release of **Terri Lyne Carrington's** debut album, *Real Life Story*, on the Verve Forecast label. Carrington performs on the drums and vocals, and **Don Alias** is on percussion. Look for **Bill Summers'** new release.

Michael Blair playing percussion on two tracks for Syd Straw, Leo Kottke's current release, and Elvis Costello's recently released album.

Joey Heredia back from touring with Herb Alpert. He can be heard on Frank Gambale's live LP and on Billy Childs' album, and he has been working with Scott Henderson's Tribal Tech. Techno-junkie report: **Peter Erskine and Vinnie Colaiuta** recently announced plans to incorporate FAX machines into their electronics racks.

Congratulations to Chris and **Billy Amendola** on the birth of their son, Matthew Vincent. Billy has recently recorded with True Blue, Dunn Pearson, Regina, Marlene Shaw, and Brian Drux.

Jeff Ballard touring with Ray Charles.

Dan Atherton recently completed a tour with New Edition, and is now touring with Levert. Yes, **Bill Bruford** recently recorded with Jon Anderson, Rick Wakeman, Steve Howe, and Tony Levin.



STRIP DOWN AND PLAY.

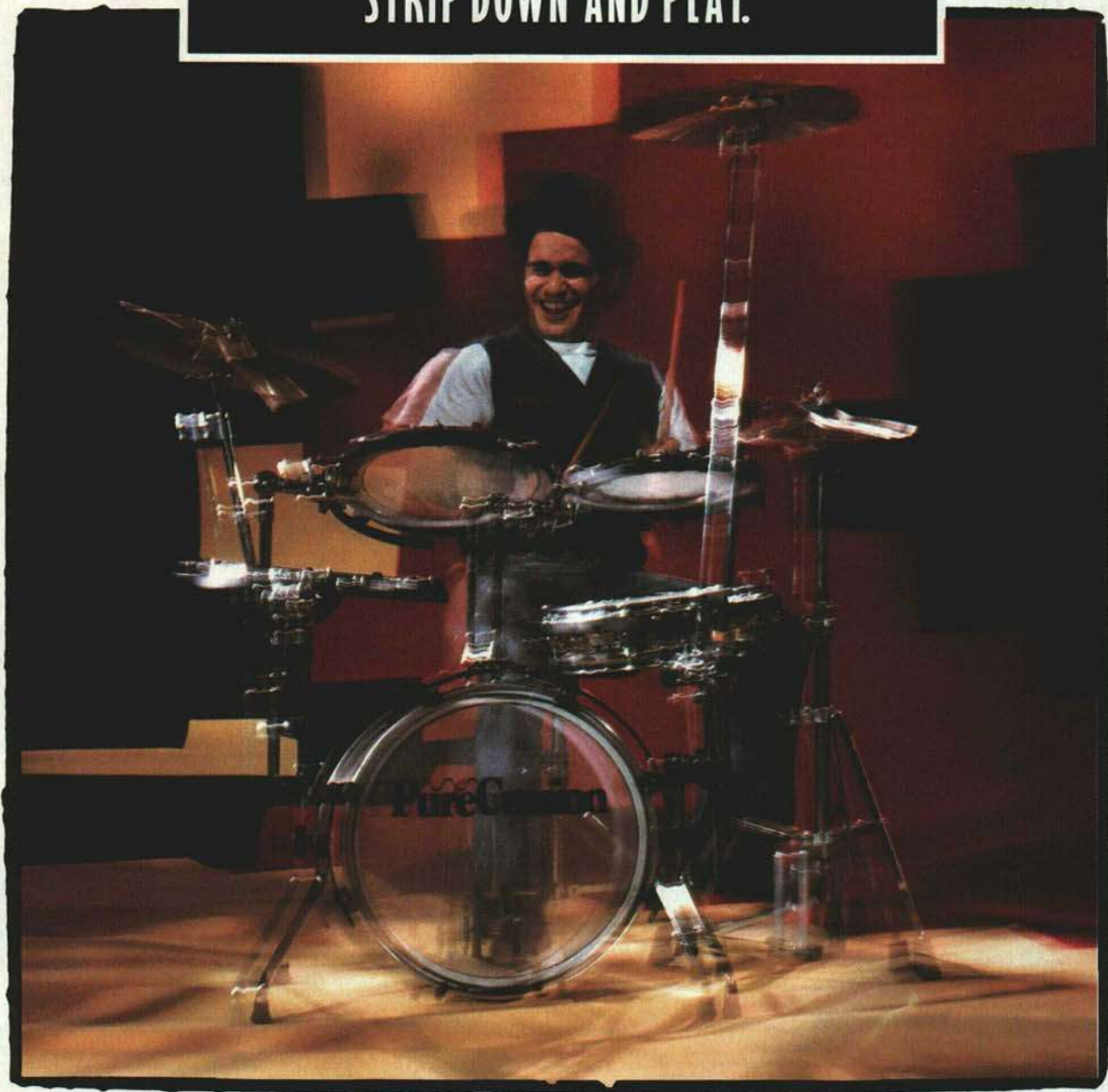

■ They're stripped down. They're lean and mean. They're the drummer's own set of compact discs. ■
■ They're PureCussion Drums. PureCussion doesn't have shells. It's a set of heads suspended by our famous RIMS® Drum Mounts. ■ Almost all the top players are attached to RIMS—a patented mounting system that allows the head maximum resonance. ■ With RIMS, PureCussion Drums play, respond, and resonate like traditional acoustic drums. ■ But sound might be the only thing traditional about this set. They're transparent, futuristic, and light. ■ And they pack up into a single case in just about ten minutes flat. ■ So next time you're on the bandstand, strip down and play—PureCussion Drums. ■ Find out more. Call (800) 328-0263. ■

PURECUSSION™ DRUMS
Time Signature For The Next Wave.™

BILL BRUFORD

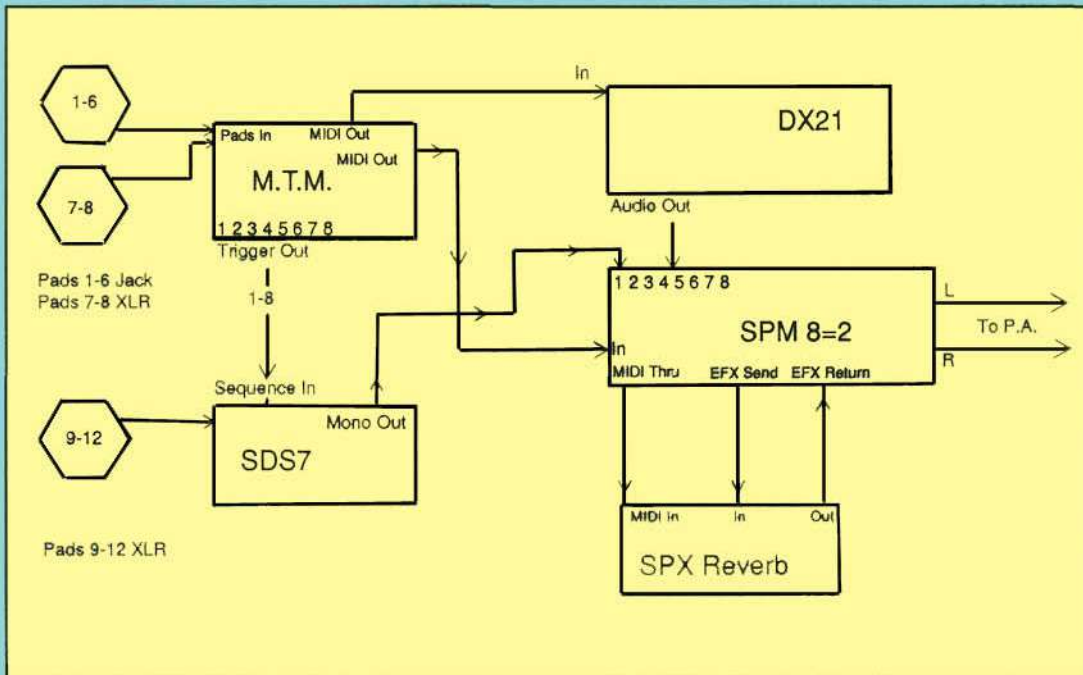

drum could replace the snare and vice versa), which is one of the things you picked up on.

The first album from my band, *Earthworks*, is a complete user's guide to the MTM, which is present on nearly every cut. For example, "Bridge Of Inhibition" features ascending chromatic arpeggios and different repeats on different pads, and "Up North" features two-note chords. The patches storing the required information could be stepped through, forwards or backwards, via a foot pedal. The SPM 8=2 Stereo MIDI Mixer took feeds from the DX21 and the SDS7 and MIDI information from the MTM, allowing further control of mixes so that each patch

Q. I saw an episode of *Rockschool* recently, on which you played a huge electronic kit. Before I saw this show, I had disliked electronic drums, but seeing you changed my mind. When you switched to sound from the bass drum to the snare (and vice versa) and played a five-stroke bass drum beat, I became very interested! Could you please tell me exactly what kit you were using on that show, and describe how the switching of sounds was accomplished?

Zec Herman
Brooklyn NY

A. The drumset was essentially a 12-pad Simmons kit centered around the SDS7 unit, which made the actual drum sounds, and the MTM interface unit, which trans-

lated the drum triggers into MIDI code. Once converted into MIDI language, the drum hits could be passed on to a synthesizer—in this case a Yamaha DX21, and turned into notes or chords.

Pads 1 through 7 went to the 8-channel MTM. (The snare had two outs: pad and rim.) Pads 9 to 12 went direct to the SDS7, and therefore could play only SDS7 sounds. In any one of the MTM's 99 patches, the incoming triggers could either be sent direct to the SDS7 or to the synthesizer, or could give me a combination of both. The MTM could also add such effects as compression or expansion of the pad dynamic range, repeat echos, slapback echos, arpeggios, chords, etc. Drums could, of course, be re-routed (for example, the bass

came up with the right blend of synth-to-drums-to-effects. Each piece of music may have had two or three MTM patches to step through, giving different chords/drums/effects/processing. The new *Earthworks* album is essentially the same method of working, but with the infinitely superior SDX replacing my trusty SDS7, which I had from 1984 to 1988.

I see the whole of these drumkits as being one large creative compositional tool—in no way confining one to being a drummer, but rather liberating one to take on a broader role as a hybrid drummer/keyboardist. And with the powerful SDX computer-based system, the whole thing has opened up still further. I'm glad some of the possibilities excited your interest.

TOMMY ALDRIDGE

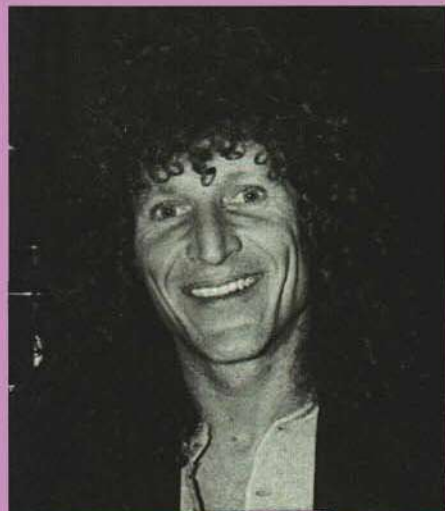

Photo by Mike Jachiles

Q. I would like some information about the drum/cymbal rack you used in the video titled "Give Me All Your Love." I'd like to know what company makes it, and a suggested price.

Peter Rinato
Staten Island NY

A. That rack was custom-made for me by Greg Voelker. He designs and builds stainless steel racks on an individual basis, so each one is unique—and fairly expensive. For more information, you should contact Greg directly at 14016 Dicky, Whittier, California 90605. He can give you a quotation based on a rack tailored to your particular needs.

Q. I saw you live with Whitesnake recently, and I've also been listening to your playing on the Ozzy Osbourne *Tribute* album. You

use a cymbal technique that sounds as though you're playing fast 16th notes with one hand on the ride cymbal, while still managing to hit some crashes, too! Examples would be songs like "Children Of The Grave" and "Mr. Crowley." Could you please tell me how you achieve this?

Mitch Winstead
Marion IL

A. The technique you refer to is achieved by playing 16th notes on the ride cymbal with both hands—not just one—and then reaching over my left hand to play the snare drum backbeat with my right. It's a simple, alternating pattern that many drummers do between their hi-hat and snare. But not very many people do it between the ride cymbal and the snare—which is another reason that I like to do it!

FOR THOSE WHO
CONSIDER THEIR
DRUMMING AN ART...

WELCOME THE
ULTIMATE CANVAS.



custom

SERIES

Z



Years of experience and practice have brought you to this level. The best is no longer a status symbol, it has become a requirement. Custom Z Series, five years of research and development, a lifetime of dreams realized.

All 100% Maple 10 mm square size Toms,
12.5 mm Floor Toms and Bass Drums

provide the player with unequalled
depth, attack, and tonal brilliance.

The Custom Z Series is produced
exclusively in beautiful Champagne
Lacquer over Birds Eye Maple.

For those who consider their
drumming an art . . . welcome the
ultimate canvas.

For more information write to Pearl International, Inc., Dept. Custom Z Info,
P.O. Box 111240, Nashville, TN 37222. Please enclose \$3.00 shipping and handling.

Pearl

The best reason to play drums.

IT'S QUESTIONABLE

Q. I am trying hard to advance my drumming skills, both on the set and rudimentally, and it is paying off beautifully—for my right hand! It seems that my left hand tends to fall further and further behind my right hand's skills. Can you give me any suggestions to improve my left hand's skills (specifically, to use my fingers as I can with my right hand)?

R.T.

Montreal West, Quebec, Canada

A. *Problems with the left hand are common among right-handed drummers. Most experienced players and teachers agree that there is no "quick fix" method for developing the left hand. As with any other under-developed portion of the body, the best way to build up the skill of your left hand is to pay extra attention to it during practice sessions.*

As a suggestion, plan your practicing routine in the following way:

- 1. Stan with a brief workout, as you would normally play, to begin the session. Use both hands, so as to warm them up equally.*
- 2. Work on whatever new material you are studying—again using both hands. This will get your mind alert and further warm up the hands. However, note any weaknesses or imbalances in the left hand's performance versus the right.*
- 3. Using a progressive series of note groupings (single, quarter notes, single 8th notes, 8th-note triplets, and 16th-note quadruplets), exercise the left hand alone for a while. Start slowly, and try to build up speed and evenness at the same time. When the hand becomes obviously fatigued, stop for a moment, and then begin again.*
- 4. Return to your original lesson, and use both hands again. This gives the left hand a bit of a break, and keeps your concentration up.*
- 5. Returning only to the left hand, practice some basic patterns, such as triplets, ratamacues, and even paradiddles (using the bass drum as the alternating beat, not the right hand!). Incorporate dynamics and accents, so that the left hand not only develops strength and speed, but also sensitivity and control.*
- 6. When you again reach a point of fatigue—and possibly frustration—with this part of the exercise, go back to using both hands, and just play something that you are comfortable with and enjoy playing. This finishes your workout on an "up" note, and still gives your left hand a further bit of exercise.*

The key is to develop the left hand while simultaneously developing the overall ability to play with both hands. You cannot ignore your general progress in order to play "catch-up" with the left hand.

Q. Les DeMerle has written two books that I would like to buy: *Jazz-Rock Fusion One* and *Jazz-Rock Fusion Two*. Can you provide me with an address to contact regarding these books?

M.H.

Las Vegas NV

A. *Les's books are published by the Long Island Drum Center, and are distributed by Hal Leonard Publications, P.O. Box 13819, Milwaukee WI 53213.*

Q. I recently purchased an old 4" deep Ludwig wood snare drum. None of the original hardware was present. Inside the drum, the Ludwig & Ludwig crest is burned into the wood. The wood on the drum looks like three-ply, with tuning collars on top and bottom. I was wondering if Ludwig might still have some of the old lug casings, strainers, and throw-off mechanisms around. I've been restoring old Ludwig kits for a few years, and this is the first such snare that I have come across.

J.B.

Ottawa, Canada

A. *According to William F. Ludwig, jr.: "The Ludwig company cannot retain parts for over 25 years. As new models come into production, the company gradually phases out production of older models until all parts are used up. We would have to see this shell*

to ascertain if any parts are still available. If you would care to send Modern Drummer a photo of the shell, we'll be happy to look into it for you."

Q. In almost every one of your magazines, interviewed drummers remind us how important it is to be able to play good time. As yet, no one has revealed any of the techniques they use in trying to keep time—especially when playing drum fills. Yet I'm sure that different drummers have their own special ways of keeping a "constant" tempo. (I am, of course, assuming that no click tracks, metronomes, or sequencers are being used.)

While I'm fairly decent at keeping good time when playing grooves or just "laying it down," I tend to speed up going into fills. In fact, most of my fills sound rushed (when I hear myself on tape). I'm just not taking my time. I make it a point to be as relaxed as possible while I'm playing, but I just can't seem to overcome this problem. Can you help me?

P.S.

St. Augustine, Trinidad & Tobago, West Indies

A. *As you have already surmised, relaxation is a big part of keeping your fills in consistent time. Anticipating fills, and feeling a bit of anxiety about them, can cause a drummer to rush. Excitement about "trying a new lick" can also cause one to accelerate the time during a fill. Relaxing and approaching the fill with confidence rather than trepidation or elation generally helps a drummer to "settle down" and keep the time solid through the fill.*

A technique well-known to big band drummers—who are responsible not only for playing fills that "set up" horn passages but also for keeping a very large group of musicians together at all times—is keeping the bass drum going through the fill. It sounds obvious and simple, but it's surprising how many drummers abandon the fundamental beat of the bass drum when concentrating on playing something fancy "on top." Try to incorporate the bass drum into the fill melodically, so that the fill is both musically interesting and rhythmically anchored.

Another technique that works well is to keep one's fills simple and open. Busy fills tend to accelerate, because a drummer has to work harder and play faster to complete them. Fills with lots of open space can sound dynamic and powerful, yet will rarely cause a deviation in tempo, because they are easier and more comfortable for a drummer to play.

Q. I am currently in college, and have no place to set up and practice my drums. The school has no facilities, and instruments are not permitted in my apartment building. I was thinking of renting storage space at a commercial facility and setting up my drums in there. My question is, will the extreme weather conditions in my area (Pennsylvania) damage any of the drums, hardware, or cymbals? There is no heat or insulation in the building, nor any windows. The temperature could range from 60 degrees to minus 15 degrees. Would warmth during the day and extreme cold at night affect the drums more than a constant cold temperature? And is there anything I could do to help protect them from these types of conditions? I plan on using a portable heater when I practice in the winter, but it would not be permitted for constant heat.

C.K.

Berwick PA

A. *The situation you describe is one that many drummers have to face. Your potential solution is a good one, but you are wise to consider the temperature variances that the drums would have to endure. The cymbals and hardware should not be at much risk, assuming that both are in good condition to begin with (especially the chrome plating on the hardware). Simply keeping the cymbals in a bag and wiping the hardware down when you first come in to practice should deter any potential rust or tarnish. A very light coat of WD-40 or other lightweight machine oil can also protect metal parts exposed to dampness. (The dampness that you should be*

Continued on page 88

DRUM WORKSHOP PEDALS & HARDWARE

DEDICATED DRUM HARDWARE

Since we first opened for business almost 20 years ago, Drum Workshop has been dedicated to developing American-made products that are progressive yet practical. That dedication has resulted in many innovative products such as the Chain & Sprocket Pedal, the Double Pedal, the Turbo Hi-hat, the Remote Hi-hat, the EP1 and the Turbo "E"; products made with the highest quality materials and workmanship so that drummers can play more creatively, comfortably and confidently. Today, our commitment to advancing the drum hardware state-of-the-art continues with the introduction of our Control Cymbal Stand and Snare Drum Stand.

To appreciate the importance, influence and success of DW's drum hardware innovations I invite you compare them to other manufacturers' imitations. Once you do, because you're just as dedicated to doing your job as we are to doing ours, I know you'll want to join the many top drumming professionals who rely on nothing less than the quality and originality of Drum Workshop Pedals and Hardware.



Don Lombardi, president
Drum Workshop, Inc.



For a copy of our all new catalog, send \$3 for postage and handling along with name and address.

DRUM WORKSHOP, INC., 2697 LAVERY COURT UNIT 16, NEWBURY PARK, CA 91320, 805-499-6863 FAX 805-498-7392

D E



Photo by Rick Malkin

C H A M

N N I S

At the 1988 Free Jazz Festival in Sao Paulo, Brazil, Dennis Chambers works out on drums behind saxman Michael Brecker, and a crowd of drummers has gathered backstage to check out his awesome barrage on the skins. Alex Acuna, the Yellowjackets' William Kennedy, Courtney Pine's Mark Mondesir, and Claudio Infante, drummer with Leo Candelman's group, are ignoring their road managers' pleas to board the bus, so they can stay to hear Chambers.

Welcome to the Land of the Undeniable Groove, the rhythmic playground of Dennis Chambers, where there is no such thing as a backbeat too fat, a syncopation too offbeat, a time too complex, or a tempo too fast. The grooves connect solidly, from no matter which direction they come.

After growing up in the Baltimore area, where he started gigging before he entered junior high, Chambers was asked to join the Parliament-Funkadelic brigade when barely out of his teens. Working with the likes of George Clinton, Bootsy Collins, Bernie Worrell, and Gary Shider for the better part of a decade has put a rock-solid knowledge of the groove in Chambers. And the adventurous nature of their music compelled him to learn some dazzling, flashy playing, too.

There were many drum-

mers in the P-Funk caravan, so it was difficult for Chambers to distinguish himself on the group's records. But in the live situation he excelled. Funkadelic manager Bruce Peterson recalls the "band meetings" after Chambers began opening the P-Funk shows with the Brides of Funkenstein. Soon, Dennis was also playing the Bootsy Collins and Funkadelic sets. "He was so good, it was threatening. We had to kick him upstairs," Peterson laughs.

In 1985, after the Funkadelic crew had wound down its touring schedule, Lenny White recommended Dennis to the members of the fusion group Special EFX, who brought him on for two albums, *Slice Of Life* and *Mystique*. Chambers then got a gig with guitarist John Scofield in late 1986. Scofield has high praise for Chambers. "As a drummer, Dennis is completely individual," he says. "He treats music loosely, and is equally confident playing jazz/rock or funk. He's absolutely one of the best instrumentalists I've ever worked with, and that's made it easier for me to play. Dennis has 'the groove of death.'"

It was a good time to get onboard with Scofield. The guitarist had just spent several years with Miles Davis, and his music was opening

up more than ever. Enter a drummer with a propensity for putting the backbeat where it's least expected, for using the left hand in roles traditionally held for the right, and for putting both feet to work on the bass drum, stirring things up ever further. Searching for a more interesting sound, he transposes licks onto different hands, and his legs pump like Bo Jackson's on an off-tackle play. The sensitivity of his playing is in evidence on Scofield instrumentals like "Thanks Again," with light-but-crisp cymbal splashing and floating snare work that marches in its own time.

Chambers' first album with Scofield was a singing jazz-rock blend titled *Blue Matter*, followed by the highly rated *Loud Jazz*. The many fans of this group who saw their blistering live shows (and those who didn't) will be happy to hear the unit's third release, *Pick Hits*, a live performance from Japan. Some drummers who cross over fear getting labeled in one area or another. Chambers is an exception: He plays funk, fusion, rock, and jazz with equal conviction. Chambers does not keep his light under a bushel. On *Pick Hits* he's

splitting his body in two at times, the top half in overdrive while the bottom sits heavy on the groove, or the top half stinging half-time accents while he gallops full-throttle on the double kick pedal.

When Mike Brecker's drummer, Adam Nussbaum, stayed home awaiting the birth of his first child last summer, Brecker asked Chambers to fill in for two weeks of live shows in Brazil. By the end of that tour, the drummer's bebop chops were back at a high level. During one passage, he cracked off a fast single-stroke roll in the middle of one of Brecker's phrases, catapulting the sax player into a totally different direction, even getting his double bass drums involved at the climax of the solo, cross-sticking his cymbals during the fills. Brecker later said, "I enjoyed playing with Dennis immensely. He's a well-rounded musician, and a very quick study. He's dedicated, and just a great drummer in every way. He's very powerful, yet musical at the same time."

B E R S

by Robin Tolleson

RT: What music did you hear while growing up in Baltimore?

DC: When I started playing drums there was a lot of funk and bebop in Baltimore. It was nothing to see Miles Davis and those guys back then, even though it's a different scene now.

RT: Was there anything in particular that you heard that made you want to get into music?

DC: Yeah, James Brown. Also, my mother, Audrey Chambers, was a Motown singer. She had stopped singing when I was two, but

to make noise, and then trying to develop that noise into something. That's what drove her nuts. She would put on a lot of jazz records. The first thing that I remember hearing was "Take Five" by Dave Brubeck, with Joe Morello. That really caught my ear. It sounded so simple, and then all of a sudden here comes this solo, and this guy's playing all this stuff. I didn't know what the hell it was, but it just made sense. So I would try to emulate it, and from there I just went right into listening to Art Blakey, Max Roach,

bands. Top-40 at that time was completely different from Top-40 today. It covered James Brown to big band.

RT: And you were playing that stuff at six?

DC: Yeah, but I didn't have the full understanding of it. All I did was try to emulate it. But I did a pretty good job of swinging the band.

RT: Do you think there was something natural there?

DC: Yeah, a lot of people say it was a God-given talent. I was always practicing. I would get up in the summertime and hop right

on the drumkit until about sundown. My mother would make me take a lunch break, and then I was always playing, always banging. And then if I wasn't doing that, I would go out on a big Harley-Davidson motorcycle. I'd listen to the rhythms that the motor would make and I'd try to emulate what I heard. I didn't know about paradiddles or single strokes and double strokes and all that until I went to senior high school. Someone said to play a Paradiddle, and I was like, "What?" They showed me what it was, and I went,

"Oh yeah, that." I saw other people do it before, and I would emulate it, but I didn't know it was a paradiddle. They didn't tell me what they were going through, and I was just sitting behind them listening, closing my eyes and trying to remember it. Then I'd try to play the same pattern.

RT: So did you take any lessons when you were young?

DC: No. I just listened.

RT: Did you ever join a school band?

DC: I joined in senior high school. The music teacher had told me to check out

John Pratt's *26 Standard American Drum Rudiments*. I still have that book.

RT: Would you recommend studying rudiments first when you begin learning to play?

DC: If you're going to be serious about it, you should understand certain things like long-stroke rolls, double-stroke rolls, fives, flams, drags—stuff like that. Some of the other ones are just exercise—something to get your wrists loose. You can't use a lot of it on the drumkit. But I practiced a lot of single-stroke rolls early on, and I started into double-stroke rolls well before high school. My cousin, Gregory Page, played drums, too. From watching him, I got the feeling that the single-stroke rolls and double-stroke rolls were really important to the drums, as far as soloing and stuff. I just practiced singles and doubles and tried to make it sound like one. It's the same thing Tony Williams does in a solo. He goes through a lot of rudiments, but it all sounds like a single-stroke roll. It's weird, but that's what a lot of good drummers back at that time did. They would do all these rudiments and make them sound like one big thing, with real smooth transitions. My cousin could do that, and I would emulate that.

RT: Did you ever have any trouble getting a smooth double-stroke roll down?

DC: No, I was doing that between the ages of six and nine. When I got to high school, the music teacher there, Charles Anderson, had great hands. He couldn't play a drumkit, but you put him on the snare drum and close your eyes, and you'd swear it was Billy Cobham. But I would outlast him. He ran out this method where you go through single-stroke rolls, paradiddles, flams, 5's, 9's, 12's, and he'd have me play it straight down. It's like a bar apiece. You'd be playing some weird shit, and it sounded good. I miss going through that stuff with him. By practicing single-stroke rolls and double-stroke rolls, I was a lot

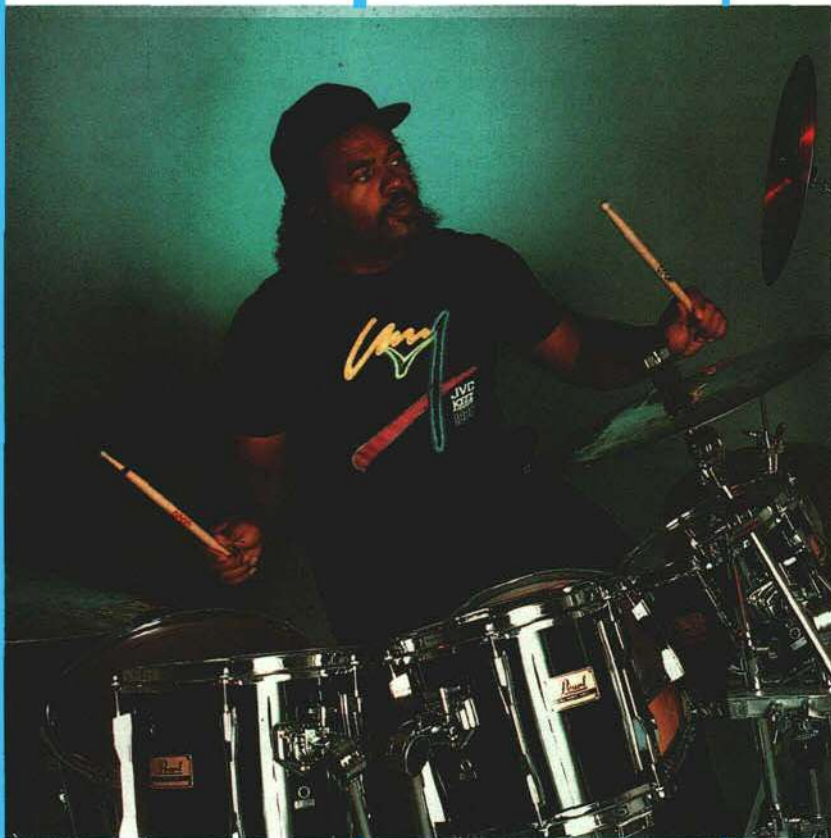

Photo by Ebet Roberts

had formed her own band in the Baltimore/Washington area. I saw her drummer playing, it caught my ear, so I just started picking up knives and forks. I really liked what the drummer was doing; I liked the motions. So I started playing.

RT: Was your mother supportive of you and your music?

DC: Somewhat. She couldn't stand to listen to all that noise going on, with me actually going through the learning process. You don't know what you're doing at that age. You're just banging

Philly Joe Jones, Papa Jo Jones, and Elvin.

RT: You went right to the big time. How old were you when you got a drumset?

DC: I was three and a half. The first kit I got was like one of those little Sears drumkits, but the second one was a small, *real* drumkit that my parents picked up from a used musical instrument store. I had those drums for at least six years; I would play nightclubs with them. I started playing nightclubs at the age of six.

RT: With who?

DC: It was with Top-40

stronger than he was before I got to high school. We would make bets who could last the longest playing double-stroke rolls real fast, and I would always win. He would always challenge me to do something.

I was lucky that he saw what I was about, and took an interest. But I think it was more of a challenge for him; he wanted to see if he still could do certain things. We were both learning from it.

I use to have some really killin' single-stroke and double-stroke roll chops when I was younger, even though lately I haven't really been practicing. I use to be able to make single-stroke rolls sound like double-stroke rolls, like a buzz roll. That's the way I had it at one time. When I joined P-Funk, I had a thing for practicing, but I had to stop, because P-Funk's music and what I was about at that time were just like total opposites. But in order to keep the gig—and I *wanted* to do the gig—I had to stop practicing. So I've gotten into the habit of not practicing. And I *need* the practice now, because I'm on the other side of the fence where I can do a lot more, and express myself a lot more. There's a lot of things I'm thinking about, and I know I just can't pull them off, because I'm not that strong anymore.

RT: You mentioned James Brown earlier. Was his drummer influential, or just his music in general?

DC: It was more his music. It was the drummers, too though. Billy Cobham played with James Brown on a lot of sessions. When I was with Parliament-Funkadelic, I met Maceo Parker, Fred Wesley, and Bootsy Collins, who all played a part in James Brown's music. They told me that they originally hired Billy Cobham as a percussionist. They had no idea who he was or what he was about at that time. Their drummer didn't make the

session, and he wound up playing drums. They still had no idea what he could really do until after Mahavishnu had come about. They said, "Oh, that's the same guy." It kind of freaked them out.

RT: How did your gig with P-Funk come about?

DC: A bass player friend of mine, Rodney "Skeet" Curtis, loved the way I played, and I loved the way he played. We played together with Uncle Remus and a group from Baltimore called Hot Ice, and he wound up getting a gig with P-Funk.

body in that band loved the way I played. I joined the Brides of Funkenstein in 1978, in 1979 I was playing with the Brides and doing a set with P-Funk, and from 1980 to '85 I was with P-Funk.

RT: That must have been pretty demanding, playing the two sets.

DC: Yeah, and I had to play *three* sets some nights, because I used to do things with Bootsy, too. It was a challenge to play all those hours.

RT: But they didn't want to

happening.

RT: What did you record with them during that time?

DC: That's a hard question, because we did so many albums and sessions. I know I'm on *Glory Hallastoopid* and *Knee Deep*, and the *Uncle Jam Wants You* album.

RT: Is that you playing on "One Nation Under A Groove"?

DC: No, that's Bootsy Collins, surprisingly enough. Bootsy plays drums, too. There's a lot of drummers in that band. As far as live stuff,

DENNIS CHAMBERS' SETUP

Drumset: Pearl *MLX* series in custom yellow finish.

Cymbals: Zildjian.

- A. 6 1/2 x 14 aluminum snare
- B. 8 x 8 rack tom
- C. 8 x 10 rack tom
- D. 8 x 12 rack tom
- E. 9 x 13 rack tom
- F. 14 x 14 floor tom
- G. 16 x 16 floor tom
- H. 16 x 18 floor tom
- I. 14 x 22 bass drum

- 1. 13" K/Z combination hi-hats or 14" *Brilliant Quick Beat* hi-hats
- 2. 16" K *Brilliant* dark crash
- 3. 18" K *Brilliant* dark crash
- 4. 12" K splash
- 5. 22" *Brilliant Earth* ride
- 6. 17" K *Brilliant* dark crash
- 7. 17" K *Brilliant China Boy* low or 16" *Brilliant China Boy* high with six rivets (inverted)

Hardware: Pearl *H-900* hi-hat stand, and a DW 5002 double *Dedal*. All drums and cymbals mounted on a Pearl rack system.

Heads: Remo coated *Ambassador* on snare batter side, *Ambassador* snare head below. Remo *Pinstripes* on tops of all toms, Remo *Diplomats* below. Remo *Pinstripe* on bass drum batter side, Pearl logo head with hole cut on front.

Sticks: Regal 5A wood tip or 8A wood tip.

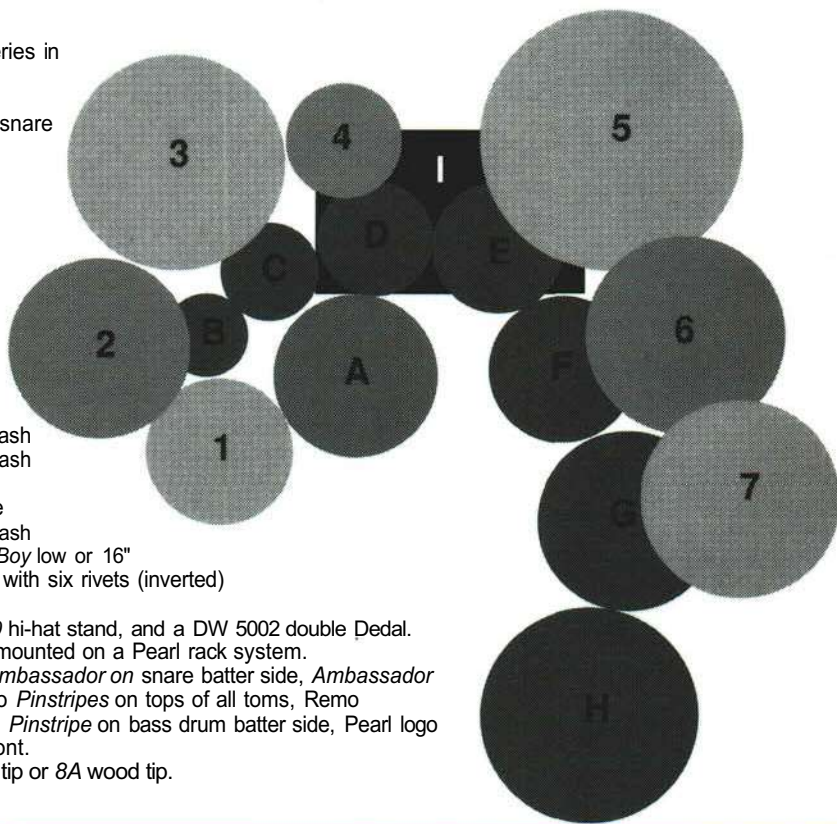

They were going through drummers, and he tried to get me in with the band. But every time he tried, something happened with the drum chair. One time he had talked George Clinton into hiring me, and all of a sudden one of James Brown's drummers named Nate came in, and that prolonged my wait. When I finally got there, I started playing with the Brides of Funkenstein [a P-Funk off-shoot]. I wound up going over to P-Funk, because George and every-

hear any of your jazz playing.

DC: No. They loved it at soundcheck; they thought it was phenomenal. But the gig was 2 and 4 on the snare drum, and keeping the basic funk. In '83 it all switched up. People were calling that band the black Frank Zappa band. We used to do a lot of wild and crazy things with horn accents—playing three over four, or playing 16ths while we were playing the four. There were some interesting musical things

they used to play the Budweiser Fest across the country, which freaked a lot of people out, because I would play timbales, cowbell, and cymbal with my left hand, and play the groove on the complete drumset with my right. I had two things going on at all times.

RT: I saw Ndugu Chancier do that kind of thing when he was with Santana.

DC: Right, the same thing. I think that's where I got the idea from. I saw Ndugu on



"Finding the groove is simple. Listen to what the bass player's doing."

tour with Santana back in '76 or '77, and I figured, "Well, that's interesting." I tried it, and the next thing I know, I'm playing timbales with the left hand with P-Funk.

RT: How do you go about finding the groove in a song?

DC: Finding the groove is simple. Listen to what the bass player's doing. If the bass player has some sort of pattern, where the beats fall in certain places, then you think about playing beats that fit his thing to make a pocket. If he's playing 16ths, either you can play 16ths with him, which will sound busy, or you can play 8ths. You can do things like placing the backbeat on 1 and 3 instead of 2 and 4. It all depends on what's going on at the time, but I basically listen to what the bass player's doing. With John Scofield there are four things to pay attention to—guitar, bass, keyboards, and drums. So I'm listening to the bass player plucking and popping these rhythms, as well as playing off of John Scofield—or whoever is soloing at the time. But you have to make it feel good. In order to make it feel good, you should start off simple, and then you can build into some crazy, frantic thing. But you still have to get the feeling that that groove is still there somewhere. People always ask me about all that crazy stuff that I play, like

playing against the music. I used to practice with a click track or drum machine on a 2 and 4 groove, and then play upside the thing, around the beat, or through the beat—anything and everything but *with* the beat.

RT: You have to be able to keep the beat in your mind, even though you're soloing.

DC: You have to know where you are, yeah. Make it sound like music, but like you're playing with a drum machine. Make it to where people could actually snap their fingers and not get off track with the beat.

RT: When you play on 1 and 3 instead of 2 and 4, the problem could arise that your band might think you're on 2 and 4.

DC: In a situation like that you have to get a bass player to understand, whatever you're doing, *not* to follow you. Gary Grainger and I have a perfect relationship with that. Gary knows not to follow me when I'm doing little crazy things. He just lays the pocket down, just keeps what he's playing pumping out, and then I'll play around it. John Scofield's band is the first where we ever played together, but growing up in Baltimore, we'd always see each other playing clubs. I've sat in with him in clubs, and he's sat in with me, so we sort of had an understanding of each other's playing. I always liked the way he played, so I listened to him and understood what made him tick. Now he's gotten more outrageous with his rhythms, where I don't know *who's* playing drums, me or him. He's really worked out some crazy percussive stuff. When a lot of other bass players do percussive thumb things, it sounds busy, and when they're playing with other musicians, it gets in the way of the music. But Gary doesn't get in the way of the music, it grooves. He's mastered that.

RT: When he's doing his outrageous stuff, do you have to lay back a little more in the pocket?

DC: At first I have to lay back because I don't know what patterns he's going to be

doing. I'll sit back and play the groove, and maybe four or five bars into it I'll figure it out. Then I'll go, "Oh yeah, okay," and play against what he did. That's what makes that John Scofield band happen. Whoever's playing whatever, Gary and I will listen, give it four, eight, or sixteen bars, and once we make sure we know what it is, we'll play against whatever develops, but somehow making it feel like it still fits. For example, playing a feel of 2 and 6 is a weird combination, but it works—if you master it and get it down where one doesn't get in the way of the other. The perfect example of that type of thing is Bill Bruford, like the *One Of A Kind* album. When you listen to it, you feel that the stuff is so simple. But it's just where he places backbeats. You're counting four, but it sounds like there's more to it than four. It's just where he places the backbeat, and he turns the beat around. He'll play over the bar line, playing a real crazy thing, but it's real simple. It's not like he's playing 32nds; it's just 8ths or 16ths. It's all in simple four. He just mastered the whole idea of dismantling or disfiguring the beat. It's all displacement of the beat.

RT: Is it possible to get a good groove if all the band members aren't right on top of their parts?

DC: Yeah, well that's the drummer's job anyway—trying to make it work. You can play with a rhythm section that doesn't have too much experience, and make them sound good, but you don't start off with a band trying to play everything you know from jump. The whole thing is playing music, and sitting back and listening. A lot of drummers these days don't *listen* to the rhythm section. The whole thing about music is that, when you're playing with six people, you have to make it *sound* like you're playing with six people; if you're playing with P-Funk, which was 18 members, you have to make it sound like you're playing with 18 members.

RT: What does that mean, exactly?

LISTENER'S GUIDE

Q. For readers who'd like to listen to albums that most represent your drumming, which ones would you recommend?

Album	Artist	Label/Catalog #
Never Buy Texas From A Cowboy	Brides of Funkenstein	Atlantic SD 19261
The Family Tradition	Don Blackman	Arista GRP 5509
NARD	Bernard Wright	GRP GRP 5011
Pick Hits (Live)	John Scofield	Gramavision D32Y0147
Blue Matter	John Scofield	Gramavision 18-8702-2
Loud Jazz	John Scofield	Gramavision 18-8801-2
America You're Still Number 1	Phillipe Wynn	Sugar Hill SH589
Computer Games	George Clinton	Capitol ST12246
Some Of My Best Jokes Are Friends	George Clinton	Capitol ST12417

Q. Which records have you listened to the most for inspiration?

Album Title	Artist	Drummer	Label/Catalog #
Total Eclipse	Billy Cobham	Billy Cobham	Atlantic SD 18121
Crosswinds	Billy Cobham	Billy Cobham	Atlantic SD 7300-0598
George Duke / Billy Cobham Live	George Duke & Billy Cobham	Billy Cobham	Atlantic SD 18194
Feels Good To Me	Bill Bruford	Bill Bruford	Polygram 2302-075
Ego	Tony Williams	Tony Williams	Polydor (out of print)
Emergency	Tony Williams	Tony Williams	Polydor (out of print)
Believe It	Tony Williams	Tony Williams	Columbia PC 33836
Million Dollar Legs	Tony Williams	Tony Williams	Columbia PC 34263
IOU	Allan Holdsworth	Gary Husband	Polygram CDE-73252
Astral Pirates	Lenny White	Lenny White	Elektra GE-12

DC: It means that when you're playing with whoever's up on that stage, you just don't go off and make it sound like the Dennis Chambers show. You have to give everybody their space, and leave space for nice things to come around—space to breathe. A lot of guys don't give any breathing space. It's not all about blowing, or trying to play all the chops you can; it's about feeling. Scofield's thing is more about feeling now. The records I've done with John have always been recorded live. We all played together in one room, and tried to get it down in one or two takes. If that doesn't work, he'll just keep cancelling the takes until we all get it together. He'll mess up some things, and instead of keeping the rhythm track while he overdubs his thing, he'll do the whole thing over.

RT: Where is the heart of your playing, in your hands or feet?

DC: Both. Whatever I do, I like breaking it up between hands and feet. The stuff that I'm working out with snare drum now, I like to put a bass drum into it. If I'm doing single-stroke rolls, I'll try to do the old Tony Williams

thing of playing the single between the left hand and right foot or the right hand and left foot.

RT: It always sounds good when the bass drum is involved. How did you learn the double bass drum technique?

DC: When I got a double bass drum pedal, like anybody, the first thing I went for was single-stroke rolls with the bass drum and 2 and 4 on the snare—the Billy Cobham thing. After that, the best thing to do is try to work out rudiments; what works for your hands should work for your feet. I've never taken the time to work out rudiments on the bass drum, but I recommend that. If you notice the double bass stuff that I do, I'm always playing time with my hi-hat as well. When I'm playing that little thing with the cross-rhythms, playing with the hands against the feet, the rhythm I'm keeping going on the bass drum is a three-beat triplet, which is two on the right, and one on the left. That allows me to play time with the hi-hat as well.

RT: At the same time you're doing the double bass stuff?

DC: Yes. The one beat that I'm playing with my left foot,

I'm playing the hi-hat along with that beat on the bass drum. So that's serving two purposes—playing time and playing that extra beat on the bass drum. And then I'm playing things against what that bass drum is doing. The bass drum might have a Latin feel, and on top of that I can do single-stroke rolls—speeding them up or slowing them down—or play Latin rhythms that don't have anything to do with the bass drum. It's like playing poly-rhythms on top of the bass drum.

RT: Your left foot is on the hi-hat or bass drum pedal?

DC: It's on both.

RT: What kind of pedal do you have to enable you to do that?

DC: You can do that on any double bass drum pedal. It just depends on where you set your hi-hat. I usually have my bass drum pedal right next to my hi-hat pedal. If you're going to play double bass drums, you may as well get all you can out of it.

RT: Did your talents with your feet come naturally?

DC: I don't work on anything too much. I always have a drumkit set up at my house, but I don't go down and play it or practice a lot anymore. Once you reach a certain plateau in your playing, everything after that just sounds like a routine. You find yourself on gigs playing the same way you practice in your bedroom, which is wrong. And then night after night it's the same thing, because you're so used to sitting there going through the routine. I like to be fresh. You shouldn't have just three or four patterns in your mind all the time to play.

RT: What would you say you learned from playing with P-Funk?

DC: I learned how to play a serious pocket. With that band, I had to play with 12 guys. When I first joined, there were two bass players, four guitar players, four guys in the horn section, two keyboard players, and a percussionist. With P-Funk I learned basically how to play music with a rhythm section, and how to play funk grooves. That's what that band was about. And then from '83 to '85 I sort of got my own feel

Continued on page 52



Photo by Aldo Mauro

Chris Black

When we had finished doing this interview, Chris Blackwell thanked me for not asking the obvious questions. Now, an interviewer doesn't like missing the obvious, because although it might be boring for the interviewee, it might be exactly what the readers would be interested in. So I raised a quizzical eyebrow. "Things like, 'What's it like to be following in John Bonham's footsteps?'" said Chris. "Bonham, Jimmy Page...Doug Boyle and I are always being asked about them. Usually at 3:00 in the morning, by someone on a transatlantic telephone line!"

*Put bluntly like that, the question isn't really a relevant one. Of course, when you've got a band fronted by Robert Plant, the Bonham link is there for all to see; but on the other hand, the Robert Plant Band isn't Led Zeppelin, and it's doubtful whether they are doing what Zeppelin would have been doing had they survived to the present day. You only have to listen to the album *Now And Zen* to realize that Plant has moved on, so simple logic would indicate that the members of his band are not clones of his colleagues from Zeppelin days. A musician can only really be said to be "stepping into someone's shoes" if he is playing the same music in more or less the same way. Playing with the same singer isn't the same thing at all.*

It might seem that I am spending a lot of time discussing a question I didn't ask, but I think it is important

for us to view Chris Blackwell as an individual and creative player. In many ways he is one of the "new breed" of star rock drummers. He is heavily involved in playing his instrument, with all the technique and stamina that it calls for; but he is also heavily involved in keeping abreast of all the new technology, and using it to the best advantage. In the Robert Plant Band he has found the ideal vehicle in which to combine these talents.

Chris has got other talents, too: As a composer he has had success as a writer of jingles and incidental music, which is a facet of his career that he would like to extend. He has appeared rather suddenly in a big-name rock band, and he looks younger than his 31 years, so he might be thought of as having "come from nowhere." In fact, Chris Blackwell has been building up a reputation in the London studios for the past nine years. He's not just a hard rock drummer; before working with Plant, he was in the backing band for Bucks Fizz, an English vocal pop group. The man is versatile.

The lineup of The Robert Plant band is completed by Phil Johnstone on keyboards, Doug Boyle on guitar, and Charlie Jones on bass. If you heard the band, you would think there were many more people there. The answer is, of course, electronics. When you learn what Chris Blackwell and Phil Johnstone actually handle, you might consider that the standard five-piece rock band will never be the same again!

Qualifications

well

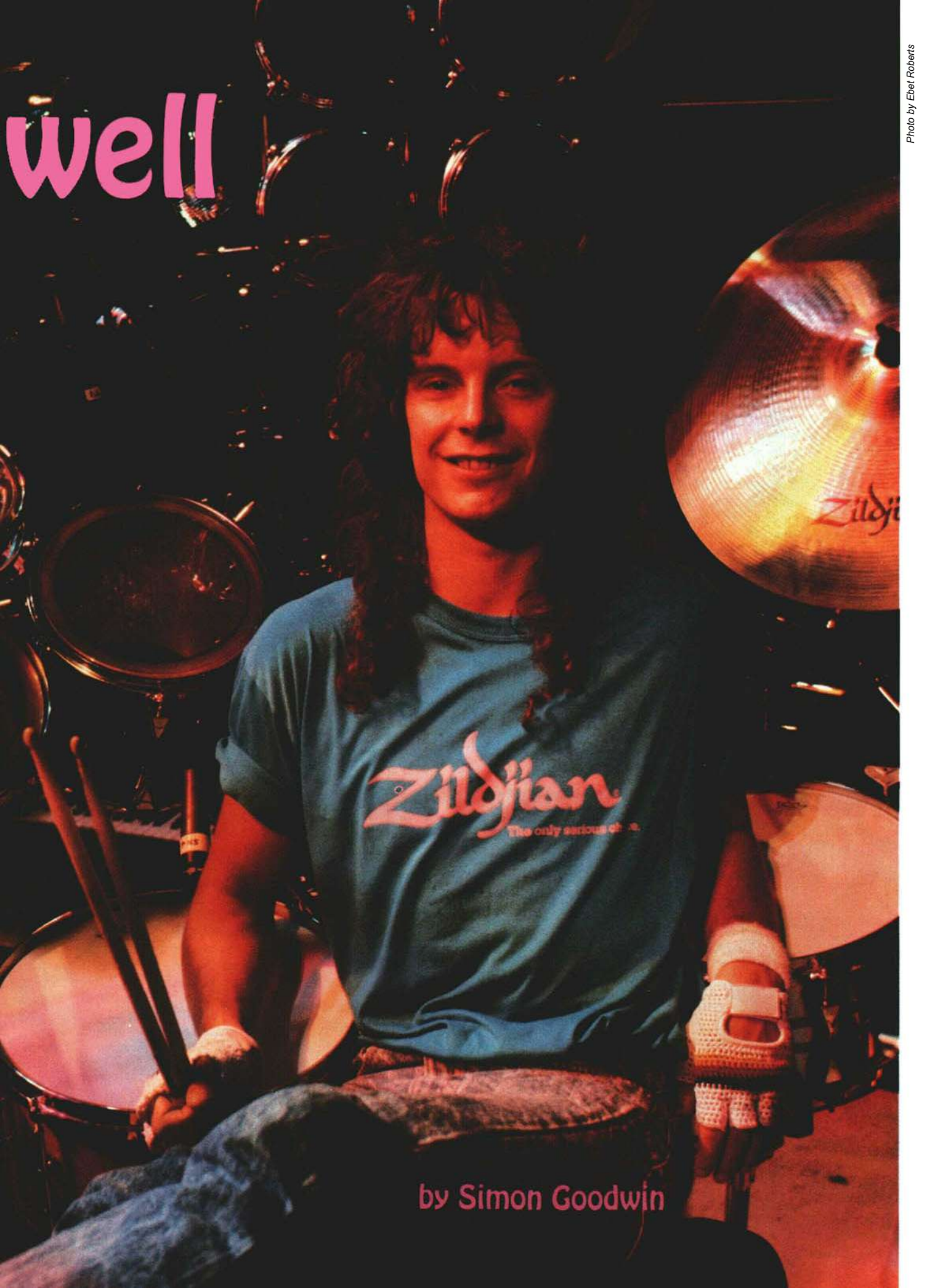

by Simon Goodwin

SG: Could we start by talking about the triggering you do on stage with Robert Plant's band? Apparently it's been misunderstood by people who aren't aware of just how much of the sound you are responsible for.

CB: Yes, a lot of people think that the triggering that I'm doing is being done by the keyboard player. But in addition to my acoustic kit I've got four Roland *PD31* pads, which have four triggers each: There are the three rims and the center of the pad, which can all trigger different samples. The pads are connected to a Roland *PM16*, which converts the information to MIDI and in turn is linked to two Akai *S900* samplers. I have two *S900s* so that Martin Hodgeson, my drumtech, can load one up for the next number while I am using the other one.

We went into the studio and took a lot of stuff off the album—backing vocals, keyboard parts, drum sounds—and we trigger them live on stage. When we are on stage there are female backing vocals, but there are no girls on stage doing them. Now that's *not* on tape; I'm triggering it at specific points. It's great until you miss a cue and hit it maybe half a beat off from where you should have hit it. Because it's a sample, it won't correct itself. When this happens with a long sample of, say, six seconds, you get six seconds worth of backing vocals in the wrong place, and there's nothing you can do about it. [laughs]

In the next part of the tour I'll be doing certain things with three pads, standing up at the front of the stage. It's a departure from playing the kit. All the sounds on these particular songs were sampled sounds on the album, so we figured that we could take it further and move the whole thing out to the front and have me play it from the pads. There are no drum machines. When I first started doing this I didn't want to use drum machines or tapes; I wanted to *play* everything. On two tracks, "Ship Of Fools" and "Big Log," there's a *TR808* drum machine *sound*, which is actually a two-bar looped sample. I feel better about doing that than having a drum machine sitting there ticking away.

SG: Why do you trigger these things? Why not the keyboard player, or even a sound engineer?

CB: Because having a sound engineer doing it would take away from its being musicians actually playing it on stage as a performance. When you see a lot of bands using tapes and sequencers on stage, it isn't a performance anymore. They're just playing along to something. There's no room for spontaneity, because *that's* how it is on the tape or the sequencer and that's how it's got to be. They can't say, "Hey, this middle bit is going really well. Let's extend it, let's have some fun," because the tape won't suddenly add an-

other 16 bars in the middle. If you had a sound engineer out front who was responsible for the triggering, he would have to work to a set routine because he wouldn't be directly involved with what is happening on stage. When Robert turns around and gives us that grin, which means, "Okay, let's go for it," a sound engineer wouldn't see that out front, so he'd be slinging the samples in in the wrong places. As far as Phil Johnstone is concerned, he's doing a lot already. It's something that I've been experimenting with at home, and it seemed logical for me to take it out and perform with it. It's all under our control, and we're not relying on sequencers, tapes, or anybody who isn't on stage.

SG: The concept of having triggered backing vocals seems strange to me for two reasons: First, you can more easily accept this sort of treatment for sounds that are electronically produced in the first place than you can for the human voice. Also, having female backing singers on stage makes a pleasant *visual* change from having to look at a bunch of big hairy rock musicians. No offense meant!

CB: [laughs] Oh yeah, I agree. But this is just an alternative way of doing it. I haven't seen anybody else triggering backing vocals as we do, but I *have* seen people with backing singers on stage *miming* to a tape. That's just for show. If you've got the sounds on tape, you don't need people miming. It's more honest to trigger them, and not have anybody there. When we first talked about doing it this way there were lots of arguments about whether we should or shouldn't. But a lot of the backing vocals have completely different sounds, and there are a *lot* of different parts in there. Also there's the point that Phil, Charlie, and I do a lot of backing vocals as well! We reinforce the sound; it's not as if there's just a sample going off and that's it. To me this is an ideal compromise between playing completely live with no backing singers or playing against a tape. The way kids' ears are tuned in to music these days, everything has to sound the way it does on the record, and if it doesn't they go away thinking that it wasn't a very good gig.

SG: You said that you had been experimenting with the triggering at home. Was it your idea to do it with the band, or did somebody ask you to try it?

CB: I used to do a lot of sessions before I became involved with Robert. A lot of the stuff I'd be called in to do would be things like tom-tom overdubs on a computer drum track. It got to the point where I said, "Why don't I get involved in the other side of it, and do the programming as well?" I didn't feel so bad about it being a machine if I'd programmed it in the first place. So I got an *Octapad*

and various things like that, and started playing things into the computer. Then I tried experimenting with ideas of my own—simple things like not quantizing. With most people that's unheard of; you've got to quantize anything coming off a machine. But I found that if I didn't do that it would sound more like a real drum track. It's a compromise between using a real drummer and using sampled drums. If a real drummer plays sampled drums, it's better than having a producer sitting there tapping away at a keyboard. The technology is there, and it's going to be used, but let's have a drummer using it.

Drummers have been *just* drummers for too long. They sit at the back and thump away, and the only way they can get recognized is by having more drums than anybody else, or if the kit turns 'round or goes upside down, [laughs] I think that another way of doing it is to be quietly confident, knowing that you're doing all this other stuff as well. Maybe people will realize that you're doing it, maybe they won't. But if they say, "He's not only



Photo by Ehet Roberts

CHRIS BLACKWELL'S SETUP

Drumset: Tama *Granstar* in gun metal grey finish.

Cymbals: Zildjian, miked with Zildjian's *ZMC-1* miking system.

- A. 8 x 14 bird's eye maple snare
- B. 3 12 x 13 *Artstar* piccolo snare
- C. four *Octobans*
- D. 10 x 10 rack tom
- E. 6" RotoTom
- F. 11 x 12 rack tom
- G. 13 x 14 rack tom
- H. 16 x 16 floor tom
- I. 16 x 18 floor tom
- J. 20" gong drum
- K. 16 x 22 bass drum

- 1. 13" K hi-hats
- 2. 20" *Rock ride*
- 3. 10" splash
- 4. 16" crash
- 5. 12" splash
- 6. 17" crash

7. 14" K hi-hats (mounted on an *X-Hat*)

8. 20" *China Boy High*

aa. Roland *PD 31* pads

Photo by Ebel Roberts

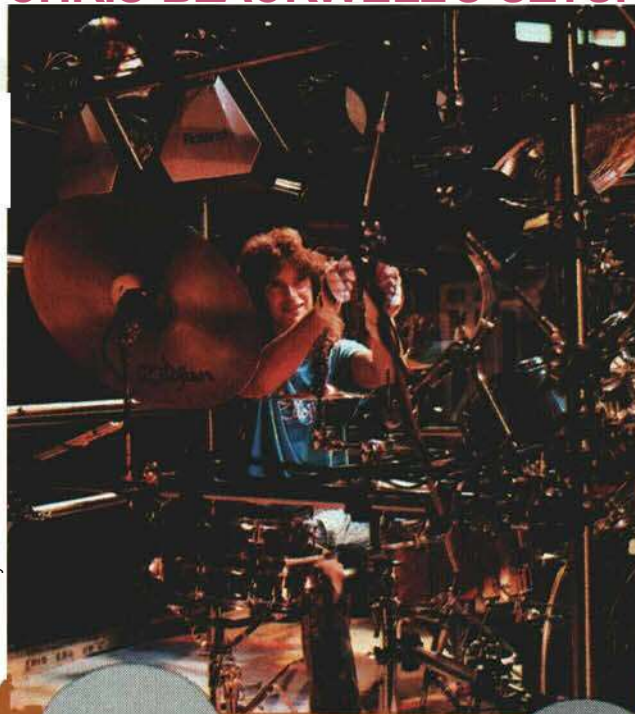

Hardware: All hardware Tama, including a legless hi-hat stand and a strap-drive double pedal (lefty). Everything is mounted on a Tama *Power Tower* rack system.

Heads: Remo *Emperor* on the 8" snare, a Remo *Diplomat* on piccolo snare, Remo *Ambassadors* on all toms, and a clear Remo timpani head on the gong drum. Remo *Pinstripe* on the bass drum batter side, and a Tama logo head with a 12" hole cut in it on the front. The bass drum is heavily padded, and the bass drum beaters are filed-down wood. An extra piece of mylar from an old head is taped to the batter head where the beaters hit. According to Blackwell, "Acoustically the bass drum sounds pretty awful, but when it's miked up, I get all attack and lots of bottom as well."

Sticks: Pro-Mark 747 model.

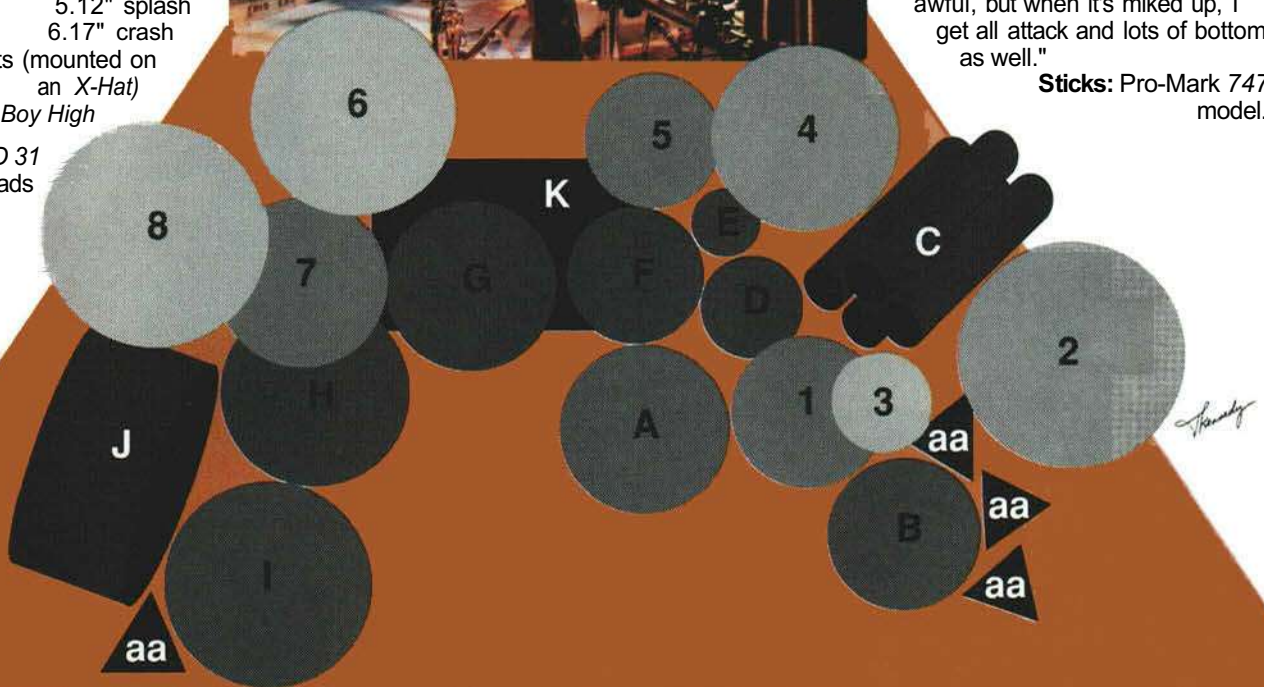

drumming, he's also doing all that *other* stuff," that's great.

SG: Do you ever find that you need to compromise on the actual drumming, in order to have a hand free to do the triggering?

CB: No. That's the whole point of it. A lot of the samples are quite long, like six-second bursts, but I've only got to hit it once. Quite often they fall under a cymbal crash, so I hit a cymbal with one hand and a pad with the other. It isn't difficult, but you just need to think about it a bit more. As well as keeping everything steady and keeping the band together with what you're doing as a drummer, you have to incorporate the extra stuff. It's a challenge and it's fun.

SG: Presumably the patches that you have assigned to the pads are constantly changing, and you have to remember which sound is where from song to song?

CB: Yes. In every number, all the pads are different. The *PM16* has 16 inputs on the back, so you've got access to 16 different triggers at any one time. You can store 64 songs; and then if you need it there's a memory card that gives you a *further* 64. So yes, there is a fair amount to remember. You make a lot of mistakes. They can be quite spectacular mistakes as well! But if you're going to do it, you

might as well do it loudly—"loud and proud and wrong!"

SG: Has this ever happened in a performance?

CB: Oh yeah! The audience wouldn't know, but on stage it's very funny. There's all this stuff going on; Phil does a lot too, he's got four or five samplers. Sometimes there's some hilarious stuff happening, but even people who are with us—management people etc., who are out front—don't realize that there's been a mistake

SG: You said that once one of these samples has been set off in the wrong place, there's nothing you can do about it. It must make it difficult for Robert, if he's got to sing with the wrong notes going on behind him.

CB: Oh yes, it does; but he just laughs about it. Again, the audience doesn't see it, but he turns around and calls us all sorts of names. When something like that happens, the only thing you can do is laugh about it. There's no point in saying, "Damn, that was a terrible mistake," and getting depressed about it. When it happens it's funny, because you're in front of thousands of people and there's this horrendous mistake happening, but you can't stop it.

continued on page 60

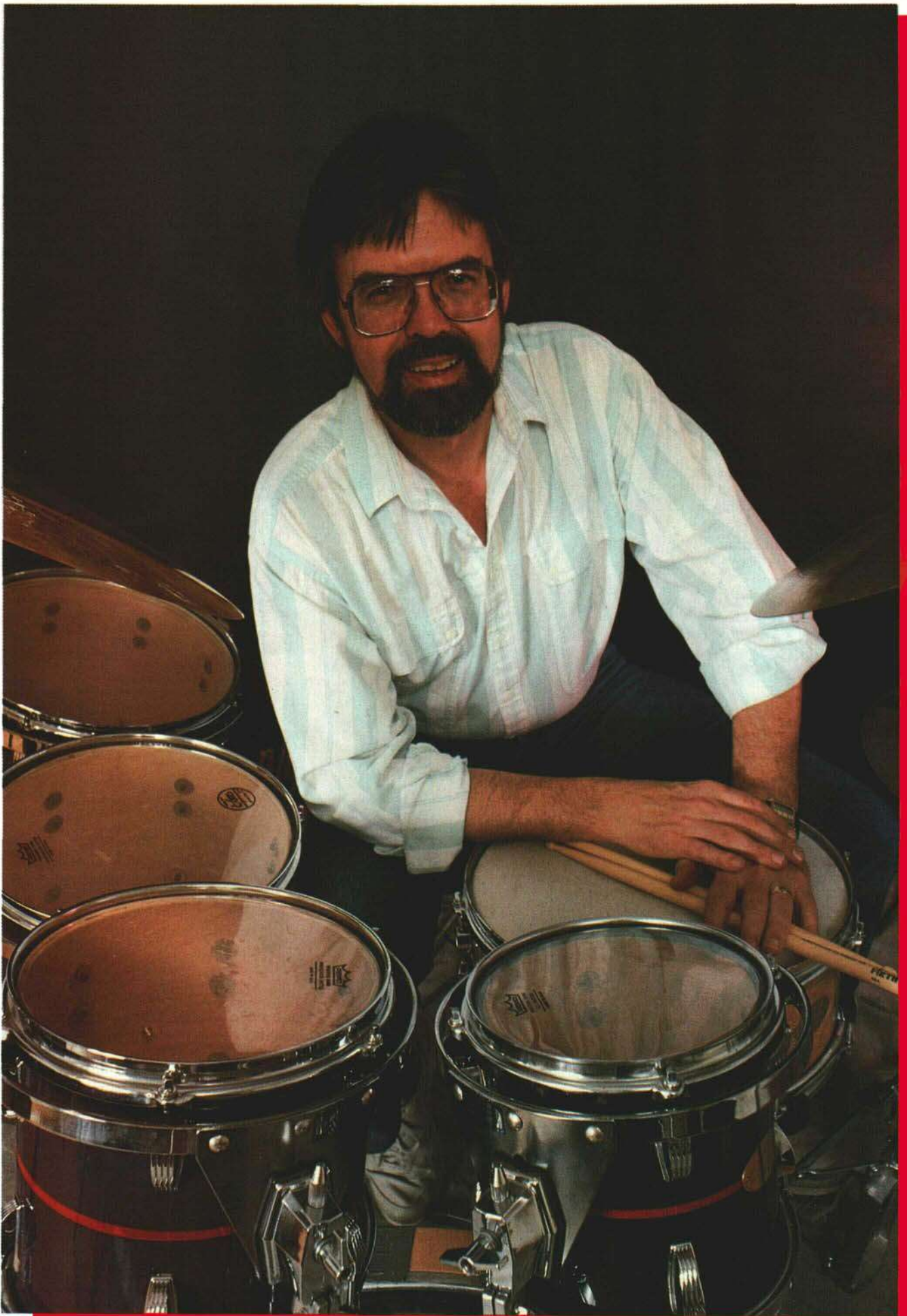
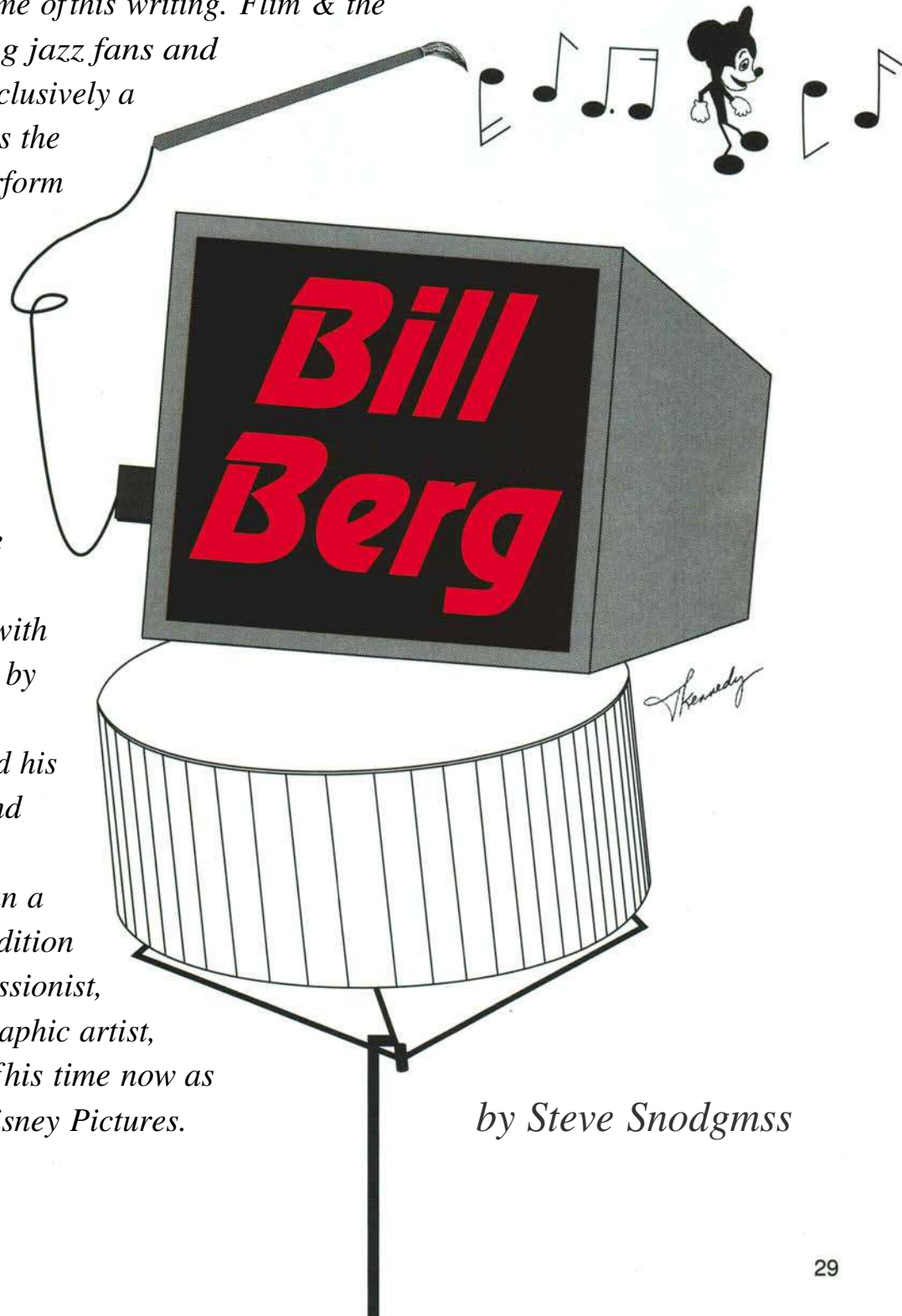

Photo by Jaeger Katos

Bill Berg is a BB. That is, he's one of them. The other is keyboard player Billy Barber, and together with Jimmy "Flim" Johnson on bass and Dick Oatts on reeds, they are the eclectic quartet known as Flim & the BB's. Originally from Minneapolis but now split between coasts, they are one of the premier bands on DMP, the all-digital record label founded around the compact disc medium in 1982 by engineer Tom Jung. All veteran studio musicians, Flim & the BB's began their tradition of live-to-two-track digital recording back in 1978 with an experimental prototype recorder. The resulting LP is now a collector's item, but the group has since released four all-digital CD's, with a fifth on the way at the time of this writing. Flim & the BB's' popularity among jazz fans and audiophiles is almost exclusively a result of these albums, as the members only rarely perform as a group outside the studio.

It was in Chicago after one of those rare concert appearances that I first spoke with drummer Bill Berg long enough to find out more about him and his work with the band. Talking with me backstage, and later by phone from his office in California, Bill discussed his career as a drummer and artist. The word "artist" applies here in more than a musical sense, for in addition to being a veteran percussionist, he is also a dedicated graphic artist, spending a great deal of his time now as an animator for Walt Disney Pictures.



by Steve Snodgmss

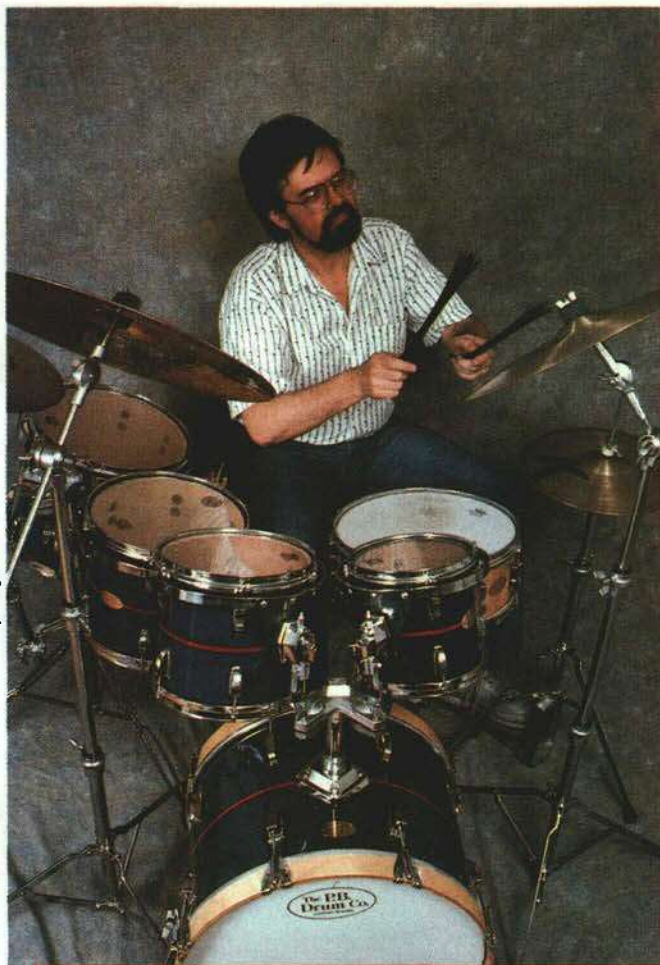

AS I SPOKE WITH BILL

it became clear that his two crafts are not only compatible but also quite complementary.

One of several musical insights he has developed from the principles of graphic design is a sense of balance—of loud and soft, busy and simple, aggressive and laid back. This balance has become a trademark of his playing, and it's one of the reasons his work with the dynamic music of Flim & the BB's feels so right. Another reason is Bill's extensive musical background; a hunger for diversity as a young drummer led him to play in a variety of musical styles and settings that many of his local colleagues left unexplored. A stint as a Navy musician helped round out his playing even further, but it is his finesse—gained from countless hours in the Minneapolis area recording studios—that one can sense and appreciate most when listening to Bill's performances with the BB's. Live-to-two-track digital recording demands virtual perfection from musicians once the tape rolls, and often for Bill, a great deal of agility too; without the luxury of overdubs, every desired percussion part must be played in real time. It's a challenge he claims to enjoy, however.

Bill Berg's drumming with Flim & the BB's is always sensitive and always interesting—he seems to have an inexhaustible rhythmic creativity—but perhaps more than

anything else, it's just plain fun. The group is anything but shy about taking advantage of the compact disc format's incredible dynamic range, and when you hear Bill leap from a pianissimo hi-hat groove into a fortissimo flurry of sound, and then back again as if nothing happened, you can't help but smile. If you listen closely, you can almost hear Bill smiling back.

SS: Flim & the BB's has really taken off with the popular digital CD releases, but you guys have a long history of playing together. Tell me about the band's beginnings in Minnesota.

BB: It began when I heard about Billy Barber and Jim Johnson playing in a group called Debb Johnson. I went to see them in concert and I was floored; I said to myself, "I've got to play with these guys." One thing led to another. Billy had an apartment in South Minneapolis. We jammed over there one time, and it was like magic. About that same time Dick Oatts and I played a Ralph Marteiiri big band gig in Madison, so that's how I met Dick.

The BB's started in the mid '70s and played clubs, and we'd feature guys like Dick Oatts or other local horn players. I left for California, and later on the band did a direct-to-disc project that Tom Jung, the engineer, was associated with. And then the early '80s came along and he said, "Hey, you guys want to do something else? There's this CD medium happening." I wouldn't say we're super-popular, but we're growing, and I think the disc phenomenon has helped us. I think our music has lasted and means something to people, and it's just fun to play.

SS: You did a lot of studio jingle work in Minnesota, didn't you?

BB: Right, a lot of local TV and radio commercials. There are industrial shows for big clients like 3M and Winnebago, so sometimes we'd do industrial slide show tracks for those. They would be a little more lengthy. So I did a lot of commercial work, and I ended up doing a lot of local and regional album projects—gospel, country, folk, and rock. And then I played with a couple of local bands other than the BB's that were trying to write original jazz/rock

kinds of music.

SS: I would think that the demanding nature of jingle work would be good preparation for the variety in the BB's music and the "one-take" approach to recording.

BB: Yep. One of the first big sessions I did was with a 30-piece live orchestra, for one of the snowmobile makers. I had to sight-read it, get the groove down, sync up with the click, and that kind of thing. Luckily, I had a lot of experience as a kid, playing polka music, country, and traditional jazz—a little of everything. It gave me the background to go in and play a country tune, whereas some of the strictly jazz players in town weren't quite as adaptable.

SS: So you had the advantage of versatility early on.

BB: I had a lot of versatility just because I was very hungry to play many kinds of music, just to round myself out as a player.

SS: You later recorded with Cat Stevens, Leo Kottke; and Bob Dylan.

BB: The first "big" project I did was my first Leo Kottke album in about 1973, called *Ice Water*. That was his first album in a long time with a rhythm section, because he usually plays solo. Back in those days, me and a good friend of mine, Billy Peterson—an electric and acoustic bass player in Minnesota—were kind of the in-house rhythm section at the Sound 80 studio. He and I, and then Flim and I, were part of two different rhythm sections that sometimes worked there with Billy Barber. Leo was working on an album and wanted to try out some new guys, and he called Billy Peterson and me in to overdub a country tune. We played it, he was really excited, and we finished the rest of the album with him. We did five or six other tracks with drums and electric bass and had a wonderful time working with him. He's a real fun guy to play with. I did three more projects with Leo after that, all of them just as fun as the one before.

SS: How did the Bob Dylan gig come about?

BB: I was set to move to California, and I got a call from his office in Minneapolis asking, "Can you make a session tonight? Bob Dylan would like to use you." I just kind of fell on the floor! I had heard he was doing a record, but I thought, "Well, maybe it's a demo thing or he just wants to play with some guys in town and put it on tape."

It turned out that he had started recording in New York with Eric Weisberg & Deliverance. He wasn't real happy about the end results of that, and his brother, who is a friend of mine from Minneapolis, suggested us. We ended up doing the remainder of the album in two or three nights, and we redid some things. So I ended up being on the *Blood On The Tracks* album in 1975.

SS: Tell me about the Cat Stevens record.

BB: When I moved to California I first lived in L.A., but then I decided to move to the Monterey peninsula. My wife was pregnant, and we wanted to get away from L.A.—the hustle and bustle and smog and all that. So we lived there for a while, and I bumped into John Mark of the Mark Almond Band. We had known Cat Stevens' guitar player,

Bill Berg's drumming with Flim & the BB's is as diverse as the group's eclectic music, its improvisational complexity often eluding transcriptional analysis. The examples captured here are but a small sampling of the rich percussive creativity to be found on the BB's' five albums.

This first example shows two simple grooves that Bill plays under the melody of the tune "Tricycle," from the album of the same name (DMP CD-443). He subtly switches between these mirror-image patterns and other variations to a hi-hat accompaniment resembling a delicate tap dance.

MUSIC KEY

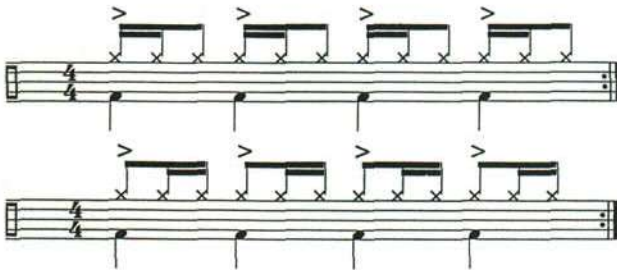

This next beat is a driving, paradiddle-derived solo pattern that sets the mood for the tune "Thunder And Birdies," also from *Tricycle*.



This next pattern, from the album *Big Notes* (DMP CD-454), illustrates Bill's ability to get maximum effect from a minimum number of notes. The out-of-phase backbeat idea drives "Boogie Palace" from start to finish, with only a few short breaks and a brief bebop section during a sax solo.

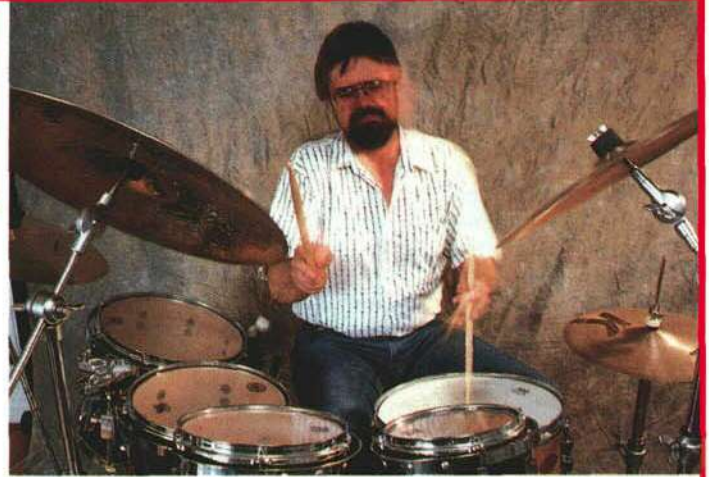
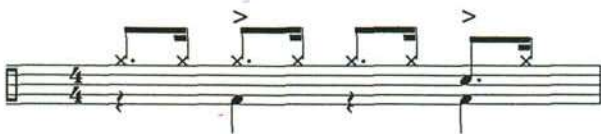
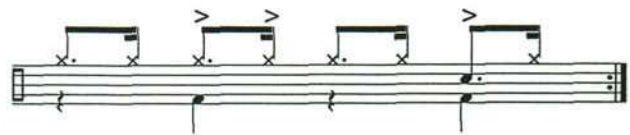

Photo by Jaeger Kotos



The rhythm shown here is the basis for the melody in "Five On The Floor," one of Bill's compositions from *The Further Adventures Of Flim & the BB's* (DMP CD-462).



This pipe-and-drum military feel is established at the start of the tune "Ireland," from *The Further Adventures Of Flim & the BB's*. A heavy digital delay is added to the figure, enhancing the marching-band effect.



—Steve Snodgrass

and Cat was producing an album of this guitar player's music. Once again it was one of those accidental things. The local studio had used me a number of times, and they were going to do the project there. They wanted to try somebody different, and there I was. We did that project, and then Cat Stevens was about to do an album of his own. He had talked to Steve Gadd quite a bit about playing, but Steve was very busy at the time. So I was like number two; if Steve didn't do it, I was going to do it.

SS: That's a pretty good position to be in.

BB: I was very, very flattered! I was the one who got the call to go over to Europe to start the record. We started it there and then came back and finished it in the States. So I ended up being on the *Izitsa* record, along with Andy Newmark.

SS: Flim & the BB's is geographically split now, with members on both coasts, but it doesn't seem to matter. What's your schedule like as a band?

BB: We always take time to get together and do these compact discs and, as you see, we do some concerts. I'd like to do

more, myself. There is a scheduling problem, though, with all the various things we do. Dick does a lot of European work and plays with the Mel Lewis big band in New York, Billy does a lot of scoring and writing for films and commercials, and Flim plays with Allan Holdsworth and many top-notch L.A. bands. So it's tough getting everybody together, but it's certainly worth it when we do.

SS: How do you keep your chops together between projects with the band? Are you very involved now, musically, outside of the BB's?

BB: Oh yeah. I'm a member of the Wayne Johnson Trio. I play in a quartet with an excellent bass player from L.A., Gary Willis, who played with Wayne Shorter a couple of summers ago. There are various other things, too. I play with a couple of *The Tonight Show* band guys in local clubs. I just try to keep active, keep my animation career going, and be a father and husband, too. I'm pretty full up.

SS: Flim & the BB's compositions seem carefully crafted, but the albums sound very

improvisational, too. To what extent do you plan your drum part for a tune?

BB: We have a forum when we get together. We'll work through a tune, and as it keeps getting played we formulate our patterns, our idea of what we would like to do, and what would help the tune along. We decide what tempo, what we want to do rhythmically, and if we want to make it an ethnic thing or something else. Nobody really says, "Hey, you do this" or "You do that." We might suggest things. They come out sounding the way they do because we play them a number of times and get them to a certain point. Then we take them into the studio, and that's the place where we can hear them back and start to really evaluate what's happening or what's not happening.

SS: Does the direct-to-digital process pose any particular problems for you as a drummer, other than the obvious necessity to play with as few goofs as possible?

BB: That's the great challenge, to be in a live situation. We do many takes, and we

continued on page 70

Getting The Right

For the last several years, I've given seminars on the role of drums in the studio from a drummer's perspective. To be honest, around 1985, I wasn't sure I'd ever be giving these talks again, as the whole realm of studio life was changing so as to preclude the drummer. Even the geography of studios conspired to eliminate acoustic drums, with floor space growing smaller and control rooms larger to accommodate MIDI keyboards.

Thankfully, things have settled down. Witness Jeff Porcaro's observing that many L.A. studios have been tearing down walls to create space for rhythm sections to spread out. In my own neck of the woods, I was pleased to get calls from little jingle studios who were tired of drum machines and sick to death of kneeling before the altar of predictability. So real drums are *back again* in a big way.

But I discovered during my lectures that over the past decade, many drummers and engineers have forgotten what to do to ensure that a good drum sound goes to tape. Many drummers assume that their dream sound will mystically arise *somewhere* in the tangle of cables connecting the microphones to the great intimidating mixing console.

While it's possible to do amazing things with outboard processing (reverb, echo, EQ, Simmons enhancement, etc.), there is *no* substitute for properly preparing and tuning drums with the microphone in mind. I've been called in to redo tracks where the drummer played perfectly good time with a pretty decent feel, but his drums just didn't have the *right sound*. The theme of my seminars was that 90% of the battle is getting a good sound *before* a single microphone is ever put in place.

Bass Drums

A sound technician once told me that there's really only *one* bass drum sound, and that's one with a good "slap" followed by a "whomp" in the lower mid frequencies. While in my heart I'm inclined to disagree, for expedience we could adopt that notion for now.

The first thing is to ensure that the batter head is serviceable. If it's dented and pitted, chances are it's

ready to be cut into 3" X 6" patches to protect a new head at the point of beater contact. Speaking of new heads, *all* drumheads work well in the studio. Take it from someone who has just bought two very old bass drums with calf heads. Plastic heads are even and consistent, so it's really a question of the sound you want.

Once your batter head is in place, take it from the point at which it's loose and flappy, and give each tension rod about a 360-degree turn. Be sure the head is evenly tensioned all the way around; we want the drum to have maximum resonance. Whatever you do, don't stuff a bass drum full of pillows. All that does is reduce the available mass of batter head, effectively converting a 24" bass drum into a muffled 12" tom. Place a shallow pillow lightly against the batter head, and experiment with pressing and anchoring it more firmly while adjusting head tension. The Remo *Muff'l* works really well, but it must be installed *before* your new bass drum head.

When all is done, listen to the sound. Odds are if your bass drum sounds too flat and trebly, that's what will go to tape. If the note is too long, you might want to push the muffling a little further up against the head. In any event, remember that we're dealing with a *drum*—a large drum at that—and we want to preserve the integrity and proportion of that drum to the rest of the set. There is no legitimate reason for stuffing it full of blanket just because it produces a big sound. It's *supposed* to produce a big sound.

Try this: Get someone to play the drum while your ear approximates where a microphone would be placed. Pull the muffling out of the

drum and notice the overtones and afterring. Then reinstate the muffling. If you've succeeded in preserving the fundamental sound of the drum, while reducing some of its complexity, you're probably just about there. If it sounds too boxy, reduce the muffling and check that the drum is not too tightly tensioned. Always take the way a non-drummer strikes your drum with a grain of salt. Mentally add a little more for the way *you'll* strike the drum with that extra confidence.

Muffling and tuning should go hand in hand, and the relationship that suits you will become easier to achieve each time you try it. When all is said and done, and you haven't quite achieved the sound you're looking for, there is still something yet to try: *beaters!* Try hard, flat plastic beaters, wood beaters, soft and hard felt beaters, and acrylic beaters. All these will introduce varying degrees of attack, click, simulated low end, and so forth. It's no great investment to carry a few extra beaters, and having that option can give an engineer a slight variation on your basic sound without having to adjust any EQ.

A final note on bass drums: You'll most often be recording with one head on the bass drum, or with a hole cut into a muffled head for the microphone. I've used an intact front head in the studio with good results, but it can be a pain, and it's not what engineers and producers are generally looking for.

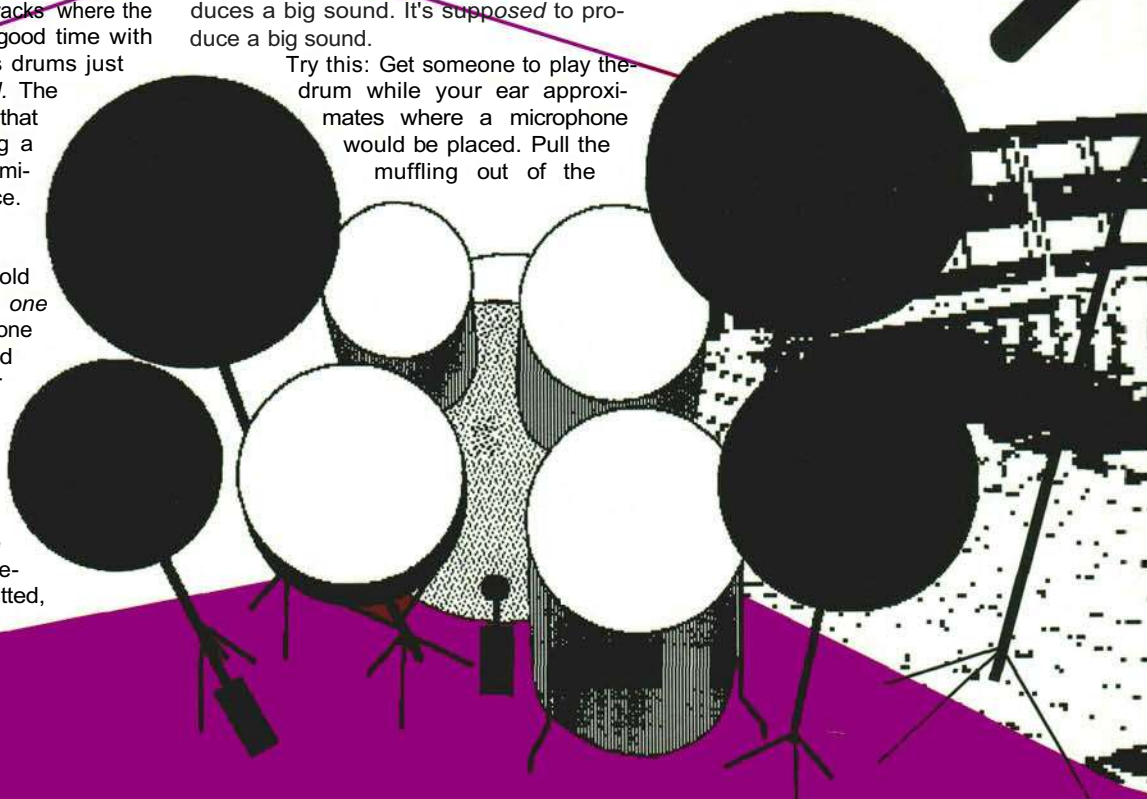

Sound In The Studio

Snare Drums

I've gone into the studio on the heels of a band packing up, and upon checking out their drum tunings, have smiled at some pretty perverse snare drum tunings. I've seen \$600 snare drums radically altered. I remember seeing a Ludwig 400 with a Duraline head on top, muffled *underneath* with cloth, an extremely loose bottom head, and snares tightened up enough to raise the pitch of the drum. To add insult to injury, a piece of Scotch tape was placed across the snares, presumably to quell after-buzz. I really feel for the drummer who did all that, but it was a misguided attempt at making a 14" drum sound like a backbeat someone heard through a 3" car speaker.

The snare drum is loud, has overtones, and is even more complex because there are wires underneath that are *intended* to rattle in sympathy. If you kill all these factors, it's not surprising that you won't have your dream snare drum sound. Here's what to try: Get new heads, top and bottom. Then attach the snare strands to the strainer and butt with good, woven string or glass tape. Fasten the snares, but not *too* snugly. Nothing destroys a good snare drum sound more than having the snares so tight that they strangle the bottom head. They should be tight enough so that when you play at various dynamic levels, you can hear the figures you're executing. In fact, if the music requires only a backbeat, you can keep the snares quite loose. This helps you achieve the much coveted "fat" sound without having

to overly loosen the batter head. However, you may need a little muffling.

Kenny Malone once talked about the effect of various grades of paper on the sound of the snare drum. Taking his suggestion, I sometimes fasten a piece of parchment-type paper (2" X 4") to the rim of the drum, leaving it free to jump up on stick impact and then settle back on the head. Often this is all that's required, and if not, what's cheaper to experiment with than paper?

Zero Rings work very well, as does duct tape. The LA. trick of putting a ridge in the center of the tape before affixing it to the drum seems to work. The object is to muffle out only those frequencies that sound odd or discrepant, once every attempt has been made to tune the drum evenly. The trick with the snare drum is moderation. Ensure that with snares off it emits a pure tone—almost as if it were a first tom, and thus higher in pitch than your first tom (but not too high).

Top and bottom heads could be similar in tension, with the bottom heads maybe a *little* tighter. Again, experiment. *Ambassadors* are good all-around heads for snare drums, with *Diplomats* on the bottom. However, I've used batter-side heads such as *Fiberskyns*, *CS Reverse*, *Emperor* coated, *Aquarian*, and *Canasonic*. The thicker the head, the less muffling you'll need.

Possibly more important than the way you tune your snare drum is the way you strike it. I can remember being wretched for years trying to reconcile pleasing engineers (all of whom wanted deep, fat snare drums) with my own desire for more of a pop/ringing sound. These days the fat sounds peacefully coexist with the skinny sounds, and we hear records with both.

I enjoyed Phil Gould's revelation that in attempting to emulate

center. Even *touching* the rim was verboten. Hitting a rimshot for a backbeat, to paraphrase one engineer, "reduces the efficiency of the drum and cancels out low frequencies." That's probably right in hindsight, but who wants just another tom-tom with snares on the bottom anyway?

Experiment both ways, and try to control overtones by solidifying the way you hit the drum. When playing backbeats, hit at the *same* intensity and in the *same* place on the drum throughout a musical phrase. Watch the VU meters during playbacks. The needle for the snare channel should go to the same spot each time. With a moderate snare drum tensioning and head combination, and by hitting dead center or rim center, you can get both dead and live, ringy sounds out of the same drum.

One last thing about snare drum sounds is a phenomenon my engineer friend Phil Bova calls the "fiddler crab syndrome." The fiddler crab has one long arm and one tiny one. Phil finds similarity in some of the younger drummers who come through his studio. Invariably, if there's a problem getting a sufficient signal on the snare channel, and yet buckets full elsewhere, it's the result of the little arm hitting the snare drum and the great big arm wholluping a half-opened hi-hat.

Work on making the snare drum as predominant in your drumset execution as you would expect it to be on the ultimate mix. If you don't, in order to increase it during mixdown, increasing the level will mean increasing everything else that may be bleeding into the snare mic'—like those hi-hats you've been beating to death.

Tom-Toms

Rules are made to be broken, and I suggest

that the *fewer* tom-toms used the better.

Fewer toms means ease of setup, fewer mic's, fewer tracks, cleaner sound, and real distinction in pitch. Of course, you read stories about Simon Phillips walking into the studio with eight toms, using only one mic' per two toms, and getting a killer sound. But rather than letting this be a standard to follow, let it rest as a tribute to Simon's incredible ability to control the sound going to tape by striking each drum to produce even attack and volume.

If you're going to use two or three toms, let them be of distinct diameters and pitches. It's no good having three or four small toms

Dave Mattacks' signature snare drum sound, he would have to strike the drum consistently, hitting both rim and head simultaneously. To some this may seem less than skies opening/water parting, but drummers past their 30's lived through a period where you had to hit a snare drum smack in the

Achieving That Certain Sound In The Studio

Now that you've got your drums in shape, it's time to consider what kind of music you'll be playing. Make this determination now. It will help you decide on your final drum sound and dictate adjustments. Here are a few ideas.

THE JOHN BONHAM SOUND

Get your tuning key out and take all the drums up a semi-tone higher than you'd think. Next, remove every speck of dampening in the bass drum, crank it up, and use a very hard beater. Hopefully, your snare is metal, not quite tabletop tight, and rimshots all the way. With a highly tensioned snare, the rimshots can sound a little thin, so play with the butt end of the stick. This makes all the difference. No muffling.

THE STEVE JORDAN SOUND

Keep the tuning key in your pocket, but turn the stick around so you're hitting rimshots with the bead of the stick. Also, play the snare a little away from center to enhance high-end cut. Put a little of the muffling back in the bass drum.

THE JIM KELTNER SOUND

Back off on the tuning of all the drums without loosening them too much. Use the stick to find the sounds each drum is capable of producing. Little if any muffling on the snare, and use the bead of the stick. Try Aquarian sticks for a nice high-end rimshot without having to actually tune the drum as high as you'd think.

THE BRYAN ADAMS SOUND

Keep everything tuned medium and hit the snare with a rimshot for every backbeat. You'll need to hit hard, keep your tom fills simple, and get a flat sound with enough life to cut through the guitars.

THE STEVE GADD SOUND

Tension the snare medium high, muffle with a *Zero Ring*, tighten the snares snug against a medium-tight bottom head. Loosen the batter heads on the toms a little. Don't go for ring, but for a very organic, deep, and resonant sound. *Get your chops together!*

all tuned a semitone apart. There won't be enough drama in that to accomplish anything musically. Credit should go to Steve Gadd for bucking tradition and using 10" to 15" toms. Smaller toms are easier to control and easier to mike since there's less head space for a mic' to comprehend. And they sound great. I try to use two, sometimes three, and space the diameters a few inches apart. My favorite setup would be a 10" in a deep depth, a 12", and a 14X14.

Be sure the heads are not pockmarked. If they have craters like the moon it's just not going to happen in the studio. On a live gig you could crank up the tension and forget about it, but in the studio you may want to bring the tension down a step or two. If your heads are dented, you'll get an annoying buzz and rattle.

If I were doing my first demo, I'd probably have a new *Pinstripe* on top, and an *Ambassador* or clear *Diplomat* on the bottom. Evans also makes some great heads, such as the *Rock* and *Hydraulic* for the top, and the *Resonant*, especially meant for the bottom. Aquarian makes a head that I've had luck with called the *Studio X*. But there's nothing that says you must have the same head type on each drum. I once noted a session drummer with a *Diplomat* on his snare, *Ambassadors* on his rack toms, and an Aquarian on the floor tom. This approach is particularly valid if you're combining different brand drums. A thicker-shelled, 6-ply Ludwig might want a thinner head to blend with a thinner-shelled 6-ply Gretsch.

Toms should be tuned to medium tension with both heads as close in pitch as possible. Tensioning should be even. If you find it difficult to hear differences in pitch when tapping around the head, hold the drum up to the light to spot any rippling. Experiment by bringing the bottom head up or down in pitch. You'll get an idea of what this does by hitting the batter head while adjusting one lug on the bottom. Generally, the thicker the top head the tighter the bottom. At the very least, with both heads at mid-tension, and top and bottom same pitch, you'll always have a recordable sound. Another thought is to use an *Emperor* clear on the bottom to enhance lower frequencies, instead of the usual 1-ply, thin head. It can help to eliminate the "boinginess" inherent in a *Diplomat*-type head in certain studios.

Whatever you do, *don't* over-muffle. Try little pieces of duct tape close to the rim. You may find that in a set of three toms, only two need muffling while one sounds perfect. There's no rule that says *all* drums must be muffled just because it was necessary on one. In fact, you may not require muffling at all if you've taken the time to tension the drums.

TomMounting

The disappointing thing about tuning toms is that, although you can get them sounding nice when you hold them up

and hit them, the minute you put them on their holders they sound like someone sucked the life out of them. One alternative is to mount your toms on snare stands, and don't tighten the basket arms like a vice. If you can live with the angle and height this arrangement affords, you're on your way. If not, you'll need to tune the toms while they're on their holders. This way, there won't be a huge discrepancy when you return them to their proper mounts.

The other well-documented way of dealing with the problem is to use RIMS mounts. I did studio work without RIMS for many years, thinking I'd never notice sufficient difference to justify the investment. Now I wouldn't dream of recording without them.

During the seminars, I got an audible gasp from the students at this next trick—in effect a "poor man's" RIMS. I sat a well-tuned floor tom on its three legs and hit it hard, asking the students to note the tone and decay time. It sounded pretty nice. Next I took three 4" blocks of thick foam and put one under each leg. I hit the drum again. A full second of decay time was added, and the bottom end seemed to increase enormously. This neat little device is cheap, effective, and particularly noticeable when there's a hard floor or tight pile carpeting.

Playing Tom-Toms

The important thing to remember when executing a run from a high to a low tom is to hit them with *equal* attack and volume. Don't trail off when you near the end of your sequence. If anything, train yourself to increase your attack slightly as the diameter of the drum increases. It's a fact that you must hit a large drum *harder* for the whole unit to respond effectively. It's just as important to strike the drum with a confident stroke, and release the stick before it's allowed to stay on the head and choke the movement. An evenly tuned tom can sound just awful one moment and beautifully resonant the next, just by varying the stroke and bringing the stick straight down dead center, or just off center parallel to the head—and then getting it out of there in a hurry.

If you need more tom sounds you can add a RotoTom. I use one as a timbale, always striking a rimshot. You can also tune up a spare 12" tom really high. Both ideas come from Jim Keltner. Jim uses one small and one large tom, with thin heads tuned medium-high to medium respectively. He claims he gets a minimum of four sounds per drum, thus emulating the sound of an eight-tom set with only two drums.

Weeding Out The Problems

It goes without saying that you always want to take care of rattles, loose nuts, mangled snare assemblies, squeaky pedals, etc. You do as much of that as possible at home.

continued on page 80

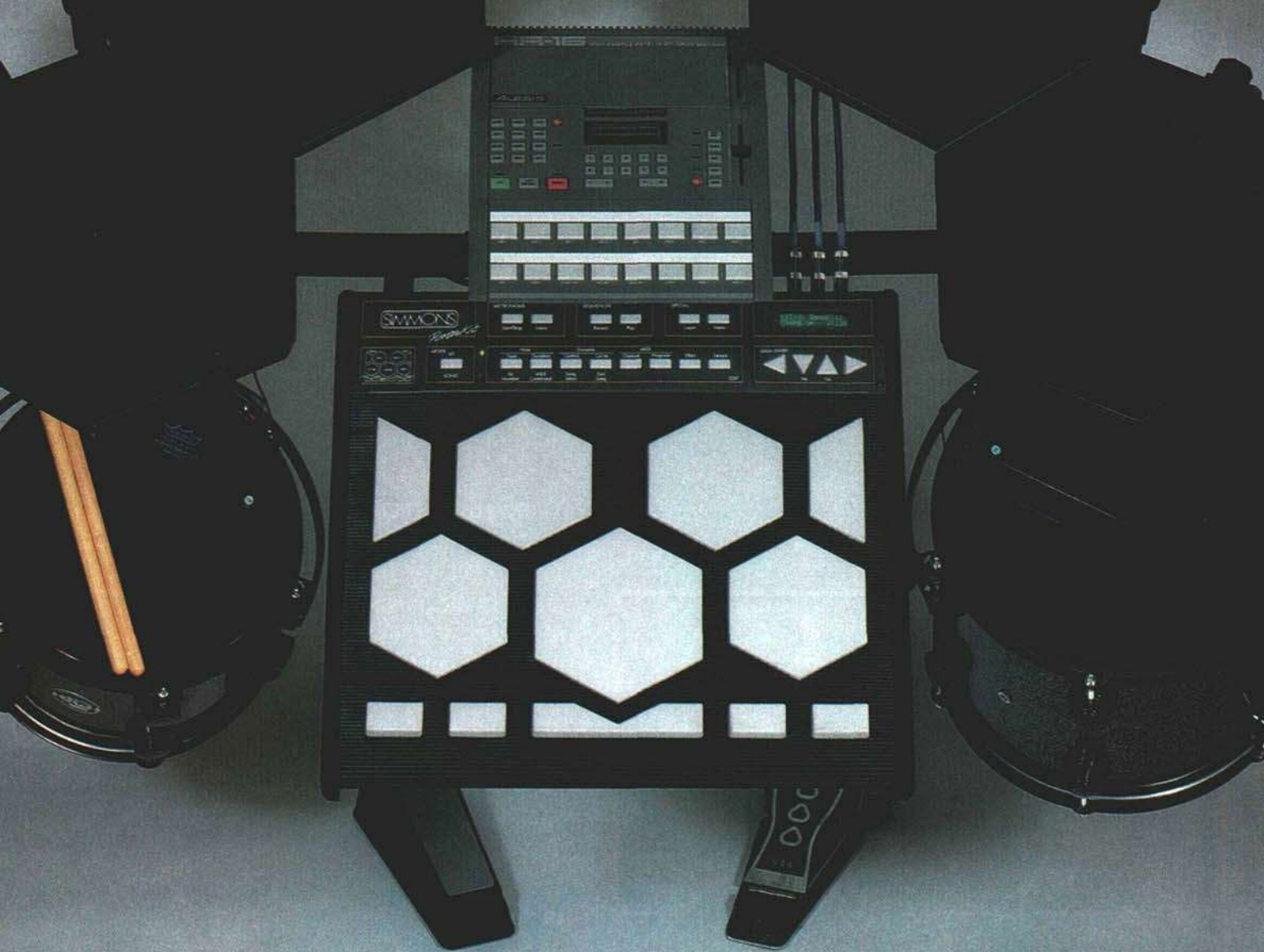

At Simmons, we don't think eight is enough

That's why we gave **The Portakit** 12 pads, so you can trigger *more* sounds from your drum machine or sampler.

And we didn't stop there!

When you play **The Portakit**, you'll find the pads to be super sensitive and dynamic with *no* crosstalk, thanks to "FSR" technology. You'll also find the "drum set" layout comfortable to play – you can even plug in bass drum and hi-hat pedals.

Triggering from acoustic drums is easy with 6 "**Learn**" inputs, and 50 memory patches give you plenty of room to store custom MIDI setups.

You can record your performances in a 10,000 event sequencer and reach a new level of expression with a range of MIDI effects, controlled from a footpedal or "*performance pad*".

SIMMONS

A full range of accessories are available, including acoustic drum trigger bugs and a drum stand mounting bracket.

There's even a metronome, should you wish to play to a click, and you can chain 2 or more **Portakit**s together using the MIDI Merge facility.

The Portakit — the portable MIDI pad set that gives you 12 pads *and* a whole lot more. Sometimes, 8 *isn't* enough.

MEET OUR QUALITY

David Garibaldi



Mino



*3rd
Sheila E.*



There are five quality control points at our factory. Yet, the final one is in the hands of the artist. These drummers and percussionists could play anything. But they have made their choice with Paiste. We'll let David, Mino, Sheila, Ed, Joe, Emil, and Narada tell you in their own words.

Then, find out for yourself what it took for these fine artists to stick with Paiste. Visit your local dealer and play a Paiste cymbal—the best quality—and consistency—you can find... anywhere.

PAiSte
CYMBALS SOUNDS GONGS

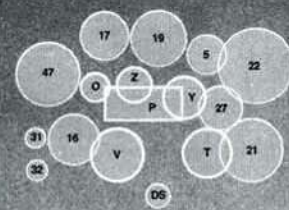

DAVID GARIBALDI

...I view the cymbals as a real important part of the drum set...I really like the Sound Creations and the 3000 Thin Crashes...I remember hearing Paiste cymbals on recordings and always liked the brightness of them...all the other companies have all the exotic sounds because of Paiste...I am very pleased with the quality of the instruments, and they fit well with contemporary music...

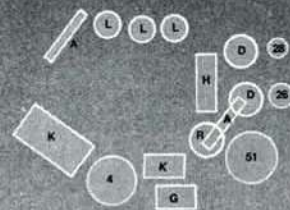

MINO CINELU

...as a drummer and percussionist I have always felt that my setup would be incomplete without cymbals...I have always been lucky to perform with artists of very diverse musical backgrounds and in all situations...my Paiste cymbals have allowed me to brighten accents, create ambiances and complete the harmony played by other instrumentalists...

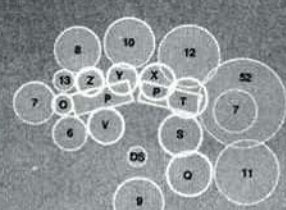

SHEILA E.

...obviously, sounds are as individual to an artist as the way they play...Paiste cymbals complement my music and my style, if they didn't, I'd have to play something else...Paiste has improved and advanced throughout the years in technology, quality and sound, just as I have advanced and grown throughout the years...so, it's kind of hand in hand...we grew up together...

CYMBALS, SOUNDS, GONGS

- 1—1000 Hand 18"
- 2—2000 20" China (pr.)
- 3—2000 8" Splash
- 4—2000 Color Sound 20" China—red
- 5—2002 11" Splash
- 6—2002 13" Heavy Hi-Hat
- 7—2002 16" Crash
- 8—2002 17" Crash
- 9—2002 18" China
- 10—2002 18" Crash
- 11—2002 22" China
- 12—2002 22" Ride

- 13—2002 8" Splash
- 14—3000 13" Medium Hi-Hat
- 15—3000 14" Crash
- 16—3000 14" Medium Hi-Hat
- 17—3000 14" Thin Crash
- 18—3000 16" Crash
- 19—3000 16" Thin Crash
- 20—3000 17" Crash
- 21—3000 17" Thin Crash
- 22—3000 20" Ride
- 23—3000 22" Ride
- 24—3000 8" Bell
- 25—3000 8" Splash

- 26—3000 Rude 10" Splash
- 27—3000 Rude 13" Hi-Hat
- 28—3000 Rude 8" Splash
- 29—500 Band 18"
- 30—Crotales—2 Octaves
- 31—Cup Chime #4
- 32—Cup Chime #8
- 33—Formula 602 20" Heavy
- 34—Formula 602 14" Medium Hi-Hat
- 35—Formula 602 18" Paper Thin
- 36—Formula 602 18" Thin Crash
- 37—Formula 602 20" China
- 38—Formula 602 20" Paperthin

- 39—Formula 602 20" Thin Crash w/rivets
- 40—Formula 602 22" China
- 41—Formula 602 22" Paperthin
- 42—Paiste Tuned Gong
- 43—Sound Creation Gong #2
- 44—Sound Creation Gong #3
- 45—Sound Creation Gong #4
- 46—Sound Creation Gong #7
- 47—Sound Creation New Dimension 16" Dark Crash

CONTROL TEAM

Ed Mann

Joe Porcaro

Emil Richards

N. Michael Walden

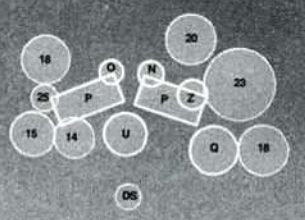
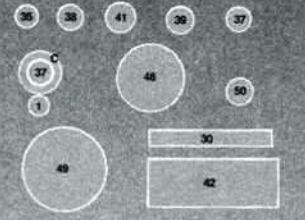
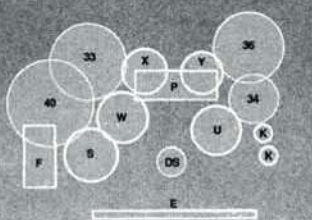
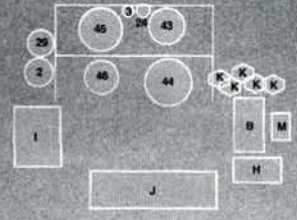

ED MANN

...Paiste metals provide the ability to highlight dynamic range within music... I don't know of any other company that has created this variety of sound textures... I used everything from 500 Series Band cymbals to the Sound Creation gongs on the last Zappa tour, and they really projected and added a wide range of color to the ensemble... it's obvious, a lot of work has gone into the creation of these sounds...

JOE PORCARO

...the Formula 602 are very sensitive cymbals, very sparkling sound... when I need another color, I can go to the 2002s... one of my favorites is the Formula 602 22" China, when I use that, I get all kinds of compliments... I love the different sounds I can draw from, to fit any musical situation... they're very musical cymbals...

EMIL RICHARDS

...Paiste has been the best thing that's happened to cymbals, gongs and crotales in a lifetime... the products sound great and perform perfectly because the people at Paiste care, and are dedicated to making what you hear, want and need in your instruments, happen...

NARADA MICHAEL WALDEN

...it's important that a cymbal cuts... Paiste cuts like a sharp razor blade of love to your heart... I like every Paiste cymbal... the more, the merrier... Paiste gives me the edge...

DRUMS & OTHER INSTRUMENTS

- 48—Symphonic Gong 28" with bowing hole
- 49—Symphonic Gong 32"
- 50—20" Prototype Hand Cymbals
- 51—20" Prototype Ride
- 52—28" Prototype Flatride

- A —Wind Chimes
- B —Vibraphone
- C —Timpani 28"
- D —Timbales
- E —Percussion Tree
- F —Octopad
- G —Iron Percussion Instruments
- H —Hand Percussion
- I —Electronic Racks
- J —Electronic Mallet Instruments
- K —Electronic Drum Pads
- L —Conga
- M —Bell Tree & Orchestra Bells
- N —9" Tom Tom

- O —8" Tom Tom
- P —22" Bass Drum
- Q —16" Floor Tom
- R —15" Snare Drum
- S —15" Floor Tom
- T —14" Tom Tom
- U —14" Snare Drum
- V —14" Piccolo Snare Drum
- W —14" Floor Tom
- X —13" Tom Tom
- Y —12" Tom Tom
- Z —10" Tom Tom
- DS—Drum Stool

The statements in this ad are based on interviews conducted with the artists on their playing, cymbals, sounds, and on Paiste. Write to us and ask for the ones you'd like. Mention Dept. USA5. Please include \$3 for cost, postage and handling.

Premier XPK Drumkit



Premier has given a brother to their *APK* drumkit line. While the *APK* kits are finished in plastic covering, the *XPK* kits offer three different lacquered birch veneer finishes, along with a few other differences. The *XPK* has mahogany shells finished in black on the inside, plus high-tension double-ended lugs, which are the same lugs as those used on Premier's *Resonator* series. Components of the five-piece *XPK* kit are: a 16 x 22 bass drum, 11 x 12 and 12 x 13 rack toms, a 16 x 16 floor tom, and a 6 1/2 x 14 steel-shell snare drum.

Bass Drum

The 16 x 22 *XPK* bass drum has eight double-ended "stretch" lugs with T-handle tuners, except for at the bottom of the drum, where key rods are used instead. Beech hoops, painted black, are fitted onto both sides, and there is a small piece of rubber adhered to the batter hoop for pedal mounting. The hoops alone are 3/8" thick. With the rubber pad, some makes of pedals will not clamp onto the hoop (DW is one), making it necessary to remove the rubber altogether. The drum has external fold-away spurs, each of which has a telescopic inner leg, released with a drumkey set screw. The leg has a spike-point tip with a rubber cone surrounding it. Each spur can be set at any desired forward angle by simply releasing the T-bolt and moving the entire spur leg against its mount plate. I didn't

have any problem with the drum creeping forward; the spurs kept the bass drum quite secure and stable.

The drum came fitted with a Premier *DS* batter head, and a black *Megasonic* audience-side head. Premier's *DS* drumheads are transparent two-ply plastic, with a dampening ring in between the two plys. The *Megasonic* is one-ply and has two pre-cut holes (2 1/2" and 8 1/2") for quick air release, as well as for miking purposes. Each hole has a white dampener ring around it.

With this particular combination of heads, the drum really didn't require additional muffling. It had a deep, round, loud tone on its own, mixed with good attack. While a blanket or foam placed inside may further cut down some overtones and "tighten up" the sound, volume would probably be decreased some.

Mounting System

The *XPK* tom holder utilizes a single 19" chromed down post that mates with a larger receiver plate mounted in the center of the bass drum. Atop the tube is a holder system using two independent L-arms with ratchet adjustments. The arms are fully adjustable for angle and spread, but, of course, not for height. Each L-arm has a small movable positioner sleeve, which will brace against the flat side of the drum's mount bracket—basically a variation of the tongue-and-groove memory ring (which the down

tube has). The tom brackets fit and lock onto the L-arms via a T-screw and eyebolt setup; nothing passes through the drum.

Once everything is locked in place, the holder is pretty stable. (I was able to turn the drums a little by hand.) The elongated down post allows for acute drum angles if needed, without the fear of the toms sitting right on the bass drum shell. Many other manufacturers have taken to placing the holder plate near the front of the bass drum. Due to the use of L-arms, Premier's center positioning works fine and actually relieves stress on the bass drum shell. The toms can be conveniently placed, without coming too far past the bass drum's batter hoop. All in all, the holder is uncomplicated, and is easily set up and broken down.

Tom-Toms

The 11x12 tom has five double-ended lugs (odd for a 12" drum); the 12 x 13 has six. Both of them are double-vented, and have no internal muffling. The 16 x 16 floor tom has eight double-ended lugs, as well as three legs that locate into eye-bolt brackets. All the toms came fitted with Premier's *DS* batters and *CL* (transparent single-ply) bottoms. Because of their "extended power" dimensions, the two rack toms had deep tone at normal head tension, with good volume. The floor tom was "throaty," and was capable of being tuned down to timpani levels! All three drums spoke quickly and responsively, especially the 12" and 13" drums, due to their two ventholes. The Premier heads, I've found, give added stick attack sound to the drums. This could be a plus or a minus, depending on the overall sound you want. A Remo *Pinstripe* on the batter side softened up the sound a bit, and rounded it out a little more.

Snare Drum

One difference between the *XPK* and *APK* kits is in the snare drums. While both kits have steel-shell chrome-finished snare drums, the 7036 drum that comes with the *XPK* has a center reinforcing bead for greater tensile strength. This 6 1/2 x 14 snare has ten double-ended lugs, pressed hoops, and a side-throw lever strainer. The throw-off side has the usual fine-tension knob to adjust the 20-strand wire snares (which are held with cord), and the butt-end clamp is serrated to better grip the cording. The bottom hoop is cut away at the snare beds, enabling the snares to drop to their fullest. A coated white Premier *TS* head was fitted to the batter side. A plastic overlay ring was also included to dampen out some of the drum's inherent metallic overtones.

Right out of the box, the drum had a bad snare rattle, and I had to totally re-set up the snares. After that problem was attended to, the drum produced a snappy, alive, high-pitched sound (a la Stewart Copeland). The drum was also very playable at lower

tunings, while still retaining its crispness. Compared to the other drums in the kit, the snare lacked some volume (but not so much as to bury its sound). Rimshots were quite powerful, though. I've always enjoyed Premier's snare sound (sort of orchestral, to me), and this drum is a good example of why.

Hardware

The *XPK* drumkit comes with Premier's 4000 double-braced hardware, rather than the 3000 single-braced stands packaged with the *APK*. The *XPK* kit reviewed includes one straight cymbal stand and one short-boom cymbal stand. Both have wide-stance bases, two adjustable-height tiers, and ratchet-set tilters. The tilters feature a built-in angle memory—a small wire clip that can fit into the gear teeth, stopping the tilter at a pre-designated point when setting up. A great idea!

The boom stand's arm is 10" long, and angles via a ratchet/eye-bolt holder. Both stands are very stable, and have certainly more than ample height—over five feet. In fact, with the boom arm in its straightest position, you have a six-foot stand! Yet both stands will fold away quite compactly.

The snare drum uses a flat hinge tilter, and holds the drum in a basket. A long T-

screw at the bottom of the basket adjusts the arms to firmly clamp the drum. This stand folds from the bottom, making it easy to reduce leg spread—thus making room underneath for any extra pedals you might be using.

Speaking of pedals, the 254 bass drum has a hinged footboard, a single expansion spring, and a flexible fiber strap. Tension is adjusted at the base of the spring holder via a knurled knob. A hexagonal axle holds the beater housing, which is adjustable for position with an allen screw. The pedal clamps to the hoop using the common wing screw/plate method. A felt beater is included. The pedal I tried had a lightweight feel and good response. With Premier's "back-to-basics" design, they've shown that a pedal doesn't have to have a million adjustments to feel good and work well.

Like the rest of the 4000 series, the hi-hat stand also has double-braced legs, and its footplate matches the bass drum pedal. A fat chain linkage is used, and tension is adjustable via a large notched plastic wheel at the front of the stand. A visual gauge indicates your tension setting (heavy to light). On the stand I tested, the wheel moved stiffly, requiring both hands to rotate it. (I've seen other hi-hat models using this system that worked effortlessly.) The

height tube has a hose clamp for use as a memory setting, and there are two sprung spurs at the base of the frame. (Come to think of it, the bass pedal doesn't have any.) The stand had a springy feel, and the footboard angle was sloped too much for me. From what I can tell, this cannot be altered. (If you play the hi-hat heel-up, this may not be much of a problem.) Aside from those criticisms, it's silent and smooth.

Cosmetics

Premier's *XPK* kit is available in three different lacquer veneer finishes: rosewood, dark walnut, and black shadow, which was the one I saw. The drums look absolutely gorgeous; the finishing has an extremely professional appearance. Premier's lacquer finishes are truly the best I've seen on any kit in this price range (and may even give some others a run for their money).

Premier's expansion of their *APK* line into the *XPK* series really has me wondering how they can offer such a pro-looking and pro-sounding kit and still manage to keep the price down to what's termed "entry-level." Any beginner or semi-pro who sits at this kit will surely feel he/she's playing a top-of-the-line drumset. At \$1,275 retail, the *XPK* is quite a bargain.

Bob Saydowski, Jr.
continued on next page



Die-Cast, Bell Brass, Brass Mighty, Steel Mighty, Remo Emperor, Remo Ambassador, Remo Diplomat, Die-Cast Cosmo Black, Seamless Copper Shell w/Cosmo Black Freedom Lugs, Die-Cast Cosmo Black, Remo Ambassador Snare, Remo Diplomat Snare, Steel Snare, Air Craft Wire, Brass, Steel Mighty, Bell Brass, Die-Cast

When we say custom, we mean it!

Introducing Tama's custom snare drum program: a unique new way for drummers to create their own snare drum and ultimately, their own sound.

Start with an original: our 6½" seamless copper shell, equipped with freedom lugs and our best roller action strainer, and work from there. By choosing from any of the components shown above, you can

build a snare drum that's uniquely your own.

Each drum is hand assembled and fitted with an engraved plate bearing the purchaser's name and date of completion.

Consult your authorized Tama dealer for all the details. Find out what owning a **custom** snare drum is **really** all about.



For a full color Tama Snare Drum catalog, send \$3.00 to: Tama Snare Drums, Dept. MDD3, P.O. Box 886, Bensalem, PA 19020 • 3221 Producer Way, Pomona, CA 91768-3916 • P.O. Box 2009, Idaho Falls, ID 83403 • In Canada: 6969 Trans Canada Highway, Suite 105, St. Laurent, Quebec, Canada H4T1V8.

Pearl Snare Drums



Pearl recently introduced three new snare drums to their existing line of high-quality drums. One is a maple-shell *Free Floating* piccolo snare; the other two are *Free Floating* and standard-lug drums using a shell material new to Pearl's line: aluminum. This review was written in conjunction with *MD's* Managing Editor, Rick Van Horn, who based his opinions on several club performances using all three drums.

Free Floating Piccolo

The concept of a maple-shelled piccolo snare drum is an interesting one. Lately, many professionals have been playing piccolo drums for the distinctive "crack" that these smaller drums give. Most piccolos on the market today are metal-shelled—either brass or steel. When I heard that Pearl had designed a piccolo snare drum with a maple shell that also used their *Free Floating* shell system, I was expecting a drum that had the high-end attack typical of a piccolo snare, with an added "woodiness" from the maple shell. The results of this combination were, in some ways, surprising.

First off, let me say that the drum itself is very well-constructed. In fact, it's a bit heavier than other piccolos I've played. This is due, in part, to the drum's high-quality die-cast hoops, along with a pretty involved snare strainer and the *Free Floating* system base. The drum comes fitted with a coated *Ambassador* batter head and an *Ambassador* snare head. Like most quality snare drums manufactured today, it has no internal mufflers.

In terms of its sound, this drum was extremely crisp and "snare-y," even when tuned down a bit. Thanks to the die-cast rims, rimshots were easy to play, and boy, did they cut! As expected from a piccolo,

the drum had a clear, high-register sound, and because of its excellent construction, the volume and projection were terrific. It didn't "choke" when played loudly either. When played lightly, it responded instantly with a good snare sound.

As for the maple shell, both Rick Van Horn and I found that this drum's sound was not as abrasive as many metal-shelled piccolos that we have played. However, I was hoping for more of a wood sound. Part of the reason for this lack of "woodiness" has to do with the *Free Floating* shell system. The actual base on which the shell sits is a fairly massive piece of steel. In fact, it rises up almost half the depth of the 3 1/2" drum. So, in essence, you're getting a drum that is half wood and half metal. On larger drums, the *Free Floating* system base is a much smaller percentage of the total construction. On a piccolo, however, it accounts for a larger portion of the shell.

After mentioning all of this, I must say that this is *not* a problem. Actually, most drummers might see it as an advantage in that this drum gives you a sound somewhere between that of a metal shell and that of a wood shell. Pearl may want to experiment in the future with a maple-shell piccolo fitted with normal lugs. That might provide more of the wood sound we were expecting from this drum.

One problem with the piccolo is the drum's snare strainer. It's a very involved unit, which some people might like. Rick Van Horn mentioned that when playing the drum on a gig, it was difficult to fine tune the snare strainer because it was so involved. The strainer itself protrudes about 3" from both sides of the drum. You would have to be careful when putting the drum away, because it would be possible to

damage the strainer on an edge of a case. Also, we found the snare throw-off to be very noisy and not very smooth. In a louder musical setting, this may not be a factor, but it is something to take note of.

The drum came equipped with a 20-strand wire snare, which was attached with plastic strips. A unique design of this Pearl strainer (which comes with all of the *Free Floating* models) is the adjustable bridges located underneath both sides of the drum. The plastic strips that hold the snares rest on these bridges, allowing the snares to be pulled evenly across the drumhead. These bridges are easily adjustable with a screwdriver, so you can set the desired snare re-

sponse. However, it's not something that you could do between tunes at a gig.

Overall, we found this piccolo to be a very good drum. Even though there are a few minor problems with the snare strainer, the drum itself sounds good and is well-constructed. Again, if you're looking for a piccolo drum that combines some of the sound qualities of a wood shell with those of a metal shell, this might be the one for you. Retail price is \$390.00.

Traditional Aluminum

One of the aluminum-shelled drums Pearl sent us featured their traditional-style high-tension lugs (as opposed to the *Free Floating* design). This model is 6 1/2" deep and features Pearl's own *Super Hoop*, which is quite a bit thicker and stronger than normal hoops. The drum was fitted with a coated *Ambassador* batter head, an *Ambassador* snare head, and no internal muffler.

The first thing that we noticed about the aluminum-shelled drums was their beautiful look: It's a silver lacquer finish that is striking. The shell provided a dry, controlled sound, without the traditional "clanginess" of a normal metal snare. It's a very appealing sound that really makes you want to play the drum.

This particular drum sounded excellent when tuned to a low-to-medium pitch. It was loud and clean, with a very unique presence—something that I assume was brought out by the aluminum shell. As we tuned the drum a bit higher, though, it started to choke up a bit. (Rick Van Horn called it a "soup-kettle sound.") I think this drum, with its traditional shell-mounted lugs, is too deep to successfully reach the upper registers. In the smaller 5" depth that is available, it would probably have that

higher range.

The snare strainer on this drum is different than that of the other drums in this review, because this drum does not have the *Free Floating* shell. This snare strainer was not very complicated and didn't stick out as far on the sides as the others did. It was efficient, and didn't make as much noise as the strainer used on the *Free Floating* drums. I found it easy to adjust to where I wanted it.

This drum would be excellent if you were looking for something to be used in a medium- to low-pitched range. The projection was excellent, and the drum was very solid. The *Super Hoops* worked well for rimshots and especially well for cross-stick playing. The snare response was good and the snare strainer was easy to operate. List price is \$350.00.

Free Floating Aluminum

The 6 1/2" *Free Floating* aluminum-shelled drum was the most impressive of all the drums we were given to test. Again, like the other aluminum drum, it had Pearl's *Super Hoops*, and was fitted with a coated *Ambassador* batter head and an *Ambassador snare* head. This is an even more visually attractive drum than the other aluminum model, with the *Free Floating* design giving it an even more striking look.

Just as with the other 6 1/2" aluminum-shelled drum, this shell produced a clean, dry, metallic sound with a pleasant ring to it. It didn't take much muffling to make it sound good. The drum was loud, punchy, and very playable. Fancier stick work (i.e. rolls, flams, doubles) was very easy to play on this drum and, because of the excellent projection, was very easily heard. This drum did everything the traditional-lug snare did and more. It possessed the capability to achieve the high-pitched tunings that the traditional model couldn't reach without choking.

The snare strainer was the same as on the piccolo drum, so it had the same drawbacks previously mentioned. Again, in certain louder playing situations—where this drum would be most appropriate—the strainer's on-off action loudness wouldn't be noticed.

The drum did lack a bit of subtlety; in other words, it was difficult to play on *softly*. Even a light stick tap produced a fairly loud response, but that just shows its amazing projection. In this size, I'd say this drum would be tremendous for any amplified music application, especially for funk, fusion, or other styles where multiple beats would be played (as opposed to music requiring only simple backbeats with lots of space between them). List price is \$320.00.

—William F. Miller

Wuhan Cymbals

Ah, China cymbals. I have to admit going into this review that I love China cymbals; there's just something about that trashy sound.... I have been known to play gigs with nothing but China cymbals (which is probably why I haven't worked in a while). Anyway, I got the assignment to review the Wuhan *Lion* cymbals because I *do* love Chinas. If you don't like China cymbals, this review might not interest you. However, if you like Chinas even just a little bit, read on, because chances are Wuhan has a cymbal for you.

The first thing that you notice about a Wuhan *Lion* cymbal is its unique shape. Along with the usual turned-up edge that all China cymbals have, a Wuhan China cymbal has a pronounced, uniquely-shaped bell that protrudes away from the cymbal. The bell almost looks as if it were a handle to hold the cymbal with. Another characteristic of a Wuhan China cymbal is its rough look: These cymbals are definitely hand-made. Obviously a lot of physical effort is put into the construction process, and the hammer marks on the cymbals are beautiful. However, because of this hand-construction, there are a few flaws. One flaw I noticed on all of our test cymbals involved the holes, which had very jagged edges and were not always centered on the bells. In this day and age, it's surprising to see a cymbal that looks so crudely manufactured. The most important factor to a cymbal, of course, is how it sounds, but I did want to mention the appearance of these cymbals up front.

12" China

Starting with the smallest China cymbal Wuhan makes, the 12" *Lion* is available in thin and medium weights. Our 12" thin was lower-pitched than the medium, and had a surprisingly low tone for such a small cymbal. Both the medium and the thin 12" Chinas worked well when used for a trashy, splash-cymbal effect and mounted in the normal fashion. When mounted upside-down, both were excellent for quick, multiple hits in rapid succession. They were loud, with the medium weight offering just a bit more volume, and they had almost no sustain; they really barked! I would suggest that if you are looking for a China cymbal at this size and plan to use it in a loud con-



text, buy the medium weight cymbal. The thin seemed delicate and might not hold up to a heavy beating. Both the medium and thin retail at \$82.50.

16" and 18" Chinas

These sizes were among the best-sounding of all the Chinas Wuhan sent. They are available in medium and thin weights, and like the 12" Chinas, the thin models were quite a bit lower in pitch than the mediums. The sound these cymbals produced was loud, brash, and penetrating, with just enough sustain to carry them to the ear, but not enough to be overbearing. These would be most effective as punctuation crashes to "break out" of already loud sound levels. I wouldn't use these sizes for riding on except for medium-tempo, quarter-note ride patterns. Anything faster would be washed out. The 16" thins and mediums retail for \$96.50. The 18" thins and mediums retail for \$127.00.

Wuhan also has an 18" China with rivets that they call the *Splash* China. It was kind of odd-sounding, in that the rivets (which are pop rivets) added to the trashiness of an already trashy cymbal. There was added sustain, but not really enough to drastically change the sound of this cymbal when played loudly. At softer volumes, however,

continued on next page

the cymbal had a very nice sustain sound. It would be perfect in a small-group jazz setting when playing brushes, for instance. The 18" *Splash* retails at \$127.00.

20" China

The 20" *Lion* Chinas proved to be the most versatile of all of the cymbals reviewed. These can be used both for riding and crashing. Again, they are available in medium and thin weights, with the thin being lower in pitch. The 20" thin had a beautiful sound when played softly with ride patterns, and it gave a powerful crash when struck hard. The 20" medium would be perfect for drummers in loud situations who want the trashiness of a China cymbal with the projection and sustain to cut through, which they might not get with a smaller China. The 20" mediums and thins retail at \$160.00.

22" China

When you get up to this size in China cymbals, they become too slow in response to be effective as a crash. The 22" medium was okay as a ride cymbal, giving pretty good stick definition. The 22" thin, however, had an annoying "gonginess" when ridden that got in the way of the definition. Both of these cymbals were low-pitched with a lot of sustain, but as a ride cymbal, I preferred the medium. Both the medium and thin retail for \$187.00.

27" China

Wow! Talk about a big cymbal! The sound of this monster is huge—my ears are still ringing. The only application I see this cymbal working in is with a very loud band, using the cymbal for ride patterns during loud passages of songs. The sound is huge, and I see it being most effective in a

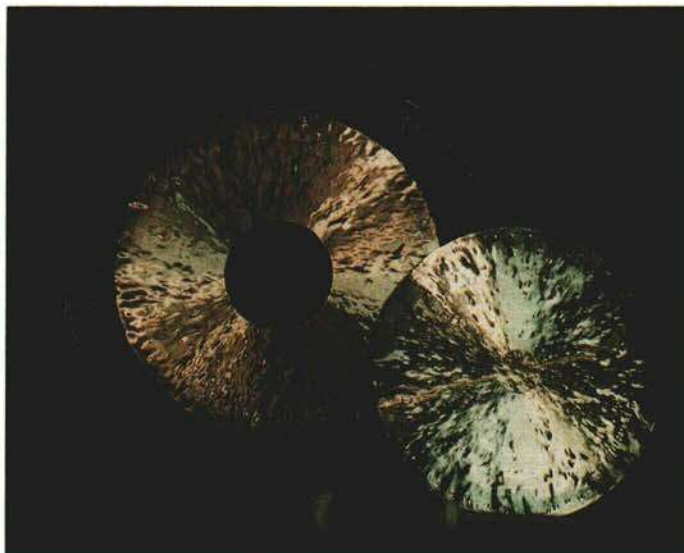

hardcore or metal (pardon the pun) situation. There are two points I'd like to make about this cymbal: First, you'd have to mount it on a very heavy-duty stand, because if you didn't, you'd end up decapitating your guitar player when it fell. Second, I'm not sure if anybody makes a case big enough to cover this cymbal. And even if you could find a case to fit it, the cymbal would still be difficult to carry around. With this in mind, probably the best thing about this cymbal is how it looks. With all of that hammered metal up there, the light shines off of it and makes it look beautiful—and isn't that what's *really* important? This cymbal retails for \$264.00.

Overall, the Wuhan *Lion* China cymbal line is very good-sounding and of good quality. Compared to other brands' Chinatypes, the Wuhan *Lion* series is much trashier sounding (which I happen to like), and they are almost half the price. If you're interested in adding a China cymbal to your kit, be sure to check Wuhan out.

Wind Gongs

Wuhan also manufactures gongs. A *Wind*

Gong is 22" in diameter, flat, and has a lathed finish more similar to that of a cymbal than a traditional gong. It is meant to be mounted vertically, hung by a line strung through two holes located near the edge of the gong.

As for the sound of *Wind Gongs*, all I can say is: very impressive! Played with small gong mallets (which are included), the *Wind Gongs* had a good shimmer and a quick crash when you hit them in the center, and a deep, "wobbly" basso voice when played at the edge. The sound was very gong-like—full and impressive. *Wind Gongs* are very musical, in a size that could be practical for either drumset use or for carrying around by an independent percussionist. We were sent two *Wind Gongs*, and even though the sizes were the same and the basic sound qualities mentioned above were similar, each one sounded unique. A 22" *Wind Gong* retails for \$208.00.

Symphonic Gong

Along with the *Wind Gong*, Wuhan manufactures a line of symphonic gongs. We were sent a 34" symphonic gong for review, which is a *large* instrument. When struck, it had lots of rumbling bottom, with a full, explosive tone. It would be a fine gong in the right application. Unlike the *Wind Gongs*, a symphonic gong of this size would need a special stand to hold it. The retail price for the 34" gong with mallet and without a stand is \$990.00.

For more information on all Wuhan products, contact the U.S. distributor, Paul Real Sales, 1507 Mission Street, S. Pasadena, CA 91030.

—William F. Miller



WITNESS...

TWO AMAZING FEATS PERFORMED ON A SINGLE BASS DRUM.



Pearl's fearless P-882-TW complete twin pedal system constantly amazes audiences with its silent, precise chain drive action. Unlike its noisy chain and sprocket rivals, the sprocket-less P-882-TW relentlessly fights noise with a felt lined "Chair Channel" for whisper smooth artistic response. Its fully telescoping connecting shaft and dynamic universal joint duo bring only one word to mind... Thrilling! To be continued at Pearl dealers everywhere.



The best reason to play drums.

P-880-TW Slave Pedal Unit Only

P-882-TW Two Pedal System

P-880 Chain Drive



SONOR

SONOR

“NO COMPROMISE. A SONOR DRUM GIVES BACK EVERYTHING I PUT INTO IT.”

Chester Thompson plays Sonor Signature drums because after years of performing with the likes of Genesis, Frank Zappa and Weather Report, this world-class drummer knows that you can't compromise when it comes to quality.

Chester says, "A Sonor drum gives back everything I put into it. The Signature Series has extra deep, 12-ply beechwood shells that produce perfectly balanced volume and projection that gives me the big, full sound I'm looking for. Also, with the snap-lock system, the

tension rods won't backup... maintaining tuning accuracy. They also give me the precise attack, increased dynamic range and the sensitivity I demand. Since natural wood appeals to me, I chose the Ebony finish for my own Signature Series set."

So, if you want to hear that no-compromise SONOR SOUND for demanding drummers like Chester Thompson, visit your nearest Sonor dealer and test the full line of Sonor drums.

SONOR

For a free full color, 18" x 24" poster of Chester Thompson, send \$3.00 for shipping and handling to Hohner Sonor Sabian; P.O. Box 9167; Richmond, VA 23227

Distributor for the U.S.:
HSS
Hohner Sonor Sabian
P.O. Box 9167
Richmond, VA 23227
Tel. (804) 798-4500

Outside the U.S. Contact:
Sonor
P.O. Box 2020
D-5920 Bad Berleburg-Aue
West Germany
Tel. (02759) 796

In Great Britain:
Sonor UK
Widcombe Parade
Widcombe Bath BA2 4LD
Great Britain
Tel. (0225) 330089

In Canada:
Louis Musical Ltd.
529, rue Deslauriers St.
Ville St.-Laurent
P.Q. Canada H4N 1W2
Tel. (514) 332-6907

Count!

MUSIC KEY

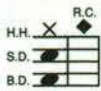

"Count!" "Count the rhythm!" "Count out loud!" "Count 1, 2, 3, 4!" "You're not counting!" Anyone who has ever taken a music lesson probably heard an instructor say something like this. Counting is very helpful for all drummers at all ability levels. In order to understand where you are when you read music, you need to count. To understand the beginnings and ends of musical phrases, you need to count. To feel where beat 1 is, or to not get lost when playing polyrhythms or odd meters, you need to be able to count.

Sometimes, in order to communicate ideas to other musicians, counting helps. For example, I might say, "Larry, try playing those power chords on the &'s of beats 3 and 4 in the seventh measure of the second chorus." If you ever want to do studio work, record dates, jingles, TV, movie soundtracks, or even play in a big band, you need to be able to count. As you become more and more proficient at counting, you'll find that you won't need to count everything. Just like now that you've been walking for a long time, you just do it and don't think about it. But, if you ever get in a situation where you can't quite figure out what a certain rhythm is, or when to start or stop playing, or when to play a certain fill or part, counting *will* help you.

When I do sessions, producers, bandleaders, and the other musicians may make several suggestions about what they want me to play. To remember these types of things, I make notes on the chart. For example, I might write out things like: "Play a fill in the last measure of the second verse; hit an accent on the & of 4 in the third measure of the second verse; don't play the bass drum during the breakdown, add the bass drum on the third beat of the eighth measure, and play a snare fill." Counting helps me to keep my place and know when to play all of those suggestions. Counting will help you work fast, save time, and most importantly, make you look good.

I have come up with some exercises to help you develop your counting ability:

1. If you don't count or read music, first try counting out loud, "1, 2, 3, 4," over and over again while you are playing the drums. Use a metronome or a drum machine to make sure you're counting on the beat and in time. Your voice ends up becoming a fifth limb that you have to learn how to coordinate with your hands and feet.

2. If you do read music, there are a couple of different approaches to counting. One approach is to take a written rhythm and count all of the notes you're playing.

Exercise 2 musical notation: Three measures of music in 4/4 time. Measure 1: quarter notes on beats 1, 2, 3, 4 with counts 1, 2, 3, 4 above. Measure 2: quarter notes on & of 1, & of 2, e of 3, a of 3, & of 4, a of 4 with counts 1 &, 2 &, 3 e & a, 4 & a above. Measure 3: quarter notes on 1, 2, 3, 4 with counts 1 trip-let, 2 &, 3 e a, 4 above. A triplet of eighth notes is shown under the first measure.

Another approach is to count the basic pulse while playing the rhythms you're reading.

Exercise 1 musical notation: Three measures of music in 4/4 time. Measure 1: quarter notes on beats 1, 2, 3, 4 with counts 1, 2, 3, 4 above. Measure 2: quarter notes on & of 1, & of 2, e of 3, a of 3, & of 4, a of 4 with counts 1, 2, 3, 4 above. Measure 3: quarter notes on 1, 2, 3, 4 with counts 1, 2, 3, 4 above.

Practice the following exercises at the drumset, and be sure to count on all four beats of each measure. Play each of the measures individually at first until you feel comfortable, and then play them together as one combined exercise.

Exercises 1-6 musical notation: Six measures of music in 4/4 time. Exercise 1: quarter notes on beats 1, 2, 3, 4 with counts 1, 2, 3, 4 above. Exercise 2: quarter notes on & of 1, & of 2, e of 3, a of 3, & of 4, a of 4 with counts 1, 2, 3, 4 above. Exercise 3: quarter notes on 1, 2, 3, 4 with counts 1, 2, 3, 4 above. Exercise 4: quarter notes on 1, 2, 3, 4 with counts 1, 2, 3, 4 above. Exercise 5: quarter notes on 1, 2, 3, 4 with counts 1, 2, 3, 4 above. Exercise 6: quarter notes on 1, 2, 3, 4 with counts 1, 2, 3, 4 above.

by Kenny Aronoff



Photo by Rick Malkin

7

8

9

10

11

12

After you've learned to play the previous exercises as written, try playing them with the following cymbal patterns.



CANA-Sonic

POWER PLAY "THE DRUMHEAD OF THE 90'S"

The Biggest Advance in Drumheads since the Switch From Calf to Plastic!

The Canasonic Power Play Combines Plastic And Fiberglass!

- Available in Hi-Tech Black
- 5 times more durable than Plastic alone
- Produces Great Stick Action with Plenty of Volume

Designed with the help of some of the Greatest Drummers in the World
Ask for it NOW at your local Dealer or call or write:

CANA-SONIC DRUMHEADS
415 HOWE AVENUE
SHELTON, CT 06484
(203) 736-0969

THE PROFESSIONAL'S CHOICE

LOUIE BELLSON DRUMSET MALLETS

HICKORY AND MAPLE DRUMSTICKS

MARCHING & BASS DRUM MALLETS

TIMPANI MALLETS

KEYBOARD MALLETS



Mike Balter
MALLETS
... THE NAME FOR QUALITY

MIKE BALTER MALLETS
P.O. Box 531 Northbrook, IL 60065
Phone: (312) 498-4787 FAX: (312) 498-6125

Evelyn



Photo by Lissa Wales

This was not just another percussion recital. Yes, there was a multiple-percussion solo, a piece played on timpani, and several selections on mallet instruments. But there was something special about the music: It was so expressive. And there was something special about the musician, Evelyn Glennie. At the conclusion of a moving performance of Keiko Abe's *Michi*, she tapered the last note until it disappeared into her own world. The enraptured audience was cast under her musical spell, *listening* to the sound of *silence*. "I like it when there's silence at the end," Evelyn solemnly explains, "because it lets the audience hear what I hear. I don't *deliberately* create it. I just want space to breathe and reflect on the experience of the music." At the tender age of 23; she is an extraordinary musician—a musician who

happens to be deaf.

Despite her youth, Evelyn is an accomplished performer with an Honors Degree from the Royal Academy of Music in London and numerous awards to her credit. She speaks in a lilting Scottish accent that is as expressive as her musical performances. A deft lip reader, she carries on conversations with people who are not even aware of her silent handicap. But as Evelyn emphasizes, she is a musician trying to earn a living performing and perfecting her craft.

Evelyn was born near Aberdeen, Scotland, the youngest child and only daughter of farming parents. She began studying the piano at the age of eight, and two years later she began to play the clarinet. Around that time, her hearing, which she began to lose when she was six years old, went

downhill. "I was very ambitious when I played the clarinet," explains Evelyn, "and I was trying things that were really much too hard for me at the time. I was trying to get the very high notes, and there was a lot of pressure in my head. Therefore, my parents thought that the clarinet was destroying my hearing. They asked me if I would try something else. I happened to see a local girl play the xylophone quite magnificently, and I wanted to do that, too."

At the age of 12, Evelyn entered secondary school and expressed an interest in playing percussion. As did all new pupils, she had to take an aural musical test by answering questions in response to a tape recording. Not admitting that she was deaf, Evelyn scored only two or three marks out of 100. The music teachers did not want to accept her, but the percussion teacher, Ron Forbes, gave her a chance. "There wasn't anything I really couldn't do," she says, "so they took me on. Soon after that I got my hair cut and they saw my hearing aid. From then on, their attitude changed completely.

"During this time, I was still using hearing aids, but sounds were not clear," Evelyn continues. "I was hearing loud sounds but I wanted to hear everything—music, speech, cars, birds, etc. I wasn't interested in feel, and I didn't know about vibrations, so therefore I played extremely loudly in order to hear myself. I would turn the record player and television up as loud as I could and I would talk in a very loud, monotonous, high-pitched voice. I was losing my coordination as far as playing was concerned, and I was losing all sense of dynamics as well, even though I had been a very sensitive piano player. My balance, too, was affected when traveling down escalators or lifts, or even while swimming.

"This was a very frustrating period for me, not just in music, but in everything. I was angry with my family and not coping in the classroom. I was always in a bad mood, and this was rather unlike me. Fortunately, Ron Forbes was such a sensitive person, and he had a great deal of patience with me.

"We were on the challenge of timpani tuning. I just could *not* do it!" She shakes her head back and forth. "Since I have perfect pitch, I knew exactly what I wanted to tune them to, but I couldn't hear them. One day he had me stand outside the percussion room and put my hands flat on the wall. He then tuned the two timpani to a wide interval and asked me which drum he was playing on, the higher or the lower. Then he asked, 'How do you know? Where are you feeling that?' I could feel the vibrations in my hands and lower parts of my

Glennie

by Lauren Vogel

legs, so I got the pitch that way. Gradually the interval became closer and closer, and I could not only tell which drum was being played, but what the interval was.

"When tuning timpani, I lower the drum completely and start from the bottom, slowly working my way up. I also learned the ranges of a particular drum; I know that pressing the pedal so much puts me in the F to A range, or screwing the taps a certain amount of times puts me in the same region. Then I strike the drum and put the shaft of the stick on the timpani head, which tells me how many times the stick vibrates and whether it's a high or low note for the particular drum. I can also put my fingertips on the edge and feel it that way. Of course, you can always feel the sound in the lower part of your body. Now I find it useful to put my cheek on the edge of the skin and feel the vibrations that way. There are countless ways of really hearing a particular instrument."

The next few years were spent performing in a National Youth Orchestra and a regional percussion ensemble. Evelyn fondly remembers, "We were playing some *splendid* pieces, arranged and composed by Ron Forbes. This group was a great success, and it made me realize that I didn't really want to be an orchestral player but instead a multi-percussionist specializing in solo and chamber ensemble music. I realized there was a lot of music that could be arranged for tuned percussion, which was a challenge. So I did quite a bit of arranging while at school."

Eventually, Evelyn realized that, if she were going to carve out a career in music, she needed to go to London. So at the age of 16, she left home to live and learn in London, over 500 miles from her home in Scotland.

She auditioned for both the Royal Academy of Music and the Royal College of Music. She was accepted by *both* schools, but chose the Academy (RAM).

"I studied with Nicholas Cole, who is the principal percussionist with the Royal Philharmonic Orchestra in London," she says. "We got along fine, and I learned so much of the orchestral repertoire. And of course I had the odd lesson with James Blades." Her face lights up as she speaks of the man who has become her mentor and friend.

"I love going over to his house to play snare drum or xylophone duets with him. It keeps him going, especially at his age [88]. I feel very happy to play along with him but—by George!—does he know when you've slipped off of it!

"He's just a gold mine of percussion

knowledge," Evelyn continues. "If I have a query all I have to do is ask, and my answer is there—often not just one answer, either. But the biggest thing he's taught me is just the sheer pleasure of performing. And not just performing, but total communication. That comes down to performing works that *you* enjoy while still being aware of what the audience wants. There's a little saying: 'Know your stuff, know who you're going to stuff, then stuff them!'"

James Blades encouraged her to explore new areas of percussion. Evelyn spent some time in Switzerland studying jazz vibraphone with Rud Weiner and marimba with Peter Prommel. "It was a great time for me," she exclaims. "I had been getting a bit down as far as technique was concerned, and there wasn't anyone in our country to show me what I wanted to know. There were so many things I hadn't seen before or been aware of. When I got back to London I went straight home to my marimba and tried out all the things I had learned. I discovered I could actually do things in a matter of minutes that I had been trying to do for weeks and months on end because I'd been shown different things about holding four mallets." Evelyn reaches for some mallets to demonstrate. Her grip is a cross between the traditional four-mallet grip and the Burton grip; the sticks cross over between the second and third finger, though further down the finger. "I find that I can get a lot of independence and stretch this way. I've tried other grips, but it would take me a long time to learn them, and I think it's too late as far as my career is concerned. But this works for me!"

Evelyn also traveled to Japan to study marimba with Keiko Abe. "That really was an experience I'd like to repeat again," she recalls. "It was so wonderful. The lessons were full of energy and so full of space as well—just to think. We played together, we improvised together, we did so many things. It was full of communication."

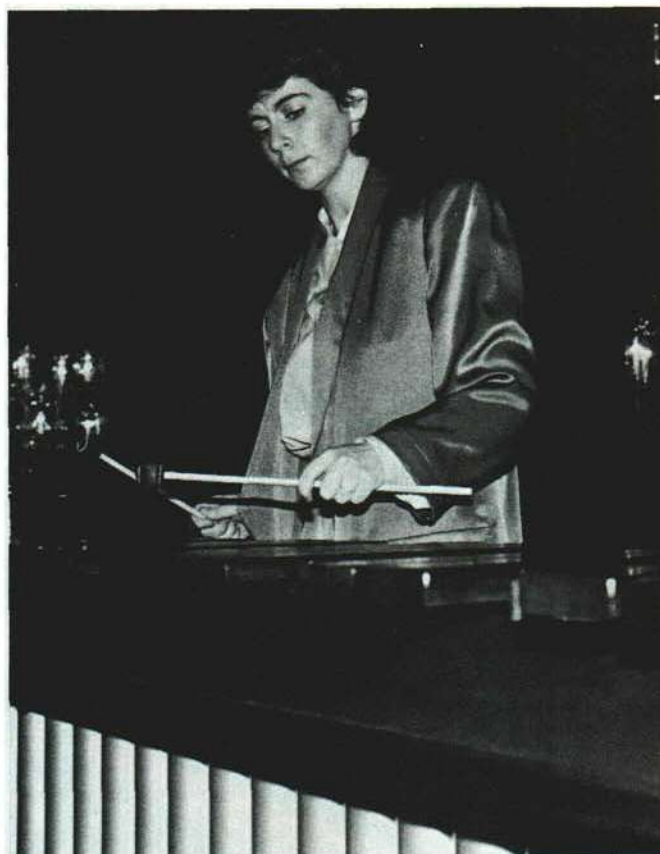

Photo by Lissa Wales

In 1984, during her second year at the Academy, Evelyn entered a national percussion competition and won the Gold Medal (plus £3,000) in the Shell/London Symphony Orchestra Music Scholarship. One of the biggest advantages of the competition for 18-year-old Evelyn was the contacts that she made. "I got to know all the LSO percussionists," she explains. "And I took some lessons from Kurt Goedecke, the timpanist. His approach is very German and strict, unlike, for example, Keiko, who is more free but still strict and disciplined."

Besides the Shell/LSO Scholarship, Evelyn received the James Blades Prize twice—one year for timpani and the following year for percussion. She is also the recipient of the Hugh Fitch Prize for percussion and the Hilda Deane Anderson Prize for orchestral playing. Perhaps the most important acknowledgement from the Royal Academy of Music was the Queen's Commendation Prize for all-around excellence—the highest award given by the RAM to the best student in both performance and academics. In 1987, Evelyn won the Leonardo da Vinci prize for the most outstanding young musician as selected by eight European Rotary Clubs. Early in 1988, she also became an Associate of the Royal Academy of Music. Evelyn has also had numerous recital pieces written for her—for percussion and piano, for percussion and trumpet

(featuring John Wallace, principal trumpet in the Philharmonia), for percussion and accordion, two percussion concertos, and a piece by top session/jazz musician Ray Russell for marimba, trumpet, drums, piano, bass, and guitar. She plans to perform the latter on one of her first records.

In 1984, Evelyn was the subject of a BBC television documentary entitled *A Will To Win*. It was a series of six programs, each one profiling a person who had a specific aim in life. "My aim was to be a professional musician," states Evelyn. "My program was the first one in the series, and it was basically about my childhood, my education at the Academy, and my performances. This exposure got me a lot of solo

work outside the Academy."

Following *A Will To Win*, Yorkshire TV produced another documentary entitled *Good Vibrations*. The second one was less about Evelyn's upbringing and more about her percussion playing, along with the medical side to deafness and music.

Evelyn has also been associated with the Beethoven Fund for Deaf Children, which provides musical instruments for the schools for the deaf. One would not expect a school for the deaf to need musical instruments, but it does. "Not only does it help their speech, but it lets out their frustration and aggravation while helping their coordination," Evelyn explains. "Many deaf schools in Britain use tone bars, which are individ-

ual marimba bars on a big wooden box. The children hold this wooden box, strike the note, and try to match the vibrations from this note onto their voice box. With several notes, you can get the feeling of accents, rhythms, and intonations. For example, 'hello' could be a third.

"With percussion," she continues, "there are so many instruments to deal with, each producing different vibrations and sensations. I can relate them to my voice. The same weight that you use to play *fortissimo* on timpani does not work on a glockenspiel. I can relate this to speech; I talk loudly in a reception room following a concert and more softly in a normal conversation with one person." How does she know the correct volume level to speak if she can not hear herself? "If I put my hand on my neck while I talk, I can feel the vibrations."

Evelyn stopped wearing hearing aids by the time she was 16. "I found it distracting in that it boosts the sound but doesn't make anything any clearer. I would hear bits of sounds but not know where they were coming from. Speech is totally lost, but sometimes I can get the *impact* of the xylophone or the *impact* of a drum. The marimba is the hardest of all because it's mellower, but it is the instrument that I really like to delve into.

"Music is the sort of business where you are surrounded by hearing people, and you have to accept that," she adds matter-of-factly. "I don't pursue sign language because I can lip read and because I'm surrounded all the time by people who don't even know that I'm deaf." This fact is intentionally omitted from her publicity bio because Evelyn wants the respect of being a *musician*, not a deaf one. Despite the fact that some of her audience may come to see a "spectacle," most leave with a deeper appreciation of her art.

One of Evelyn's recital pieces is Saint-Saens' *Introduction And Rondo Capriccioso*, played on marimba. Although she has never heard the piece, she performs it more musically and expressively than many a talented violinist. "I think it's part of *being* a musician," Evelyn explains. "If you were given a piece of music that hadn't been recorded, or you hadn't heard it in some way, you would feel confident enough as a musician to create your own interpretation. My opening [the slow section] would probably be very different compared to what a violin player would do. When I play the Saint-Saens on marimba, I regard it as a marimba piece. When it's played on the violin, it's a violin piece. I keep them separate, as opposed to thinking of it as a violin transcription. That's the biggest thing: to play a piece as though it was written for your instrument. I do this all the time, and the pieces work better if I think of them as marimba pieces.

"Everything I play is entirely my own interpretation. I don't listen to records or tapes as such, so I've got to rely on something, and it might as well be my inner feeling for a piece—unless I want to learn it

**Look good, Play good...
Period!**

DURATECH™
MUSIC PRODUCTS
P.O. Box 846
Thomasville, NC 27361
Ask for Duratech Drumsticks at your local dealer.
Photo by: R. Truell

in a parrot fashion from someone else, which I *don't* believe is a good idea.

"If I put on a record, then it's someone else playing it," she continues. "It's like an accent. When I was born, I picked up a Scottish Averbondian accent because that was the first thing I heard. Likewise, when you first hear someone performing a piece, *that's* the initial interpretation that you get, and you'll always remember and be influenced by that, even though you play it your own way later on. That memory is still there, like the accent that your mother spoke to you in. I just find that I'm totally Evelyn when I play."

So how does she go about interpreting a new piece? "I'm inclined to exaggerate the dynamics," she answers. "Take the end of *Michi* for example. I want it to be as quiet as possible, to be just nothing. I can do it because I know the capabilities of a marimba. And it's also an inner feeling—a feel for the sound, the range of notes, and even the music itself.

"I also experiment with interpretations by playing differently in each performance. The difficulty lies in knowing the acoustics of the hall, because it determines which sticks I use. That's when I need someone to tell me, because sometimes I play too soft for a particular place and no one can hear me, or sometimes I play too loudly, so I need someone to tell me that."

Evelyn is also a very visual performer. "The audience can see the instrument and the sticks, so they can hear the sound even before I strike the note. It makes people listen. Even if you're not playing a note, they think you are because they can see you."

Returning to the Saint-Saens, Evelyn's interpretation of the slow introduction is different than most marimbists'. Instead of rolling the slow 8th notes, she just plays them—"slurring" the sound from a louder attack to a softer release. "I've tried rolling it," she explains. "Even violin players have suggested I roll it. Somehow, I'm not convinced of that way. I don't like the rhythmic sound." To demonstrate, she trills her tongue while singing the melody. "I just feel that by the expression and weight that you use, you can get that slur by striking two simple notes. BA-A-A-A [loud] bum [soft]. You can just feel it. Also, the slight resonance on a marimba will give you the sustain rather than making an unnatural sustain by rolling it."

As slow as the "Introduction" is, the final page of the "Rondo" is a blur of running 16th notes. To avoid hitting wrong notes, Evelyn is constantly watching the keyboard. "It's not difficult at all. I'm very visually aware, in that I do a lot of slow practice where I really look at what I'm doing. You can *feel* where your hand is going—the space. Something like the bottom B in *Michi*—you know where it is by feel. I wouldn't be able to tell if I was playing it correctly or not if I wasn't looking. But you look at the left hand and not the right hand, because the right hand is much easier. In

the Saint-Saens, I make a point of accenting the bottom A, so I spring from there and just glide all the way up—not looking at every individual note, because you obviously have to rely on your technique. Likewise, with all the scales I play, I spring from one note at the top to the bottom. I don't care what happens in between, as long as I get from A to B and back to A again."

Besides being an accomplished soloist, Evelyn performs many pieces (like the Saint-Saens) with a regular accompanist. Even a pianist she met only hours before a performance did "a jolly good job considering the short time he had the music!" Evelyn laughs as she recalls a concert. "But any-

way, I always play the piano accompaniment part myself. That's the beauty of being able to play the piano. Then I can understand exactly what the pianist's part is about.

"Also notice how I have the piano positioned. I make a point of seeing the pianist's face, as much of the keyboard as possible, the foot pedal—which is *very* important—and the inside of the piano if it's a grand. When I'm waiting to come in, I watch the pianist playing because he may speed up or slow down or something. That's why a performance is not just playing; it's the general presentation and interaction between the musicians—and the audience. I may look at the pianist as though I am totally involved in what he's doing—which

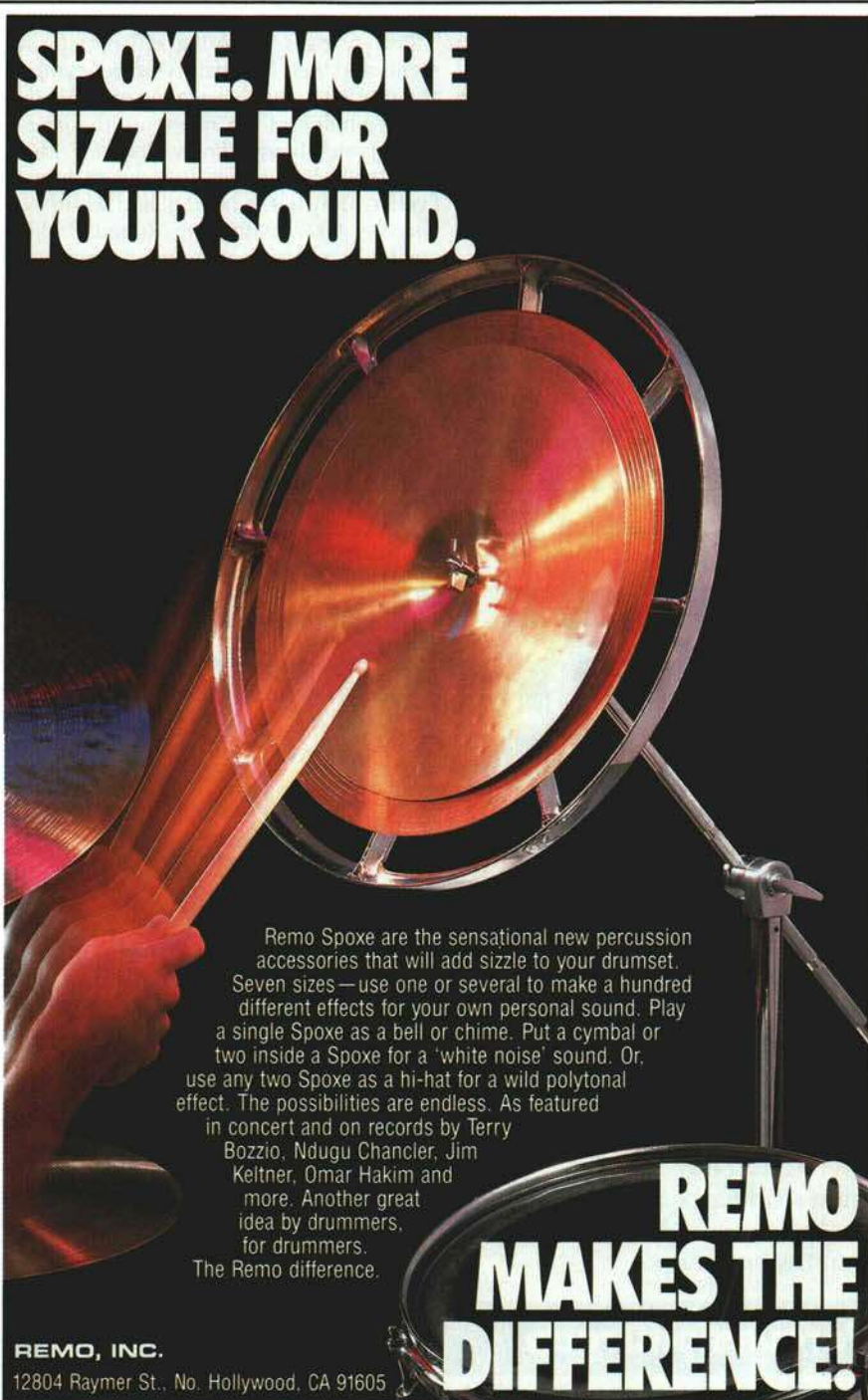

**SPOXE. MORE
SIZZLE FOR
YOUR SOUND.**

Remo Spoxe are the sensational new percussion accessories that will add sizzle to your drumset. Seven sizes—use one or several to make a hundred different effects for your own personal sound. Play a single Spoxe as a bell or chime. Put a cymbal or two inside a Spoxe for a 'white noise' sound. Or, use any two Spoxe as a hi-hat for a wild polytonal effect. The possibilities are endless. As featured in concert and on records by Terry Bozzio, Ndugu Chancler, Jim Keltner, Omar Hakim and more. Another great idea by drummers, for drummers.

The Remo difference.

**REMO
MAKES THE
DIFFERENCE!**

REMO, INC.
12804 Raymer St., No. Hollywood, CA 91605

in fact I am—but I'm also looking to see just where he is in the music! Actually, it's very easy to do because the biggest part is knowing the whole piece well."

She applies the same theory when she performs as an orchestral percussionist. "I always read my part from a full score so that I'm reading vertically as opposed to horizontally," she says. "I know exactly who is playing with me, and I know the texture of the music. If the score is marked *pianissimo* with the strings *pizzicato*, then I know that I'm not going to strike whatever I'm playing very loudly unless I'm a solo or a prominent part. And I *always* watch the conductor."

What does she do when she must express herself through a new instrument that she has never heard? "Perhaps my biggest problem is not always knowing what instruments sound like, and that's when you

depend on other people to give you as accurate a description as possible. Like Ed Thigpen," Evelyn recalls with a smile. "We were at the PAS convention in St. Louis, and we were both looking at a new Latin percussion book that came with three tapes. I asked the gentleman at the booth if the book would be an advantage to me without the tapes. That's when Ed came along and said I *could* use the book.

"We came across a guiro part, and Ed took my fingernail and rubbed it over a rough surface, almost like sandpaper, and went shhhhh-da-da-shhhhh-da-da." Evelyn quite accurately mimics the sound of a guiro. "That's how I would like sound related to me, by part of my body. Vibrations are part of my body, and this is just a slightly different angle."

Evelyn loves exploring different instruments and their sounds. Trying out cymbals at a music fair at Olympia in London led to the beginning of her relationship with Sabian. James Blades knew Robert Zildjian very well, and Blades introduced him to Evelyn. They got to talking, and while Evelyn was taken with both Robert Zildjian and his cymbals, he was equally impressed with her as a performer. Evelyn soon became a Sabian clinician and presented her first performance in America at the PAS convention in Los Angeles in 1985.

"I used to not know a good cymbal from a very good cymbal," Evelyn says. "But Robert Zildjian got someone at the factory

to pick out the very best cymbals for me. I can somehow tell the different texture. I can feel it."

Although she likes cymbals, when asked to pick her favorite percussion instrument, Evelyn pleads, "Can I choose two? Please?!" She narrows it down to marimba and snare drum. "I like the marimba because it's such an expressive instrument, and there's a lot of music written for it. It's got a better range than a xylophone and makes a wonderful solo instrument. I also like the snare drum as a solo instrument and in a band texture. It can sound like velvet or bullets. Do I get to add that I also like timpani in an orchestra?"

In June of 1987, Evelyn performed Bartok's *Sonata For Two Pianos And Percussion* with Sir George Solti, Murray Perahia, and David Corkhill in London, Paris, Germany, and Zurich. She has also recently signed a recording contract with RCA. She is a very accomplished musician who has a great deal of artistry inside her to share. Her performances speak directly to her audience, and even her conversation is rich with descriptive emotion. It is difficult for words on paper to capture her unique spirit.

"You can only realize what your capabilities are if you give yourself a goal and a chance, and to actually have faith in yourself—in your gift or talent. You must be 100% involved in your music but not be oblivious to everything else. You must be aware of what's happening around you—aware of life, of people, of everyday news, of art, of poetry, of writing, of everything—because this makes you a complete person.

"Advice is very difficult to give," she continues. "Everyone tells a young player to practice and work hard, and by all means, yes, you really need to do that. But practice sessions should not be a chore. It really must be constructive rather than a feeling of having to practice for five or eight hours. You may be able to do something in five minutes that you might try doing over several hours. If you've done that in five minutes, great! Don't feel that you've got to fulfill the other seven hours 55 minutes just for the sake of it. It's the *quality*."

Evelyn Glennie plans to continue performing both recitals and concertos. Her recording career will also begin to take up more time. Although she does not teach at present, she hopes one day to have time for some private pupils. Evelyn does give a lot of master classes, workshops, clinics, and lecture/recitals to people of all ages—musicians and non-musicians alike. She presents her talk/recitals from music colleges in Britain to prisons—which is a real experience!

"This is a very exciting time in my life," Evelyn admits. "There are so many things I want to do. As long as the performing aspect keeps going, I'll go along with it and we'll see where it takes me." She winks and smiles and says, in her lilting Scottish accent, "I'd love to travel and just explore the world of percussion."

CHESTER THOMPSON

in clinic

April 2, 1989

call for info

DRUMSTIX
3605 Miller Rd.
Wilm., DE 19802
302-762-1075

Two of the most sensitive, articulate performers in the business.

Peter Erskine and the Beyer M422 share many of the same qualities. Dedication to detail. An appreciation for subtlety. Qualities that make the difference between good music, and great music.

You'll find these same characteristics in every PercussionGroup mic. From the M 380 bass drum mic, to the M 420 for toms, to the M 713 condenser for overheads. So go with the most sensitive performers in the business. Beyer PercussionGroup.

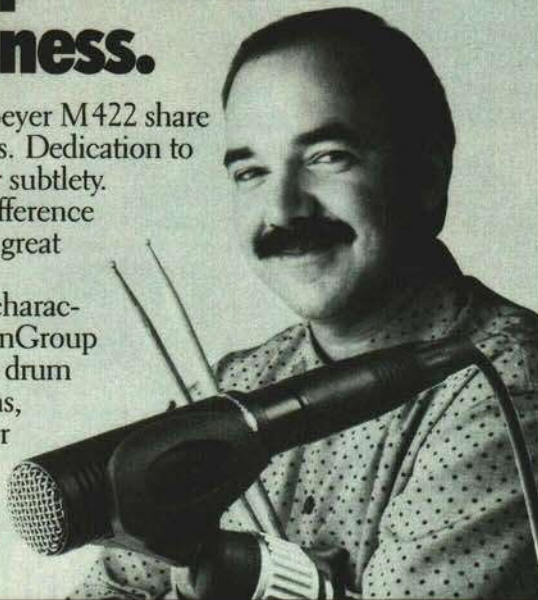

PercussionGroup

beyerdynamic |||||

©beyerdynamic 1989

5-05 Burns Avenue, Hicksville, NY 11801
Tel. (516) 935-8000. Fax (516) 935-8018



Gibraltar

H A R D W A R E

On Tour with Dony Wynn
and the Robert Palmer Band

When a pro like Dony Wynn makes a world tour he wants the finest hardware, that's why he chooses Gibraltar.

Whether you're setting up once a day or once a week, it makes sense to connect with quality-built Gibraltar Hardware. Take a look at the complete line of Gibraltar 7000, 9000 and Power Rack Systems and the all new line of Gibraltar Service Center parts at your local drum shop.

Gibraltar 9000 Series Stands

For more information write to:
Gibraltar
c/o Kaman Percussion Team
Kaman Music Corporation
P.O. Box 507
Bloomfield, CT 06002

KAMAN

Photo by Ebet Roberts



and sound into it, which I always wanted to do. When people heard me or the records that I'm on, they knew it was me. If they didn't know me by my name live, they knew when they heard me every time they came to see those shows. "Who's that drummer? It's got to be the same drummer they had a year or two years ago. He sounds the same; he has a certain feel."

RT: How did you make the switch from P-Funk into the jazz world?

DC: The jazz world is what I was into before I joined P-Funk, so that was simple. I grew up playing fusion and bebop, even though my bebop chops right now are really rusty. There are things that I wish I could do that I used to do but just can't anymore, because I haven't sat down and

worked those rhythms out. At one time I used to get called for bebop gigs, and that's all I did. But for the last three years, and even longer with P-Funk—I was in that band for nine years—all I did was play P-Funk. If you know how to play fusion music and then you play funk music, you can always go back and not lose too much. But jazz is totally different. If you don't stay up on the bebop rhythms, you definitely lose them.

RT: Did you keep up your connections to the jazz world while you were in P-Funk?

DC: No. Surprisingly enough, between 1983 and '85, we were getting such a reputation, all the musicians would come up to see us. It was nothing to be on a P-Funk gig in L.A., and look around, and there would be Lenny White, Stanley Clarke, George Duke, or a few of the jazz musicians like Herbie Hancock, Wayne Shorter, or Freddie Hubbard. And the ones who didn't see the band knew about it. So when that band broke up, I wound up in New York doing sessions. The wild thing that happened with John Scofield is that Gary Grainger was in the band, and he told John about me. When John was with Miles Davis, the drummer in that band would play nothing but live tapes of P-Funk. He heard that stuff and dug the way I played. Scofield's band went to San Francisco, and I was playing with Special EFX at the same place John was playing the next night. Gary dragged him out of the room to hear me play, and John just dug it. He asked if I would do an album project

with him, which was *Blue Matter*. I was busy for a while, then I saw him in Switzerland, and he said, "Man, when are you going to join my band?" When I came home I called him and told him we could start working on some things. At that time, the band was Mitch Forman, Gary Grainger, Hiram Bullock as an added extra rhythm guitar player, and John. We did two weeks of gigs before we went into the studio to cut the album. And right after the album we hit it. John wanted me to come in and finish out the tour, which was fun.

RT: It really sounds like a *band*. There's a good feeling.

DC: Yeah, you have to hear it live. It's totally different from the records—a lot better. As a matter of fact, when we did those records, we had to find ways to cut back on it, because we got so used to playing real strange odd rhythms, and the energy was so high. It would scare people if you put a record on that had the kind of energy that we were used to playing with. We would stretch a hell of a lot more live, taking chances with different rhythms.

RT: You did two albums with Special EFX. How was that music different from Scofield's?

DC: Man, it was a lot different. John's music has a lot more energy and is a lot more involved. In Special EFX's music, the drum chair is not that important, except when Dave Weckl plays. They let Dave Weckl be Dave Weckl on the albums, but when I was playing with them it wasn't the same way.

KELLY, MIKE, DEEN AND GLENN. AND SABIAN. HEAR THE DIFFERENCE.

Photographed in LA by Chris Cullaro for Sabian.

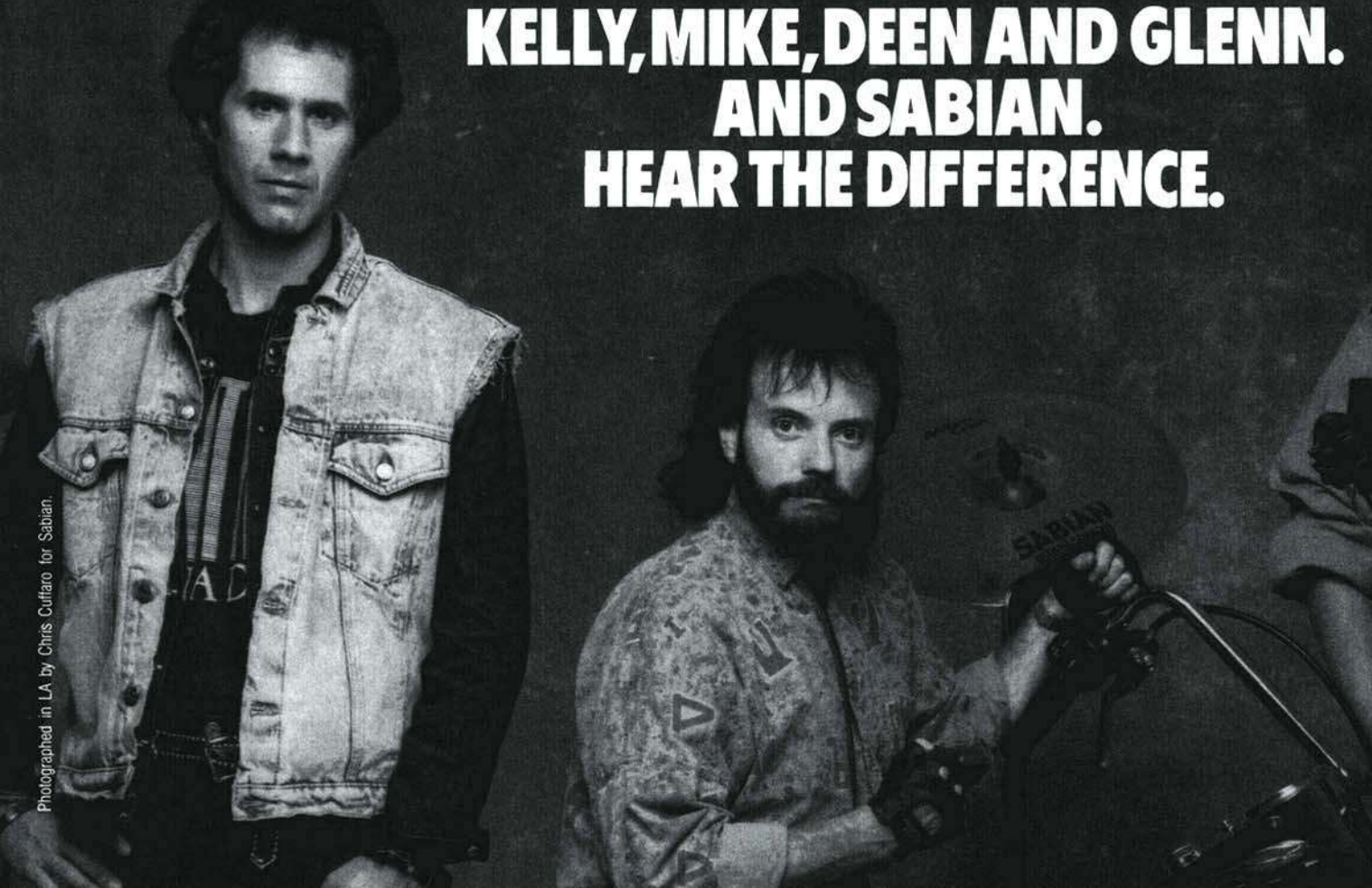

They were constantly telling me what to play, what not to play. And strangely enough, when they hear one of the John Scofield albums now, they feel a little bit left out. They had an opportunity to let me do my thing with them but they didn't. When I was playing with them, it was always the guitar player and the percussionist. They've got a great drummer now named Rodney Holmes, and Vince Lovings, a monster bass player from New York.

RT: Do you enjoy molding yourself to what somebody else is doing, or would you rather be Dennis Chambers?
DC: I do find it a challenge to try to play what somebody else played. But by the same token, when it comes to doing albums, I'd rather get my own identity across. When you first join a band and the drummer before you played some nice things, you learn those things and try to play exactly what he did, and at the same time put your own little things in there. That's all part of playing the music. But when it comes to the point of doing the albums, there should be a cross period where the band should sound a little different, because now you're putting *your* identity into the thing. With John, when I played gigs before the *Blue Matter* album came out, I played all the stuff that Omar and Steve Jordan had done the same way they would normally play that music, and I added my own little things into it. When we did the album date, it was time for me to do my own thing. When we did gigs after that album came

out, then it was like my style, my way of approaching music.

RT: You do some real nice double-time work on the hi-hat, some fast syncopation stuff.

DC: I know what you're talking about. I don't know where it came from. All that hi-hat stuff that the Meters would do, which was never heard of until Ziggy Modeliste did the thing, all of a sudden everybody was copying. Everybody was trying to play like Ziggy. So I figured there must be something more to doing hi-hat things than playing dat-dat sst-sst. Then sure enough, Pretty Purdie came up and did "Rock Steady" with Aretha, and did some sweet things on the hi-hat. Then for a long period of time I just concentrated on trying to get a certain technique on the hi-hat, where I could do rudiments on it and make it sound musical. I'd do some weird patterns with double-stroke rolls on the hi-hat, and keeping 2 and 4 going on the snare drum, or syncopating certain things on the hi-hat. Instead of playing with my right hand, I would play with my left hand, because you get a different feel than you would with your right hand. Each hand has a personal identity.

RT: Gadd's beat on "50 Ways To Leave Your Lover" of course comes to mind.

DC: Right. That's a perfect example of what Gadd did with his left hand. Things he did with his left hand are totally ridiculous. But the reason he did what he did is because of the feel. It just feels different when you're

playing something with your left hand. He can play that same beat with his right hand and it'd sound like a normal thing.

RT: You play both traditional and matched grip.

DC: I play traditional and matched, and I can lead with my right or my left hand.

RT: Did you have to work on that, or are you naturally ambidextrous?

DC: I've worked on being ambidextrous. At one time I was real good at it, and that's what led me to play timbales and everything—grabbing cymbals and hitting cowbells and all that stuff. When people saw that, they couldn't tell if I was right-handed or left-handed, and they didn't know which hand was going to hit that snare drum sometimes. One minute I'd be playing all this flashy stuff with my left hand on the snare drum, and then I'd be back real fast the next minute doing something else on the bell of the cymbal, and keeping the hi-hat going with my foot. I only play the hi-hat with the stick on certain grooves. There are a lot of grooves where I just play the hi-hat with my foot, so my hands are free to do other things.

RT: Some of my favorite moments in your set with Michael Brecker were when just you and Michael were jamming together.

DC: Yeah, I love playing when it's just me and the saxophonist. But the thing about Michael's music is that I haven't done this kind of playing in years, where some sort of bebop or jazz thing is involved. But it was a challenge for me. I wanted to see if I

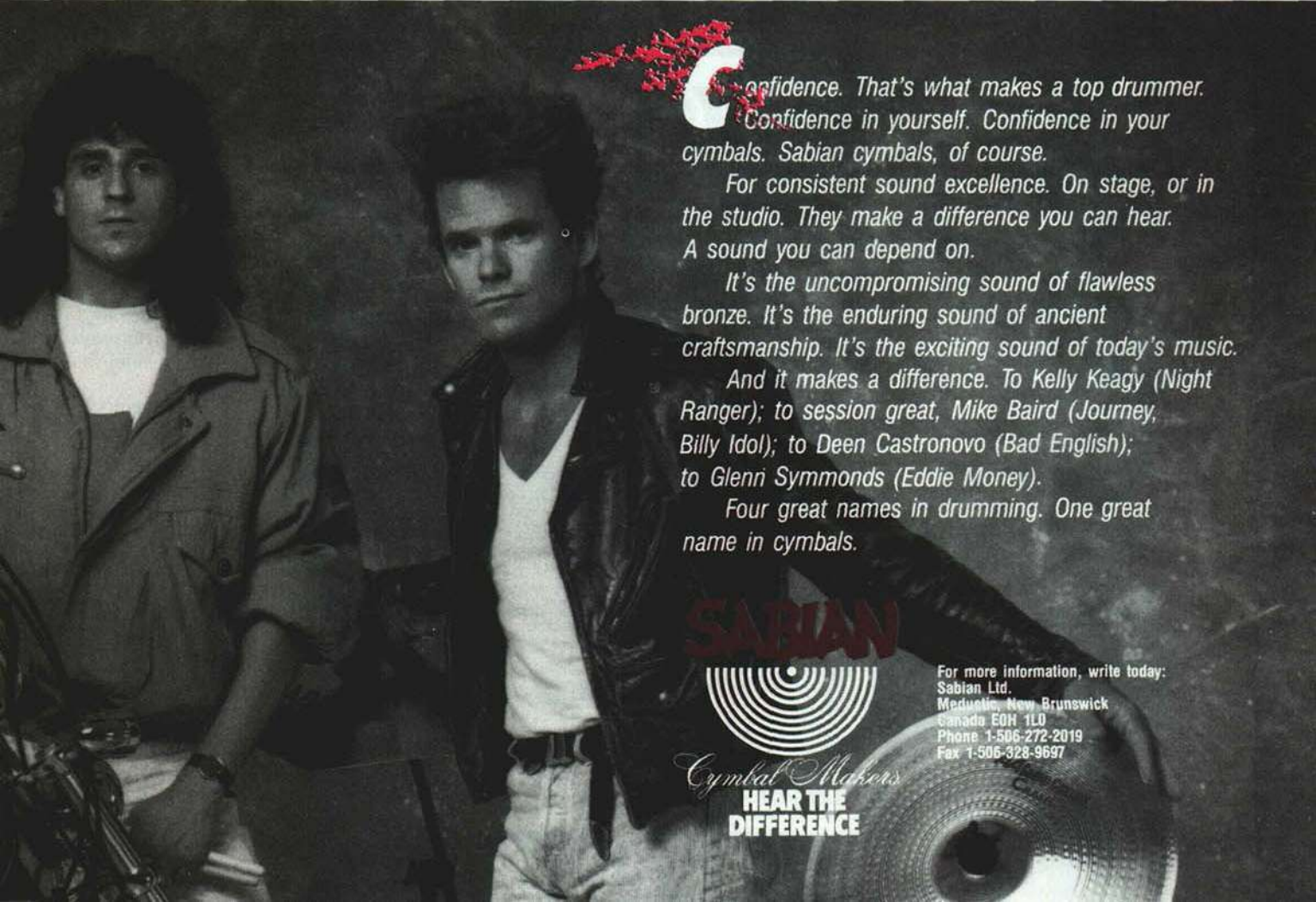

Confidence. That's what makes a top drummer.
Confidence in yourself. Confidence in your cymbals. Sabian cymbals, of course.

For consistent sound excellence. On stage, or in the studio. They make a difference you can hear. A sound you can depend on.

It's the uncompromising sound of flawless bronze. It's the enduring sound of ancient craftsmanship. It's the exciting sound of today's music.

And it makes a difference. To Kelly Keagy (*Night Ranger*); to session great, Mike Baird (*Journey*, *Billy Idol*); to Deen Castronovo (*Bad English*); to Glenn Symmonds (*Eddie Money*).

Four great names in drumming. One great name in cymbals.



Cymbal Makers
HEAR THE DIFFERENCE

For more information, write today:
Sabian Ltd.
Meductic, New Brunswick
Canada E0H 1L0
Phone 1-506-272-2019
Fax 1-506-328-9697

FEEL the POWER of CONTROL



drumKAT MIDI CONTROLLER

- ▲ 10 ZONEABLE PADS
- ▲ VELOCITY SENSITIVE
- ▲ 2 MIDI INS / 4 MIDI OUTS
- ▲ 9 TRIGGER INS
- ▲ BUILT-IN SEQUENCER

FOR FREE BROCHURE CONTACT:
 SALES: 172 WASHINGTON AVE., DEPT. D, W. HEMPSTEAD, NY 11552
 (516) 481-3004 FAX (516) 481-8487
 MAIN OFFICE: P. O. BOX 48607, LONGMEADOW, MA 01116
 (413) 587-1395



KAT MIDI CONTROLLERS

could "swing" the band. And the show had its moments. Michael's always coming off-stage smiling and talking to me about what I played. I get the feeling that he likes what I'm doing. But there's a doubt in my mind that maybe this didn't sound too good, because I'm used to hearing what I used to do. When Mark [Mondesir, with Courtney Pine] plays, he really swings. He has the understanding of swing, and you can hear it in his playing. I was sort of the same way when I used to play swing. But my thing now is playing fusion and funk.

RT: When you were with Parliament, did you learn anything about the showmanship angle of things?

DC: They had fired their percussionist and wanted me to play timbales. They thought it was real cute to have one drummer back there playing all this crazy stuff. That was the showmanship part. I'd throw sticks up and catch them behind my back; I used to do a lot of stuff, spinning the sticks in solos, and doing the cross rhythms with the bass drum and the cymbals. I used to do that with one bass drum. Now I can do it with two in order to get it across. But one time I did it with one bass drum pedal.

RT: You have a great right foot.

DC: When I was growing up and learning drums I heard double bass drums. I couldn't afford them, so I tried to play double bass drum licks with one foot. Sometimes it worked and sometimes it didn't. My right foot is a lot stronger, because I would do hand and feet combinations. Instead of doing a Paradiddle with the right and left hand, I would do it with the left and right foot. I would do double-stroke rolls with the left hand and the right foot, and then alternate with the right hand and left foot on hi-hat.

RT: I'm hearing more drummers applying some beat to a part of the kit that you wouldn't expect, like what Gadd did on the hi-hat with his left hand.

DC: There's another thing I do with the left hand. What I do on hi-hat—the triplets and all that—I'll keep that going, and also play the backbeat and whatever else I'm doing on the snare drum. I'll play rhythms on the bell of the cymbal with my left hand. People ask me what the hell that is.

RT: Keeping your right hand going back and forth between hi-hat and snare?

DC: Yeah, because the right hand is playing ghost notes, multiple bounces. And my left hand is playing the bell. And then I'm playing the backbeat with the right hand, too. When people see it, it looks weird, because I'm not doing the normal things with my right hand. I'm not over there on a ride cymbal. If you play lead with your right hand, you're playing over the top like this and your left hand is helping on the hi-hat and going back to the snare drum. It sounds great and it's got a groove. But when you do it this other way, it's a totally different groove. It's a challenge to make things sound different, and still strong.

Just When You Thought It Was Safe ... The SHARK is back.



The original electronic trigger pedal. Now faster, more accurate and deadlier than ever. Ergonomically efficient pedal action combined with an exclusive *Dynatuned* trigger sensor for absolutely perfect triggering of electronic drum sounds and effects.

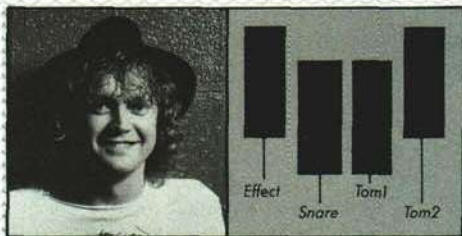

Rick Allen (Def Leppard) and his Sharks

Catch a Shark at your nearest drum dealer or contact:

THE SHARK

Group Centre Inc.
 751 South Kellogg, Ste. A
 Goleta, CA 93117
 805-683-3340



Omar Hakim's No. 1 Picco.

If you could hear Omar Hakim talking about his choice of snare drums, you'd be listening to a testimonial on the Pearl 3½"x14" Free Floating System Brass Piccolo. Omar discussed its unique sensitivity, its great projection and tonal properties, its exclusive "no hardware touching the shell" design and the rugged die-cast hoops and super smooth S-011E Strainer, before deciding that one picture is worth a thousand words (see photo 4).



B-914P Brass Shell Piccolo



G-914P Maple Shell Piccolo

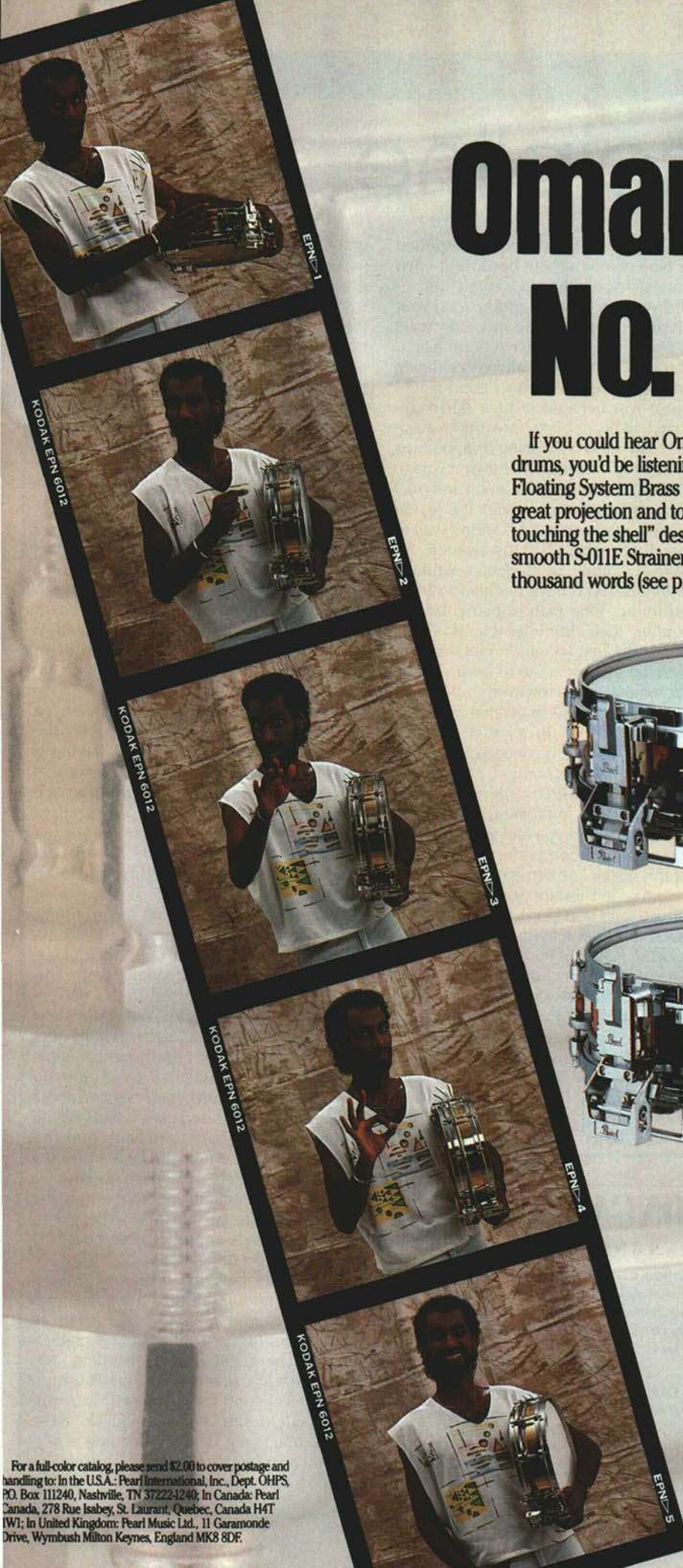

For a full-color catalog, please send \$2.00 to cover postage and handling to: In the U.S.A.: Pearl International, Inc., Dept. OHPS, P.O. Box 111240, Nashville, TN 37222-1240; In Canada: Pearl Canada, 278 Rue Isabey, St. Laurent, Quebec, Canada H4T 1W1; In United Kingdom: Pearl Music Ltd., 11 Garamonde Drive, Wymbush Milton Keynes, England MK8 8DF.

Pearl.

The Best Reason To Play Drums

Discipline

by Roy Burns

Ever since I was young, I have always enjoyed practicing. I think one of the reasons for this is that my parents left it to me to decide when and how much to practice. My father had only one rule: "No practicing on Sunday!" I actually liked this rule because it gave me one day to relax, go to the movies, or hang out with friends. My parents encouraged me, but they never attempted to regulate my practicing. To me, the best form of discipline is self-discipline, because it is a result of doing something you love to do.

One of the reasons that practicing was fun was because it was creative. My practicing was based on whatever I was really interested in at the time. When I was taking lessons, I practiced the lesson first and then rewarded myself with a creative session on the drumset.

Another type of discipline is military-style discipline, which is imposed on you by someone else. Working for the old big band leaders was similar to this in many ways. Although it helps you to learn to deal with pressure, this sort of discipline has its limi-

tations. You can easily become dispirited in this type of atmosphere because it often becomes stale quickly and is rarely fun.

Self-discipline is a by-product of your own desire to do something you really want to do. I was fortunate to have drum teachers who were all positive and encouraging personalities. They were also good teachers, but it was because of their personalities that I really looked forward to each lesson. I can remember being disappointed when the hour was over. The lesson was so much fun that I wanted it to go on and on. I would usually rush home after the lesson because I was so excited; I couldn't wait to start practicing what I had just learned.

I have a couple of students—working professionals—who have decided to learn to read music. One man in particular is a well-known rock drummer. He was very nervous at the first lesson. In fact, he said, "I never had the discipline to sit down and learn to read music. However, in the work I'm now doing, I need to be able to read."

I pointed out first of all that no great sense of discipline is needed. What *is* needed is desire. Secondly, I pointed out that it could be an enjoyable experience. Any time you are improving, your confidence increases and you feel good—knowing that you are accomplishing something. Out of this desire and sense of accomplishment comes self-discipline. It becomes a part of you, and you begin to use the same approach in other activities, often without really being aware of it.

When I started in business I used the same approach. It was something that I wanted to do, and I knew it would take a lot of work in order to be successful. Again, desire was the catalyst for the self-discipline to study, read, understand, and learn what it was really like to start one's own business.

We have to be careful not to look at

practicing as a "responsibility." When we make practicing a responsibility, we make it a burden, a chore. When a parent says something like, "Look! I'm *paying* for your piano lessons. You will practice for one hour every day at 3:00," almost any young person will be discouraged from playing the piano. It has now become a chore, much like doing homework, or cleaning his or her room.

We all have to be responsible in one way or another. We *do* have to be on time for appointments, lessons, rehearsals, or whatever; we *do* have to keep our agreements and pay our debts. However, you cannot approach playing a musical instrument in this way with much success. Most of the drummers I have met who hate to practice feel this way because they regard it as an obligation. A few lessons with a teacher who has a negative personality or an uninformed approach can often create this hatred of practicing.



One of my students had just such an experience. He was rehearsing with the high school drum section and having a problem reading the particular cadence that they were working on. The drum coach said to him, "You're nothing but a stupid jazz drummer!" Needless to say, a teacher with such a negative attitude can make a student hate teachers, lessons, and even practicing.

In a way, the remark was sort of funny. The young man in question is a good all-around player who performs rock, jazz, fusion, and funk styles equally well. This year he has been accepted to the Berklee College of Music in Boston. Fortunately, his desire to play was such that he was able to overcome this negative experience.

A famous pro basketball coach just retired in mid-season. When questioned about this he said, "I promised myself that I would quit when coaching stopped being fun. This year it has been no fun, and I want to enjoy the life I have left." Needless to say, his players were shocked—not to mention the owner of the team. No one expected it. However, from his point of view, coaching had become an obligation.

I started to play the drums because it was fun. It *should* be fun. But sometimes you have to find ways to *make* it fun. In order to do this, your playing and practicing must be creative and rewarding. You must learn, grow, and improve. You *must* begin to feel good about yourself. You must keep your desire alive. If you do these things, practicing will not become a burden or an obligation, and the discipline will take care of itself.

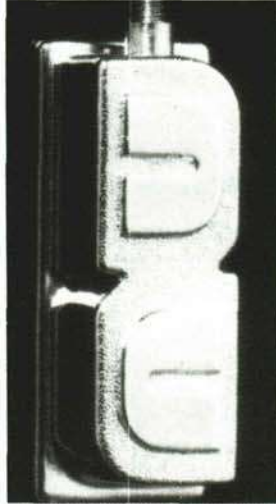
THE LEGACY OF
3E1000 PERCUSSION
UNILUG CONSTRUCTION

DESIGNED & PRODUCED BY DRUM CITY

1-402-397-1060	1-512-656-4785
Joe Voda's Drum City	Kirk Scott's Drum City
602 South 72nd St.	10708 Perrin Beitel
Omaha, NE 68114	San Antonio, TX 78217

CONGA DRUM
LESSONS ON VIDEO



Cuban Drum master Rolando Soto, former percussionist of the internationally famous *Rumbavana Orchestra*, teaches traditional Afro-Cuban rhythms. Ideal for beginners or experienced drummers who want to expand their knowledge.

Beginning Conga Advanced Conga

Send \$39.95 check or International Money Order plus \$3 postage and handling (\$7 outside US) per tape to:

TropiCal Productions
 826 Crestmoore Place, Venice California 90291 USA
 Please allow 3-6 weeks for delivery.



BREAKTHROUGH.

Bass instrument micing is the most difficult in the world. That's a fact. Explosive transients, shattering SPL ratings and low fundamentals constantly obscuring the essential mid and high-frequency overtones... all combine to present the greatest challenge there is to the science and art of microphone design.

AKG has met that challenge with a breakthrough.

The D-112 is *the* mic for bass recording: kick drum, toms, sax, electric bass, leslies. Every part of it, from casing and special bumper-protected windscreens to unique shock suspended dynamic transducer, will take a

beating and still deliver. The D-112 is so distortion free that today's test equipment can't measure it. (Computer analysis we've done indicates virtually zero distortion all the way up to 168 dB!)

Best of all, the D-112 sounds terrific. We've built in emphasis at 100 Hz and 4 kHz, to capture those special frequencies that give a bass track punch. EQ is unnecessary; your sounds will stay clear and clean in the mix.

Like the D-12E, the D-112 is a breakthrough that lets you break through!



77 Selleck Street
Stamford, CT 06902

Multi-Tom Fills On A Five-Piece Set: Part 1



You are sitting behind your five-piece drumset pretending to be Neil Peart. You've just invented a beat that comes close to something Neil might play in a Rush song, and that makes you feel good; after all, you haven't been playing drums that long. Your confidence increases as the beat becomes more natural and less forced, so you figure, "Why not? Go for it!" and you try an around-the-toms Neil Peart-style fill.

Suddenly, everything comes to a screeching halt and silence fills the room, because even though the fill you wanted to play was within your capabilities, it seems you ran out of tom-toms about an hour before the fill was supposed to end. Now you are upset because you only have three lousy toms and Neil Peart has—how many toms does Neil Peart have, anyway? You throw your sticks down disgustedly and leave the room. Deciding to make more valuable use of your time, you turn on the TV.

Hey! Turn off the TV and get back to your drums! Even though you *only* have three toms, life is still worth living. In fact, if you had the chance to talk to ten of your favorite drummers, you would probably find out that nine of them spent their early years learning on a drumset pretty much like the one you're playing now. And of those ten drummers, the ones with the biggest drumsets might let you in on a secret: They added the extra drums and cymbals to their sets because huge drumsets look good on big stages, and if they weren't in bands that played big stages they'd probably still be playing their smaller sets.

Let's have some fun and adapt some multi-tom fills found in familiar songs so you can play them just as effectively on your five-piece set. We'll start with a standard fill used by many drummers in all sorts of musical contexts. Frankie Banali of Quiet Riot plays this fill in the song "Main Attraction:"



Now, here's an adaptation of that same fill that you can play on your set:



That's too easy, you say? So was the first fill, but you couldn't play that one on your five-piece set, could you? You can play the modified version with no problem, though.

Here is another adaptation of that same fill, but this version's a little more sophisticated:



Why was that adaptation more sophisticated? If you played it correctly (if you didn't play the accent, you played it wrong), the accent on the third count created an "aural" illusion—the sonic equivalent of an optical illusion. Even though you stayed on the same tom during the third count, the accented note gave a feeling of forward motion through the fill, as if you actually had changed toms on the third count. When used wisely, accents can make a normal set sound twice as big.

Frankie Banali also plays this fill in "Main Attraction," but although this fill is similar in appearance to the first one, this fill

takes on an entirely different *melodic shape*:



Here again, the melody of the original fill is salvaged for a five-piece set via a single accent, which makes it sound as if you're moving to another tom:



The drum part to Phil Collins' "In The Air Tonight" begins with this drum explosion:



This is a monster of a fill, not necessarily because of its difficulty, but rather due to its placement in the song. The fill is also very melodic, and to adapt it successfully the melodic shape of the fill must be retained, such as in this adaptation:



These next two modifications of the Phil Collins fill also keep the original melody intact:



As you've seen so far, the snare can be treated as a high-pitched tom to adapt all sorts of fills. Don't be reluctant to use it when you modify fills on your own and are stuck for that high-pitched tom you don't have.

Metallica's Lars Ulrich plays this fill in the song "Master Of Puppets":



In this adaptation, the snare drum is again substituted for a high-pitched tom, and the high-to-low melodic shape of the fill is kept intact as well:



Next month, we'll take a look at a few more ways to adapt multi-tom fills to a five-piece set.



DONY WYNN and LUDWIG

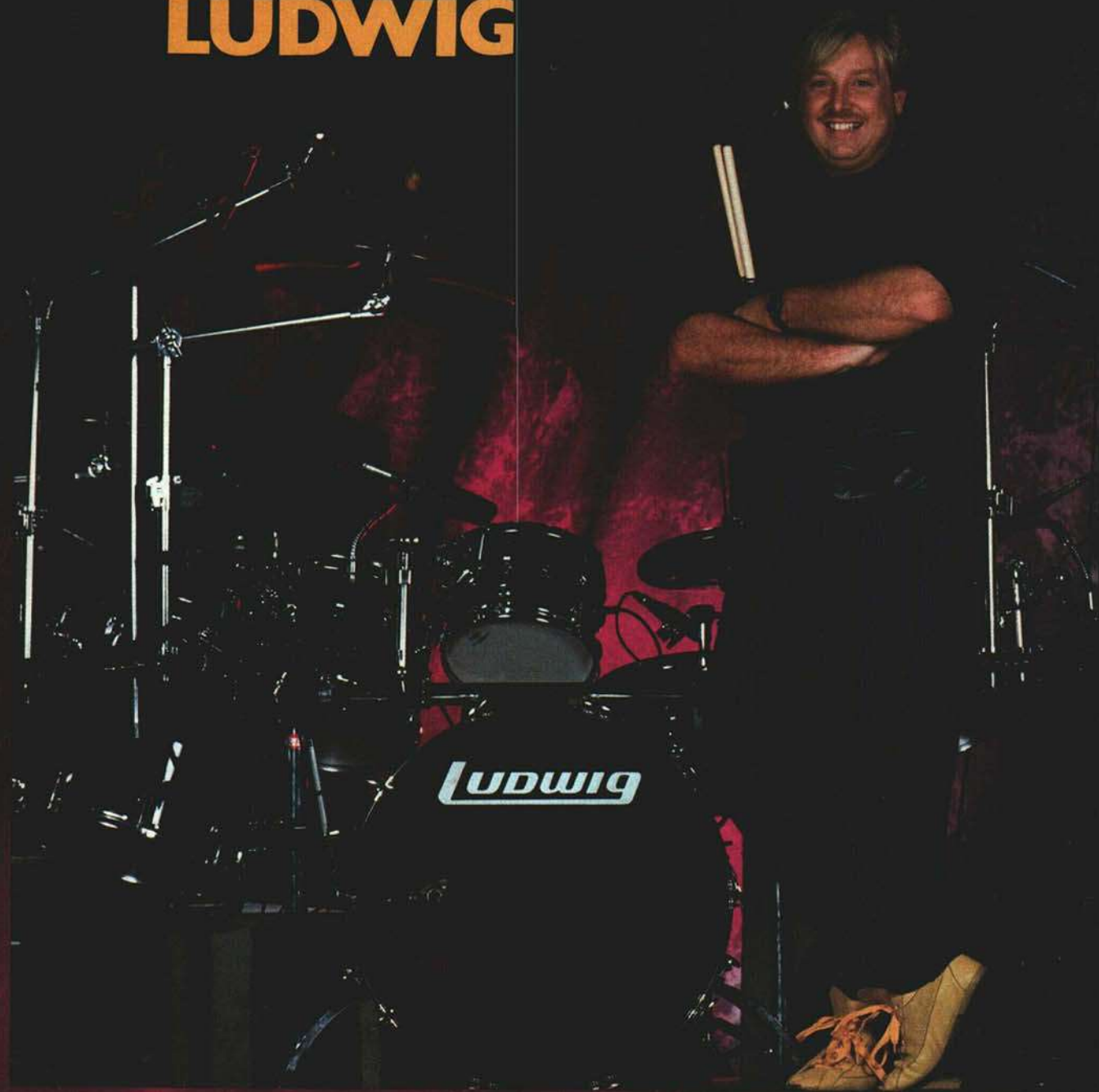

A SIMPLY IRRESISTIBLE COMBINATION

Hear Dony and his Ludwig Super Classics on Robert Palmer's latest, "Heavy Nova." For a full color poster-size reproduction of this ad, send \$2 to: Dony Wynn, P.O. Box 310, Elkhart, IN 46515.

LUDWIG

A SELMER COMPANY



Photo by Lissa Waters

Midway through Robert Plant's tour, Chris Blackwell broke his wrist. Pat Torpey took over the drumset duties, while Chris continued to handle the electronic triggering as well as extra percussion.

"When bands use tapes and sequencers on stage, it isn't a performance anymore."

SG: What was Robert Plant's own philosophy about using all this electronic gadgetry? Was he encouraged in this direction by having younger musicians with him, or did he ask you to use it first?

CB: It worked both ways. There's the obvious play on words in the album title *Now And Zen*. The way he saw it was that a lot of bands, like The Beastie Boys, were sampling Zeppelin riffs, looping them and so on, so why shouldn't he do it? If anybody's got a right to do it it's him, or anyone who was involved with Zeppelin. That's where "Tall Cool One" came from: There are all the Zeppelin samples at the end, and the references. He approached the album wanting to use some of the new technology, but he wasn't quite sure what. So we introduced some ideas to him, and he pointed us in the direction he wanted them to be used. It was a collaboration.

SG: Have you found it at all daunting, playing in a new band with a rock 'n' roll legend?

CB: When he first phoned me, there was a message on my answering machine: "This is Robert Plant. Give me a call." I thought, "Robert Plant—sure"; I thought it was one of my friends messing about. So I called the number he left and I said, "Who is this?" and he said, "Robert Plant." I said, "No, come on. Seriously, who is it?" But it was him, and the first album I ever bought was *Led Zeppelin IV!* My musical influences during my childhood were Zeppelin and bands like that; John Bonham was my hero. And now, here was Robert Plant phoning me up. But I turned up at the first rehearsal and found him to be a really nice guy. It's hard to think of someone as a *legend* when you know him personally as a nice guy. He's just like one of us. Although, when we did Hammersmith Odeon and Jimmy Page played with us, it made me think, "This is serious, Jimmy Page and Robert Plant!" Robert's a very funny guy. There's no sense of pressure working with him.

SG: I wasn't thinking so much of the personal aspect, but rather the idea of playing with an established figure of the rock world. The musical approach must be slightly different than if you were in a band with people of your own age and you'd all come up together.

CB: When he first suggested doing Led Zeppelin numbers, I was rather

worried.

To a lot of people they are sacred, especially in the States. For that

reason there are certain numbers we can't touch, like "Stairway To Heaven" and "Black Dog." But when we started trying a few Zeppelin songs, none of us had to listen to the originals, because we all knew them. They were part of the musical tradition we had grown up with. Having Robert singing the numbers with us made them sound so good that it gave us confidence. There's no real substitute for that voice, and as long as the band is pulling its weight, the song will sound good.

SG: To what extent do you try to recreate Bonham drum parts?

CB: It would be wrong for me to copy exactly what he played, because that was him. The part has got to be right for the song, and I can't improve on what he did. Nevertheless, I try to keep the *spirit* of his part while doing something of my own there as well. As a band we didn't listen to the records and then try to recreate the parts note for note. It's our interpretation of the songs, which is a better way to do it. We're not trying to be Led Zeppelin.

SG: When Robert called you to join his band, how had he latched onto you?

CB: I'd been doing a lot of sessions with Phil Johnstone, who at the time was writing songs for Virgin and plugging away trying to get his material accepted. Phil sent a tape to Robert. Robert liked the songs and he also liked the drummer—which was me. He asked Phil who it was, and then phoned me up completely out of the blue. I was doing Bucks Fizz before I joined Robert, and I came off the road from a Bucks Fizz tour about ten days before starting work with him.

SG: Bucks Fizz is very much a *pop* act, whereas Robert Plant is about as *rock* as you can get. It must have been quite a drastic change.

CB: There was a slight culture shock, yes. But I've got nothing against Bucks Fizz; that was a good, fun gig as well. From a drumming point of view it was a good gig

to do, especially tracks like "New Beginning." There's a lot of stuff going on there, but you don't realize it until you start doing it. Like with the Zeppelin numbers we do with Robert, I found that I knew every song we did with Fizz. I didn't realize that they have had so many hit songs, which just go into your brain and stay there. Although the music is pop and it's manufactured, it has got to be played well. As with Robert's band, there's a serious intent. You've got to approach them both in the same way and give it everything you've got. I never want to give less than that to anything I do.

SG: How did you become a professional musician in the first place?

CB: Between the ages of 19 and 22 I was working for Lewisham Borough Council. It was all quite cushy. They were going to send me on a day-release course so that I could qualify as a surveyor, I'd bought a car, my girlfriend at the time wanted to get married...it all seemed to be planned out. Then one day I just stopped and said to myself, "I can't do *this* for the rest of my life, when I've never even tried to do *that*." So I left my job and became a "professional" musician. All I had was the car, I had no capital, and my girlfriend left me after six months. I did all sorts of things just to live: I sold ice cream from a van, I was a carpet porter, I played in a pub band just to keep playing, and I did free sessions.

Over the years I managed to build things up to the point where I was doing a lot of sessions; but there was nothing spectacular, it was all pretty anonymous. I was doing a lot of work for EMI. If they signed a song-writing act who didn't have a band, I'd be called in with a bunch of other guys to do the demos. There was a group of about nine of us who would always be working together in various combinations. Phil Johnstone became one of these people towards the end of a three-year period, but Doug Boyle was involved all along, as was Phil Scragg, who played bass on the *Now And Zen* album. I've also had a parallel thing going: I write jingles for TV ads and so forth. I've had music in a couple of films, and I write Library Music. I was doing that as well as playing sessions as a drummer.

SG: How did you break into that side of the business?

CB: Quite by accident. One of the people I was doing sessions with got a *JX3P* keyboard when they first came out, and I was so impressed with it that I bought one to fiddle around on, because I'd always fiddled around on keyboards and guitars, ever since I was about 14. A friend of mine had landed a job as Retail Marketing Manager with Virgin, and they were putting together a TV ad for The Virgin Mega-Store in London. They had all sorts of people submitting music to be used for this ad, and my friend said, "Why don't you have a go?" So I thought, "I've never done anything like this before, but I'll have a go, sure," and I got the job. The ad was 60 seconds of cartoons—caricatures of various pop stars. It was the first ad I'd ever done, and it won an award!

IF YOU'RE REALLY SERIOUS ABOUT DRUMMING...

Here's The Smartest Investment You Could Make This Year!



Save money with a subscription to MD—

savings as high as 43% off the newsstand price! Plus, you'll never have to worry about missing an important issue. And your subscription comes with our money-back guarantee. Should MD ever fail to live up to your expectations, we'll refund your money—no questions asked.

- Exciting feature interviews with the world's greatest players—everything you need to know about your favorite drummers.
- Revealing product reviews on the latest acoustic and electronic gear—written to help you make the right decisions.
- Behind the scenes of equipment manufacturers. See how it's made, and visit the people behind the products.
- Your questions answered by the pros.
- The *MD Equipment Annual*—the most complete percussion product listing in print—sent FREE to every subscriber.
- Columns written by the most respected drummers in the world to help you become the very best drummer you can be.
- A wide assortment of musical examples, exercises, rock charts, and drum solos that will challenge you each month.
- Enlightening book, record, and video reviews—your guide to the best materials available for drummers.
- Recorded Sound Supplements let you hear what your favorite drummers are doing—and how they're doing it.
- Chances to win thousands of dollars worth of drum equipment through MD's Trivia Contest.
- Whatever your specialty, *Modern Drummer* covers it all. From rock, jazz, and studio playing to club work, Latin styles, and the latest developments in electronic drumming.

MODERN DRUMMER

The World's First International Magazine For Drummers

...for the serious-minded players of the world

YES, I'd like to get serious with a subscription to Modern Drummer—and save money as well!

BMKT-13

- 1-Year Subscription**
(12 issues plus FREE Annual) for \$25.95.
(Save \$15.40 off the newsstand price)
- 2-Year Subscription**
(24 issues plus 2 FREE Annuals) for \$46.95.
(Save \$35.75 off the newsstand price)

Do not send cash. U.S. funds only. Your subscription will start with the next available issue. Please allow 6 to 8 weeks for delivery.

Payment Enclosed Bill Me Charge MC Visa

Card Number _____

Ex. Date _____

Signature _____

Name _____

Address _____

City, State, Zip _____

Make check payable and mail to:
Modern Drummer Publications, Inc., P.O. Box 480, Mt. Morris IL 61054

From then on, people started to phone me up. But it was completely accidental; I never set out to do it.

One of the calls I got was from someone at DeWolfe. They operate this thing I mentioned before called "Library Music," which involves hiring specially recorded pieces of music to advertising agencies and other similar organizations worldwide. The first album I did for them I had to copy various artists who were in the charts. This didn't

mean ripping them off, but it had to be obvious when you heard that piece of music who it was supposed to be. So I had to reproduce the sound and the chord changes—really the whole vibe of what that artist was about. For instance, one of the tracks I had to do was a Madonna copy, so I copied that—no vocal, just the backing track. The way it works is that the client will receive the album, listen to it, and decide that the Madonna-ish track sounds very hip and

modern and today; which is just what he needs for a presentation launch for a new car. So he'll rent the track from DeWolfe. There's different rates depending on what it's used for, and you can find your music turning up in all sorts of places.

SG: Why can't they use the original?

CB: Well, they can, but the royalty payments are high. But the tracks you write as a library writer are not liable to that, because you are not doing a direct copy of the original; it's more like mimicking it.

The first album I did was like that, but the second was all original pieces of music. One has been used on a TV wildlife program, one's on a soup advertisement. They turn up all over the place. We went to see the James Bond film *The Living Daylights*, and right in the middle there was a piece of my music. I wasn't expecting it, because I didn't know it was there!

SG: You said that you started by doing free sessions. Would you advise people to do that in order to break in?

CB: Well, I did it just to get myself known. Then I started doing sessions for 25 or 30 pounds. They'd very often go on all day and into the night. You'd be working all that time for 30 pounds, and by the time you'd paid your petrol and had a hamburger, it didn't leave you with much. But you have to go through this. It's all to do with getting your foot in the door. You can send tapes of yourself playing to local studios. You can offer to work for nothing if they'd be prepared to try you instead of their drum machine. You can phone up and ask if they'd like to try sampling your drums. If they say yes, you take your drums in, you hit each one once, and they sample it. But at least you're there, you're in the studio, you've met the engineer and the studio manager; and the following week you can call them and ask if they've got any sessions you can do. They might say, "No thanks, 'cause we've got all your sounds sampled already," but they might

Our sticks come in three different



All of them. All have the same, consistent quality and precision craftsmanship. All are shaped from the finest 100% American hickory, and guaranteed 100% straight.

Moreover, all Zildjian drumsticks are meticulously matched for color, weight, heft, and balance. So whenever Rikki Rockett needs a new 2B, it will feel exactly like his old 2B.

2B

SELECT
HICKORY
USA

Zildjian

2B

SELECT
HICKORY
USA

Zildjian

2B

SELECT
HICKORY
USA

Zildjian

just have something for you. You'll never know unless you try.

If you make enough of a pest of yourself, without coming across as an idiot—make it plain that you know what you're doing; you know that you can play well, even if they don't—then you're likely to get a chance. But when you get that chance, don't suddenly become an octopus hitting everything in sight. Just play as simply and basically as you can. Remember that they were probably using a drum machine yesterday. That's what their brains are tuned in to, and you should be able to be similarly reliable.

Another thing you should try if you want to get into sessions is buy a drum machine and learn how to program it. Also sit with your headphones on, with a simple pattern playing on the machine; play along with it until you reach the point where you can't hear it anymore, where every beat you play is so spot on with the machine. You can find this happening in the studio with a click track. You're playing along with the click, and it disappears, so you stop. But the click is still there; you've just been playing so tightly with it that you no longer notice it. If you can play with that amount of accuracy, you can do sessions. Another piece of advice that I'd give is, if you're in a band, don't give up!

SG: This is an interesting point. In the '60s, when Robert Plant first became successful, the way to do it was as a member of a band. These days many so-called "bands" are manufactured by producers, or they are groups of session players backing up established artists.

CB: I've never really been *in* a band before. I've had bands with friends who were doing the same sort of session work as I was. We used to play in pubs, and we'd end up paying to play; it actually cost us to do the gigs. We didn't compromise at all; we were playing what we wanted to play and having a good time. But maybe we forgot that the audience ought to be having a good time,

too. There are bands who stick to their guns and do it that way. It's still possible. But you're right; nowadays it isn't done that way so often. I'm not sure about how it is in the States, but in England bands tend to be put together, so they don't go through that period of struggling and being broke and suffering for your art and all that.

I think it creates a false sense of security, because they've got nothing to fall back on, they've got no track record. It's like getting qualifications: If you go to a university and get qualifications and get a job, but lose that job, you can get another one because you've got the qualifications. If you're in a band that suddenly appears from nowhere and gets into the charts and then disappears, you're only going to be known for being in that band; you haven't done anything else. But the way I came up was slow; it took a lot of work and I did struggle; although I did it as an individual rather than as a member of a band. In many ways I think that struggling as an individual is worse, because if you are in a band at least there are other people you can discuss things with and make plans with.

I think that the mistake a lot of people make is not looking beyond the rotten gigs and the sessions that they do for very little money while they are struggling. You've always got to look ahead and think, "Now I'm doing this, but soon I'll be doing that." If you just accept the situation you're in as being static, and then become dissatisfied with it, *that's* when you get disillusioned and give up. You've got to have ambition to keep you motivated—that combined with determination and optimism. Take the band that has been struggling for a couple of years: Nobody seems to be interested, nobody comes to the gigs, so they split up. But maybe if they just stayed together for another week, that might be the week when the chap from the record company comes along and gives them the deal. There were a lot of my friends who were doing the

same thing that I was when I was about 22, but they did it for a couple of years and then gave up. *Now*, I think, they are a little bit envious. But there's nothing to be envious of; they could have been doing it, too. As long as you've got the initial ability, anyone can do it; it's just a matter of telling yourself you're going to.

SC: A problem is being objective about your own ability and potential, especially if you're trying to create something original.



Chris Blackwell
Robert Plant

Get the gig!

A New Generation™ of Drumsticks
for a New Generation of Drummers.

pro·mark®

Send \$2 for new color catalog.
10707 Craighead Drive, Houston,
Texas 77025 • 713/666-2525

Colors. And they're all the same.

The finish is uniquely and evenly applied—to give you the feel of the wood, not the varnish. It penetrates deeply to keep the sticks stronger, longer.

Pick up any other drumsticks, then pick up a couple of ours. You'll notice something right away:

What makes Zildjian sticks so much the same is the very thing that makes them different.

Zildjian

We take sticks as seriously as we take cymbals.



Berklee



Music Study Publications
from one of the world's
leading colleges of
contemporary music.

**Manual for the Modern
Drummer/Dawson, DeMichael**
50449560 \$10.95

**Four-Way Fusion for the
Modern Drummer/Norine**
50449540 \$10.95

**Rhythm Section Studies
for Drums/Sterling**
50449610 \$ 8.95

**Multi-Pitch Rhythm Studies
for Drums/Delp**
50449550 \$ 8.95

**Virtuoso Studies for
the Drum Set/Norine**
50449600 \$10.95

Now available from your local music
dealer; or, enclose payment
with order plus \$2.00 handling
charge and write:

**HAL LEONARD
PUBLISHING
CORPORATION**

P.O. Box 13819, Dept. MOD 11
Milwaukee, WI 53213

CB: Yes, but that's when you find out who your friends are. If you have a friend who is able to listen to one of your songs and say, "That's terrible, that's rubbish," that's when you know you've got a good friend. If somebody pacifies you and says it's great when he knows it isn't, because he knows that you've spent a lot of time on it, *that's* the sort of friend you can do without. That's the value of having a good producer in the studio; he will be able to come up with an objective view and maybe a fresh slant that the band wouldn't have thought of.

SG: Can we come around to your singing? Do you have any problems doing this as well as playing drums and triggering things?

CB: When you're doing three things at once, you've got to concentrate a bit more on what you're doing; but after a while you get so that you can do it without thinking about it. It's like riding a bike and talking at the same time: It's not really difficult, but it takes a bit of working out at first. In the next part of the tour I'm going to be using an AKG radio headset so that I won't need to switch mic's when I go out front to play the pads. I might even be playing some guitar or mandolin as well; so it'll be very handy to be able to come out from behind the kit and keep the same mic'.

SG: A problem with singing and drumming at the same time is that your breathing is coordinated with your singing, and not enough oxygen is finding its way into the bloodstream to feed the energy output from the limbs.

CB: Yes, I know what you mean. There are things I can't sing for that reason. On the last tour I was supposed to be singing on "Trampled Underfoot," but it was physically impossible to sing and play drums at the same time. It isn't only the business of breathing, there's the vibrations that go through your body as well. If you're trying to hold a high note, you can't do it while you're hitting and kicking things; your voice wobbles, and there's nothing you can do about it. We had to very carefully work out which parts I *could* do. They are normally the easy parts, which are well within my range. Falsetto parts are out, except on "Big Log" when I'm not playing kit, but playing marimbas on the pads.

SG: Playing something melodic and singing as well can produce other problems.

CB: Well, guitarists and keyboard players do it all the time, although a lot of the time they are strumming and accompanying themselves. But, having said that, I've seen people singing *and* soloing on guitar at the same time. That must be really weird. It's like playing a drum fill while you're singing, trying to hold the note and play the fill. But a lot of drumming is repetitive, and you just do it automatically. Actually, the marimba part that I play on "Big Log" is repetitive like a drum part, so I don't find it difficult to combine the two things.

SG: You play right-handed on a left-handed kit. Why is that?

CB: Because my father is left-handed! Seriously! It goes back to when I was 11 years

old and he bought me my first kit. He didn't know much about drums, but he set it up the way he thought it ought to go—which happened to be left-handed, and I've been playing that way ever since, open-handed.

SG: On stage, do you limit yourself to an acoustic sound miked up, or do you trigger samples to reinforce it?

CB: I only trigger on the kick and snare, and only on certain numbers. There are four numbers in the set where I'm triggering additional sounds from acoustic drums, and even then it's relying more on the acoustic sound than the sampled sound. But Clive Franks, the sound man, is brilliant. He did Peter Gabriel and Elton John before doing us. He's known for his drum sound, and he gets phenomenal results. For instance, I like snare drums to feel really bright and crisp. I tighten up my bird's eye maple snare drum quite high, and get a lot of bounce out of the heads. Even though it's 8" deep with quite a thick shell, it sounds bright and clear; and with Clive at the other end it sounds great.

SG: You spoke earlier about ambition and motivation. Do you still have ambitions you hope to fulfill?

CB: Yes. I'm very happy with the gig I've got as a drummer, but I'd love to write a film score. That's my burning ambition. When I heard that little piece of my music in *The Living Daylights*, I wanted to jump up and down and say, "Hey everybody, that's me!" It's such a thrill, I'd really love to do a whole score. Stewart Copeland has done it with the music for *The Equalizer* series on TV.

SG: If you listen to the music from *The Equalizer*, it's easy to guess that it's written by a drummer.

CB: Yes, I think that's bound to happen. Take Eric Clapton doing the theme music for *The Edge Of Darkness*; you could hear that it was a guitarist who wrote it. That's what I'd like to do: make a name for myself as a drummer and then branch out as a composer.

SG: Do you ever get mistaken for the other Chris Blackwell, who is the boss of Island Records?

CB: Oh yeah! All the time. It's a good name to have actually, because you have no trouble getting hold of people on the phone. If you call someone's office, you get put through straight away. It works really well. On the other hand, it nearly worked against me the other night. We went to see Belinda Carlisle at Hammer-smith, and my name was on the guest list. There was the usual security on the door, and when I gave him my name, he said, "Chris Blackwell—he's the boss of Island Records, isn't he?" He was obviously thinking, "This character isn't the boss of Island Records," and I was saying, "Yes, *he* is, but...." It was a bit tricky; they nearly didn't let me in. The people at the bank thought that I was the chap from Island Records for a while, but then they looked at my bank balance and realized that I wasn't.



Vic Firth strikes again!

New Products



Peter Erskine Signature

A hickory stick designed with Peter's style and artistic ability in mind. It's light, fast, and has excellent cymbal response. 16" long, 1/2" thick, with a round tip.

Rock Rake

Stiffer, thicker bristles produce brilliant sounds for rock and heavy metal; also retractable.



Alex Acuna "Conquistador"

A turned hickory timbale stick designed by Alex, to accommodate his dynamic and explosive style. The stick is flaming red, and it really burns! Rolled for straightness, and pitch-paired. 16" long, 7/16" thick.

Jazz Rake

A retractable brush featuring thin, flexible bristles for fusion and jazz.

Distinguished artists and their signature sticks - classics that never go out of style.



Steve Gadd



Harvey Mason

Vic Firth, Inc.
323 Whiting Ave., Unit B
Dedham, MA 02026
(617) 326-3455 • 326-3512
FAX 326-1273

**VIC
FIRTH®**

Learning Polyrhythms:

MUSIC KEY



The word "consonant" is taken from melodic harmony. It's defined as two notes, or the notes in a musical chord, that sound together in a way that is logical to our ears. Rhythms, and especially polyrhythms, can work the same way. The following ratios and sound patterns are what I consider to be the basic (consonant) polyrhythms. First, learn the sound pattern, and then try to hear and count the polyrhythm ratio against the basic pulse (in this case 4/4).

6 over 4

Sound Pattern:



Count:

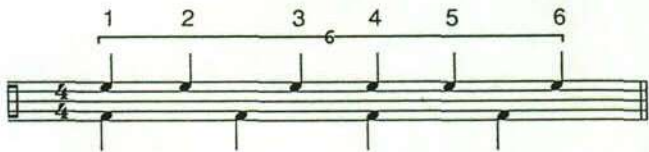

3 over 4

Sound Pattern:



Count:

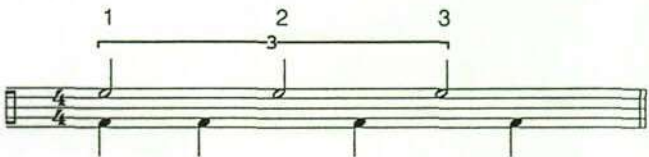

5 over 4

Sound Pattern:



Count:

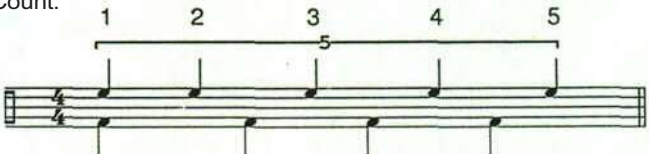

7 over 4

Sound Pattern:



Count:

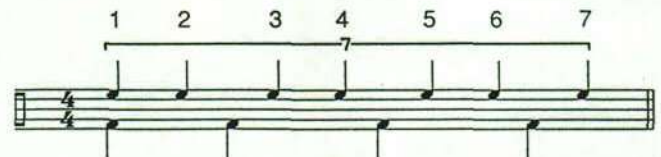

Subdividing Polyrhythmic Ratios

Now that you have learned how to hear and play the basic polyrhythmic ratios, it is time to subdivide (break up) the top rhythm into its component parts (i.e., 8ths, triplets, and 16ths). The first polyrhythm I will use is 6 over 4. I've chosen to start with 6 over 4 because of its comfortable relationship to the 4/4 time signature. You should be able to grasp the concepts more easily in 6 over 4 and apply them to the other consonant polyrhythms.

First, we will subdivide the six quarter notes into twelve 8th notes. Start by playing the quarter-note pulse on the bass drum:



Next, add the six quarter-note polyrhythm on the snare drum:



Now, divide the six quarters into 8th notes:



When playing these types of exercises, it is helpful to play along with a metronome or a drum machine.

The next rhythmic subdivision we will look at is the six quarters divided into triplets. Here we find the first rhythm that is not found in 4/4 notation. It is exclusively a polyrhythmic product.

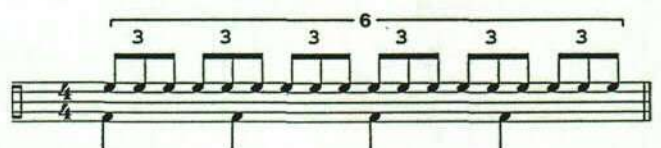

by Peter Magadini

Part 3

To make it easier to play this example, play the following three-bar exercise so you can hear where the subdivided triplets should be played; play an 8th-note triplet for each of the six quarter-note triplets.

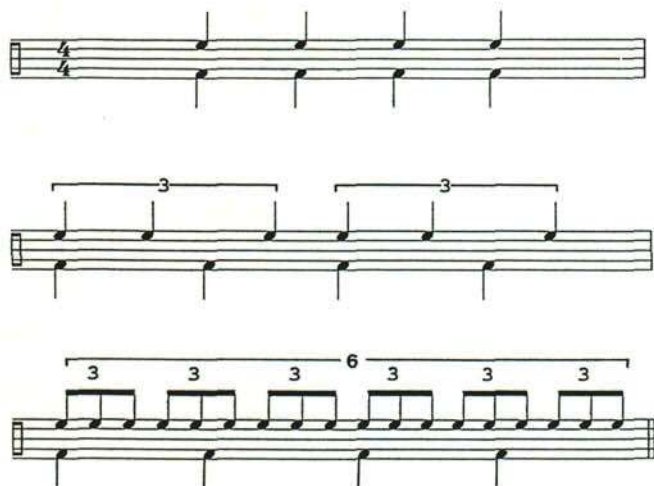

The last logical subdivision of 6 over 4 is the subdivision of the six quarter notes into 16th notes.

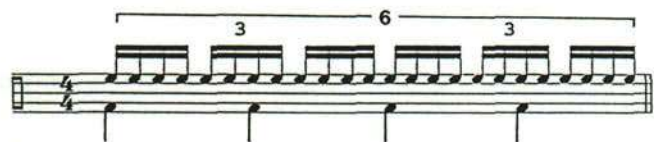

As with the 8th-note triplet subdivision, play the following example so you can hear exactly where the 16th notes should be played—four 16th notes for each quarter-note triplet.

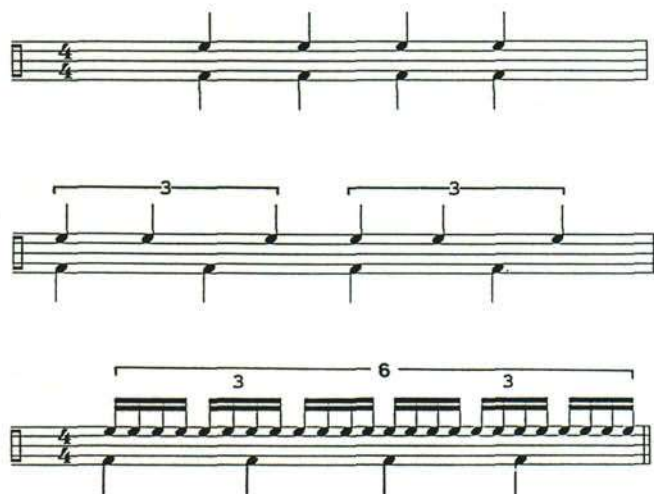

The next step for you is to learn the polyrhythmic subdivisions for the remaining consonant polyrhythms I mentioned in the beginning of this article. Subdivide 8th notes, triplets, and 16th notes in 3 over 4, 5 over 4, and 7 over 4 polyrhythms. Follow the same steps you have just used to learn the subdivision of 6 over 4. Use the exact same procedure.



Solid snares.

Noble & Cooley solid maple Classic snare drums. Solid quality. Solid craftsmanship. Most likely the best snare drums you'll ever play.

Solid maple.

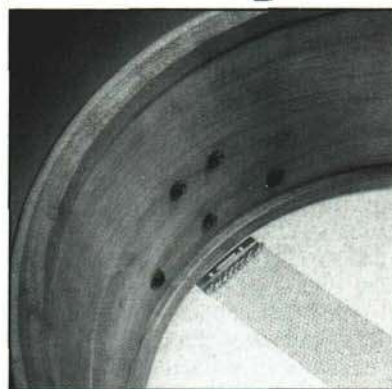

NOBLE & COOLEY CO.

Water St., Granville, MA 01034
413-562-9694

HOT ROD

Multi-Rods

The sizzling, new multi-purpose sound used and endorsed by multi-talents Billy Cobham, Bill Bruford and Carl Palmer.

When sticks are too loud and brushes too soft, Multi-Rods are just right. This fresh, hot new sound is a Pro-Mark exclusive. Each Multi-Rod is made of 19 select Minnesota birch dowels 1/8" x 16" long, banded together. . . With a natural rebound that sizzles.

pro-mark
The World's Class Drumsticks

See your local dealer or send \$14 a pair to Pro-Mark, 10707 Craighead Dr., Houston, TX 77025. Send \$2 for new color catalog.

by Rod Morgenstein

I'll Never Forget The Time...



Photo by Rick Melkin

I'll never forget the time...the Dregs were on a West Coast tour promoting one of our albums. I was in the dressing room of the Roxy Theatre in L.A., when I heard an unfamiliar voice calling my name. As I turned, I noticed this guy peering in the window. "Hey Rod, remember me? I met you four years ago in the bathroom of such and such club in South Carolina." Now, this was hardly unusual, except for the fact that this was a second-floor dressing room and the guy was hanging from the window ledge desperately trying to hoist himself up. Additionally, he apparently had climbed into a trash-filled dumpster directly below to get within striking distance of the window ledge. The memory of this experience will be with me forever, as will countless others, all resulting from playing and touring in a band. For some reason, however, many of the most memorable moments usually involve someone being put in an embarrassing position, a close call, or even a degree of tragedy.

Like the time...the band jumped in the air for the concert's grand finale and Owski (our keyboard player at the time) crashed right through the stage floor and ended up wedged in with just his head and torso visible to the crowd! Of course, this was not planned as part of the show. But hey, this is show biz, and poorly constructed stages are one of the many occupational hazards that go along with the turf. Certainly, we always hope for the gig to go smoothly, without a hitch. But somehow, as embarrassing or tragic as some of these mishaps might be at the moment they occur, they have a way of becoming extremely fun conversation pieces as time marches on.

Like the time when...the Dixie Dregs (a.k.a. the Dregs) were playing a college

gymnasium several years back. We were jamming on the song "Cruise Control," when at this certain frenzied moment we would routinely detonate a home-made concussion mortar bomb. The explosion, which made quite an impact, always worked (safely, we thought) and made the crowd go crazy. Well, little bekownst to us, a hairline fracture had developed in the bomb housing unit over a period of months and turned our routine effect into something along the lines of a hand grenade. Needless to say, I was very impressed as I watched Allen, our violinist, flying through the air backwards approximately ten feet. What a showman, I thought! Of course, it wasn't until we finished the song that we realized what had happened. Our toy bomb had blown a huge hole in the stage, sending shrapnel flying in all directions, breaking Allen's leg and shattering a policeman's walkie-talkie. Lucky for us, that was the full extent of the damage. And, oh yes, there was no encore that evening.

Now, as they say in the business, the show must go on. Allen played the next few months in a full leg cast, sitting down, of course, and he was a real trooper. To add some humor to our concerts, he would remain on stage in his chair with a blanket covering his head and body, the stage dark with the exception of one spotlight centered on this ghostly figure, while the rest of us would wait off stage for the encore. Yes, somehow there's a comedy in almost anything.

While on the subject of the stage effects, on occasion we also used flash pots. At one such concert the flash pot set fire to (you guessed it) Allen's hair, only he didn't know it because it got him from behind. As the music continued we all tried to signal him that his head was smoking. But he took our distorted facial and body gestures to be that non-verbal musician's communication and shared intensity in the music. Fortunately, the song ended soon enough and the situation was remedied. When serious tragedy is avoided, these things have a way of becoming very funny.

Another "bomb" story that comes to mind is the time in Atlanta at the New Great Southeast Music Hall when several fans somehow had placed themselves within inches of the homemade explosion. As the moment of detonation drew closer and closer, our stage manager, Skoots, gestured frantically for them to move away. But of

course, they had no idea what he was trying to convey. Well, just like it happens in the movies, Skoots dashed across the stage and dived into the fans, knocking them out of the way the very moment the bomb exploded. What an act of heroism. No casualties to report.

In this final story, I'm reminded of the time we were on tour in Florida and received an urgent message to call home. Home, at the time, was Atlanta, Georgia. When our road manager, Jeff, phoned his girlfriend, she informed him not to worry, but the Dregs band house had blown up. Blown up?! This was the house where we rehearsed and stored all of our extra gear. I had over 30 drums in there, not to mention umpteen cymbals, cases, hardware, heads, and other prized percussion treasures. The other guys had guitars, basses, keyboards, and amps stored there, as well as stacks of assorted Dregs tee shirts. Fortunately, we were able to come home the next day, but what we found was a burned-out shell of a house. Apparently, the heating unit had exploded, causing a severe fire, which nearly destroyed everything inside. Of course, none of us had musician-equipment insurance, because one never thinks it's going to happen to one, does one? I clearly remember spotting what appeared to be one of my all-time favorite cymbals in the rubble, but when I picked it up, it dissolved into pure dust. Although it was so depressing, we managed to make the best of this tragic situation. We called our next album *Unsung Hems*. And looking for a wartime battlefield setting, we used our besieged home as the backdrop for our promotional photos—which, by the way, came out looking very authentic!

The only items that made it through the fire were the tee shirts, due to their location in the house. This was evident by the fact that, by the time we got to the scene of the blast, every kid (and I mean every kid) in the neighborhood was wearing a Dregs tee shirt! I can still remember all those faces checking us out so cautiously, keeping a safe distance, not even aware that the "stolen merchandise" they were wearing bore our names and likenesses!

The memory of this story and all the others, even with their varying degrees of conflict and tragedy, always brings a smile to my face and reassures me that I made a great choice in choosing music as a career.

"DRUM SHOP OF KANSAS CITY"
Professional Products and Service
Great Inventory and Prices

(816) 361-1195

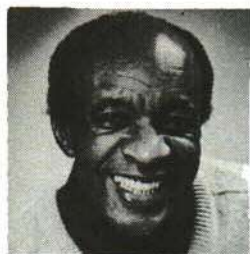

ACTION REACTION U.S.A., Inc.

Ed Thigpen uses these for Study & Instructing
Books & Videos
 by Performing Artist/Educator Personalities



- The Sound of Brushes** + 90-min. cassette – Ed Thigpen. “The # 1 book on brush technique” \$ 15.00
- Rhythm Brought to Life** + **Rhythm Analysis/Coordination** (2 bk. set) E. Thigpen
 A thorough basic study for this neglected area \$ 8.00
- Latin American Percussion rhythms and rhythm instruments from Cuba and Brazil**
 (183 bk. + 3 cassettes) “A must for every percussionist library” \$ 39.95
- Studio & Big Band Drumming** + cassette – Steve Houghton \$ 15.95
- Even in The Odds** – Ralph Humphrey – “Fantastic for grooves in odd meters.” \$ 12.50
- Essential Techniques for Drum Set** – Ed Soph
 “Creative exercises totally based upon the Jazz Triplet feel.” \$ 8.00
- Joe Pocaros’ Drum Set Method** – “Excellent study for applying rudiments to the drum set.” \$ 25.00
- The Art of Modern Jazz Drumming** – Jack De Johnette & Charlie Perry –
 “An informative, applicable approach to modern drumming.” \$ 15.00
- 4 Way Coordination** – Marv Dahlgen & Elliot Fine –
 “Great exercises for gaining total independent co-ordination.” \$ 8.50
- Alfred’s Drum Method Books, # 1 & # 2 book** – Sandy Feldstein & Dave Black – “The ultimate
 approach for instructing beginning & intermediate concert band and orchestral percussion.” each \$ 7.95
- Drummers: Masters of Time** – Steve Davis – A “see and hear” analogy of Jazz Masters “Time” \$ 8.95
- Drum Control with Triplets** – Dennis Venuti \$ 5.85
- Drum Control with Sixteenth Notes** – Dennis Venuti \$ 4.95
- Dave Weckl – Contemporary Drummer** + 78-minute cassette, 9 studio charts, and book \$ 32.00

Note: Please add \$3.00 for postage and handling of each book priced at \$25.00 or more. Add \$2.00 for postage/handling of each book priced below \$25.00.

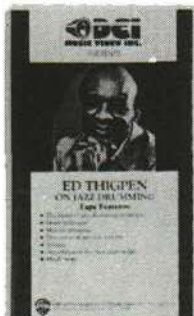

- Videos:** check – ___ VHS ___ Beta
- Ed Thigpen on Jazz Drumming** \$ 39.95
- Latin American Percussion from Cuba & Brazil** \$ 39.95
- Also available:
- Steve Smith, Part One – Part Two** each \$ 39.95
- Steve Gadd, Up Close** \$ 49.95
- Steve Gadd – In Session** \$ 59.95
- Dave Weckl – Back to Basics** \$ 39.95
- Snare Drum Rudiments** – Pat Petrillo (30 min.) \$ 29.95
- Louie Bellson – The Musical Drummer** (60 min.) \$ 49.95



Mail check or money order in U.S. funds only to Action Reaction U.S.A., Inc. c/o Donald Meade, 617 East 83rd Street Dept. MD., Chicago, IL. 60619. Note: Because of weight of videos please add \$4.00 shipping – \$7.00 outside U.S. – PAL available – add \$6.00/tape. – In Canada: add \$10.00 Canadian to U.S. price (+ \$7.00 postage).

can edit those if we choose to, but I still like the attitude of, "We're all playing right now, doing this together." Anything wonderful can happen, though it can be quite the opposite, too. It can be a completely lackluster take, and then you just do another one. Another challenge is to make as much of the album as you can dynamic—even within the same tune—with soft passages and smoking things. The CD medium can handle that; you can fill it up with all kinds of busyness, and then be ultra-simple, too.

SS: That seems to be a trademark of the BB's' music.

BB: I think so, and we try to do that. Often times we comment on how, when we hear

our music played on FM stations around the country, it doesn't sound as polished as some of the other things or as highly produced as some of the fusion bands. But I like that, because it seems spontaneous. We are concentrating on what things sound like, but not to the degree where it gets so slick it loses excitement and spontaneity.

SS: You can certainly raise the roof when you want to, but you're not afraid to play very simple and subtle parts much of the time on the albums. Do you make a conscious effort to lay back, or does the music just naturally pull what's appropriate from you?

BB: The music does, and also stylistically I've always tried to play simply and then

play complexly; the variation between the two makes some musical interest. I went to art school in California and studied animation, and I had a wonderful design teacher who taught me how to be simple and complex—to start out with a simple idea and then elaborate on it.

SS: What other design elements lend themselves to music for you?

BB: I think another one would be repetition with variation: creating drum parts that may use a certain repeating pattern, but with a little accent once in a while or a turn or twist to it. I guess one of my main gripes with the sequenced drum stuff is that it's so predictable. When you repeat something, but have variables to that pattern where it can turn or twist, you can play a line that sets up kind of a tension so that the listener feels, "Okay, I've heard that, but now I want a little change; I want to be surprised." That surprise element is something that I try to use.

SS: It sounds like music and art are pretty good partners in your career.

BB: They really are. I try to do the same thing within a drawing: I'll have what we call "thick and thin," a drawing that has a heavier line in part of it and then light, delicate areas. I try to combine those to give it some interest, so your eye can travel around the drawing, and it will feel like an interesting trip.

SS: You do a considerable amount of riding on things other than a ride cymbal or a hi-hat. Everything from blocks and bells to Hawaiian bamboo sticks can be heard on the albums. Since nearly everything is recorded live without overdubs, you must have an interesting studio setup.

BB: That's also a challenge, not having the options of doing overdubs. I set stuff around on a folding chair or a stool, or on a tomtom that's not being used. It's fun to have the challenge of setting things up in different ways, trying to get to them, and trying to hit things and make it musical—and use, as you say, things other than a ride cymbal every time there's a solo section for the sax player or a piano section or something like that.

SS: Your live playing is fairly raucous compared to your studio work.

BB: Well, I don't know how to answer that! Tonight especially was a case where we were a little bugged with the sound we were getting through the monitors. Sometimes you just get angry and say, "Well, we're going to blow through that, and we're just going to play. We're going to lock in and do what we do, and if it comes out in the house, great. If it doesn't, we're still going to do what we do." Sometimes we need a kind of intensity to get the music to go out there, and to kind of demand that the people listen to us.

SS: How much does your drum setup change for live shows?

BB: It's pretty much the same. I specify certain drum sizes, and I use P.B. drums from a friend of mine in L.A., Gary Grimm. He and I sat down and designed the set—

NEW FROM HOT LICKS VIDEO!

TICO TORRES OF BON JOVI Drumming Essentials

For beginning through advanced drummers, this video covers more ground than any other. Let Tico, one of the world's top drummers, teach you about preparing the drums for studio work, miking tips, tuning the snare & other drums, latin rhythms, "whale" sounds, cymbal work, dynamics, and even some exercises to help strengthen the lower back. Plus, you'll learn about his drum parts to some of Bon Jovi's biggest hits! Jam-packed! (one hour)



TOMMY ALDRIDGE OF WHITESNAKE Rock Drum Soling & Double-Bass Workout

Renowned for his flamboyant solos and double-bass work, Tommy covers a lot of ground in this hour-long video. You'll learn double-bass balance, 3 and 5 note patterns for the feet, double-bass licks and solos, bass drum substitutions, triplet figures, stick twirls in soloing symbol "chokes", double-bass shuffles and soloing with your hands! An incredible workout for the advanced as well as beginning player! (one hour)

YES! Please send me:

- TICO TORRES OF BON JOVI (\$49.95)
 - TOMMY ALDRIDGE OF WHITESNAKE (\$49.95) (Also Available)
 - THE CARMINE APPICE MASTER CLASS (\$49.95)
 - VHS BETA PAL (VHS ONLY)
- I enclose \$_____ check or money order payable to Hot Licks Productions Inc. (US currency only) NYS residents add local sales tax Postage: \$4 per video in U.S. and Can. \$7 Eur. \$ S. Amer., \$9 Asia & Austr.

CALL THE HOT LICKS HOTLINE MD 5-89 914-763-8013 TO PLACE YOUR COD OR CHARGE ORDER NOW!

Name _____
 Address _____
 City _____ State _____ Zip _____
 Phone _____
 Charge to my VISA MasterCard
 Account # _____ Exp. date _____
 Cardholder's Signature _____

HOT LICKS PRODUCTIONS INC PO BOX 337 POUND RIDGE, NY 10576

sizes, colors, and all that stuff. It's like a part of me, that set; it's an extension of myself as a musician. For years I just had standard-size drums, but I love using these; they're a little smaller and I can get to them quicker. I also use the RIMS mounts from another friend of mine, Gary Gauger in Minneapolis. So between those two things I feel like I have a great live kit, and they work well in the studio, too.

SS: What size drums do you use?

BB: I use 8" and 10" toms mounted on the bass drum. Sometimes I'll pull the 10" off and just use an 8" in more of a traditional jazz sense. On the floor I suspend 12" and 14" toms, and the depths vary. I go with a 20" bass drum pretty much exclusively, because I like the size of it. I've never cared for big sizes; I don't feel they move fast enough for most of the music I play. The snare drum is a 5 1/2" wood-shell, which I've been using exclusively, also put together by Gary Grimm. For years it was strictly all-metal snare drums, but I like the warmth of a wood snare, especially the one I'm using now.

SS: How about your cymbals? You don't seem to use many compared to a lot of players.

BB: Well, I lighten up a little for the road because my back has been a little on the fritz and I just couldn't carry a whole lot. I use a 20" K Zildjian Dark, a Light Ride—I love those cymbals; there's such an airy sound to them—and the new K Custom which is a really nice cymbal with a lot of clarity and not a lot of wash in the background. I like small crash cymbals. I don't have anything bigger than an 18". The biggest one I have here in Chicago is a 17", and I used a 15" Brilliant K Dark crash, which has a nice voice to it. I've been using splash cymbals a bit more, little 8" and 10" ones. As far as hi-hats go, I've been sold on the 13" size and not anything bigger. I like to use a heavier bottom cymbal with a K Brilliant on top.

SS: Your drums sound pretty open and resonant. Do you use tape or any muffling at all on the heads?

BB: Only on the snare drum; I like to cramp that down just a bit, although for some effects sometimes I'll take everything off the snare drum and get more of a ring.

SS: Like a Bill Bruford sound?

BB: I think so. When I first heard *The Yes Album* I was kind of mesmerized by the sound he went for. He was one of the first guys I heard whose sound really surprised me, and I thought it was really clever.

SS: How about muffling on your bass drum?

BB: I use a down pillow inside. When I'm playing live I usually leave both heads on, but sometimes they like the front head off for onstage isolation and so they can get a mic' in there to get a nice solid bass drum sound. In that event I put a weight in there to push the pillow up against the head and keep it tight so I have some tension there.

SS: What are your approaches to tuning, in the studio and live?

BB: Each drum has a resonant pitch where

it feels the best. I like to use two heads on everything. For me, the studio sound and live sound are similar. The drums sound pretty nice just by themselves, so a decent sound man can get that sound. And Tom Jung, who does the DMP projects, is kind of the fifth musician in the band; he knows kind of what we want, and we come up with something that I think sounds pretty fine.

SS: How involved do you generally get in engineering your drum sound?

BB: I leave it pretty much to T.J. in the case of BB's projects. With some engineers I'll ask for certain things. Sometimes engineers make the bass drum too pointed; it sticks out of the track too much. I like to have it

back a little bit and feel it but not hear it too loud.

SS: Do you ever use electronically generated drum sounds?

BB: Very rarely. Our first disc we did in '78 was an analog vinyl record, and we had *Syndrums* at the time. Since then I've used some effects—triggering my acoustic drums once or twice—but I haven't really gotten into the electronic drums. When I find some sounds unique to me I may get some pads and see what I can figure out.

SS: "Sleepwalker" from Neon sounds like it uses a drum machine in the intro.

BB: Jim Johnson cued that, and I just played percussion over it because we didn't overdub. And then he punched it out at the

**ENCORE DRUMS.
QUICK CHANGE
FOR THE BATTER.**

The difference is PowerSnap—Encore's exclusive quick-release lug that lets you change heads in a flash. Snap open to release, snap closed to secure the head—and play. It's that simple. But, of course, PowerSnap convenience is just the beginning. Encore is topline all the way—with a unique center shaft/swivel plate assembly for infinitely-variable tom tom setups. These are drums by drummers, for drummers. The Remo difference.

**REMO
MAKES THE
DIFFERENCE!**

REMO, INC.
12804 Raymer St., No. Hollywood, CA 91605

Attach your present mailing label here, or write in your old address.
Please include customer code number.

MOVING TO A
NEW ADDRESS?

New Address

NAME: _____

ADDRESS: _____

CITY: _____ STATE _____ ZIP _____

WECKL on AUDIO and VIDEO!

Dave has become one of today's most admired and influential drummers. Together with DCI Music Video he has created two state-of-the-art instructional packages.

CONTEMPORARY DRUMMER + ONE presents a unique approach to learning how to read and interpret charts. It consists of an **audio cassette** with nine tunes, (each with and without drums), nine separate **studio charts**, and a **comprehensive book** which explains Dave's approach to each piece.

This package now comes in a plastic storage case which is also available separately.

BACK TO BASICS is a **video-tape** on which Dave outlines his philosophy and technical approach to the drums. He presents invaluable information on **stick control, brushes, foot technique, independence** and more. Plus, he performs with several tracks from **Contemporary Drummer + One** and plays some explosive solos. An encyclopedia of drumming techniques. An amazing video from an amazing drummer.

To order, check with your local music retailer or use the coupon below.

Please send me: **Back To Basics** (video) \$39.95 VHS Beta 5-89
 Contemporary Drummer + One (audio/book/charts) \$32.95
 (in a plastic storage case)
 Plastic Storage Case for Contemporary Drummer + One
 (\$4.00 including shipping)

Please add \$4.00 shipping and handling per order (\$7.00 outside the U.S.) N.Y. State residents add 8 1/4% sales tax PAL available—add \$6.00. (allow 2-3 weeks for delivery)

Make check or money order payable to **DCI Music Video**
541 Ave of Americas, New York, NY 10011



Name _____
 Address _____ Apt. # _____
 City _____ State _____ Zip _____

Visa/MC Accepted (circle one)

Card # _____ Exp. _____ Signature _____

To order by phone (Visa/MC) call: 1-800-342-4500 (N.Y. State (212) 691-1884)

In Canada: Add \$10.00 Canadian (plus \$7.00 shipping) In Europe: Music Mail Ltd., 43 South Molton St., London W1Y 1HB, Tel. 01-857-6309

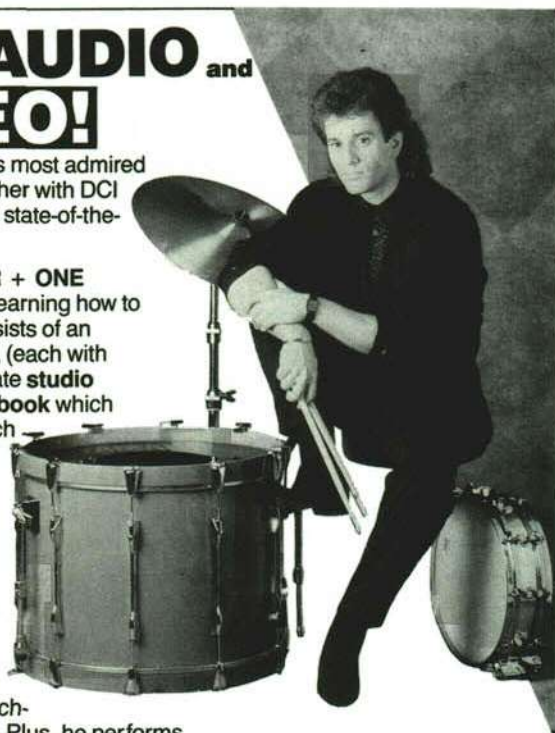

chorus of the tune, and we tried to keep the tempo constant.

SS: Is there any electronic percussion in the new BB's project?

BB: Not really. I still feel real acoustically comfortable. On the tune "Ireland," Tom Jung did a real heavy digital delay on the snare, making it sound like about 50 snare drums. I think you can get some real interesting sounds just with the peripheral gear that is available at a good studio. I'm not putting down the electronic drum scene; I just haven't delved into it enough.

SS: You've all contributed compositions to the BB's albums. Tell me a little about "Bergland" from the *Big Notes* disc.

BB: That was the first tune I ever wrote, and it was really scary to bring it into the rest of the band. But I had some confidence that if I borrowed someone's synth, I could start to hear things and, while really not knowing what I was laying down, record it and bring it to the guys, and they would make something of it. They did, and we had fun.

SS: I noted that one reviewer wrote a comment to the effect that "Bergland" begs to be choreographed.

BB: Gee, maybe that would be a project for animating—doing a video and having some animation—because that's kind of my artistic forte right now. I guess I'm looking for a tune to do. If somebody wanted to choreograph it for dancers—modern dance or whatever—I'd be very flattered.

SS: What's the story behind "Toy Chest," one of your pieces from the *Neon* album?

BB: My father—rest his soul, what a beautiful guy—made toy chests for each of the kids in the family. Each one had a little cushion top that you could sit on. When you raised this top you had all your favorite toys in there, and he had our initials on each one. It was like a world unto its own; open that toy chest and there were your toys. I just thought, "What a thing to write about." When I first started to write it was helpful to take experiences from my past—especially touching ones like that—and try to write as though there was a tune coming out of this lovely experience.

SS: What's the tiny drum you play on part of the tune?

BB: It's one of those LP chrome, little thin-shell things [tamborim]. I used a full-size snare, too.

SS: Each of the BB's albums seems to have a different mood. *Tricycle* was somewhat "aloof," *Tunnel* was "fun," *Big Notes* felt deep and emotional, and *Neon* seemed happy and sure of itself. The tunes I heard from the new album sound a bit closer to what might be called "traditional fusion," a lot more energetic. Is the group moving in that direction?

BB: It's been a while since we did *Neon*. We were recording for the first time in L.A., and we just had a new energy. We used some different combinations; we had some horn players and a percussionist. I would disagree in the sense that *Neon* was, to me, a little more pensive. It was a band going through changes. At that time I threw my

back out and wasn't able to finish the project as scheduled, Billy had just done a solo project and I think he was exhausted at the time, and we were musically maybe a little more "inner." I think after Neon it felt good just to blow it out and have fun with the new project.

SS: You mentioned using a percussionist on the new album.

BB: We felt we wanted to fill a track up with more than I can usually accomplish in a live setting. Flim suggested Luis Conte, who was just marvelous to work with. He brought a lot of sensitivity in, as well as a lot of ability and confidence as a player. We felt the time so well together, and Tom [Jung] even said, "It sounds like you guys have been playing together for about ten years." It just felt real good, and we listened really hard to each other.

I think good players will give space to each other. If a drummer and a percussionist are both in a position where their egos aren't out of balance, they can each let the other one fly and give him the support that he needs. We did two tunes on the new disc, one on which I had a little more of the spotlight and the other on which Luis did more soloing and filling. It was really a nice tradeoff; I could lay back and let him play all of his things, and then when it came to the other tune he could support me. To work with a guy like that was really a treat.

SS: Flim & the BB's is sometimes categorized as a "new age" group. What's your reaction to that?

BB: Ugh. What is "new age"? I think the basic principle of new age is lovely, you know, "Let's get into another place with the world, a little more spiritual or a little more inner." That's real nice, but there's a lot of new age music that is so boring and meandering. I'm glad we're getting played a lot more, whether it's on new age stations, mellow jazz stations, or whatever. It's nice to get the band out. But I know I can't listen too long to some of the new age stuff. There's some nice stuff, but a lot of it isn't that musical.

SS: What does the future hold for Bill Berg the drummer?

BB: Well, playing more, hopefully with the BB's. I'm doing more active playing in L.A., and maybe I can bring my animation into the music. I still want to play, I want to do more writing, and maybe get into the electronic drum thing more—style my own sounds and stuff. But just play more. I'm really lucky to play with the guys I play with, and I hope it goes on as long as I'm around.



THOROUGHBRED MUSIC INC. THE MEN:



ag. Astoria

Dan

David Dief

THE EQUIPMENT:

An Unbelievable in-stock
PERCUSSION INVENTORY

ROLAND, L.P., TAMA, BEATO,
NOBLE AND COOLEY, SABIAN, DDRUM,
ZILDJIAN, GRETSCHE, R.I.M.S., PEARL,
SONOR, VICFIRTH, REMO, REGAL,
PROMARK, EVANS, & hard to find parts.

CALL FOR THE INDUSTRY'S MOST COMPLETE
FREE CATALOGUE

THE PHONE:



(813)

237-5597

THIS IS YOUR HOTLINE TO
THE SOUTH'S LARGEST
PERCUSSION INVENTORY.

STAY TUNED FOR EXCITING CLINICS
WITH THE HOTTEST DRUMMERS.

2204 East Hillsborough Avenue, Tampa, Florida 33610



VATER PERCUSSION

Quality Custom Label Drumsticks

STORE NAME'S AND LOGO'S

Tel. # 617-767-1877 FAX: 617-767-0010

PLEASE SEE CLASSIFIED

Photo by Lissa Wales



Paul

Sydney, just trying to make a living. I did sessions and demos—whatever was available.

I got this gig through the band's old bass player, Glen Krawczyk. Glen joined in '86 and was only with the band for a year. I used to play with him, and when Iva needed a new drummer, Glen recommended me. I gave Iva a tape and got an audition, and he liked the way I sounded.

TS: You joined Icehouse in 1986, and almost immediately were thrust into a live situation.

PW: Yeah, I joined right after *Measure For Measure* was recorded. They had used Steve

Janssen, of the band Japan. They finished the album around January, and I joined sometime in March and started rehearsing for the tour immediately. We came over here in support of that album. The single for that was "No Promises," and the follow-up was "Across The Border"; they both charted well. Of course, *Man Of Colours* was the real breakthrough for us over here.

TS: You've come far at a relatively young age. Do you think that's partially due to the thriving music scene in Australia? It seems that the club circuit there is extraordinarily active.

PW: It can be a good place to start. But you can get to a certain point there and then you've got to get out and move on. You can only reach a certain level in Australia. For example, Icehouse is the most popular band in Australia, but we pushed out beyond that to gain an audience in America as well.

The only thing that's really good about Australia is that you have to be good live to be able to go anywhere with your music. So since a lot of bands that come out of Australia have been playing around the country steadily, by the time they come overseas, they're a really great live band.

TS: Icehouse has been touring heavily since the release of *Man Of Colours* in mid-1987.

PW: Well, this tour has been going on for close to a year now, with a week or two break now and then. We've been over to America three times since we started.

TS: The playing benefits of such consistent touring can't be overlooked.

PW: I really enjoy playing a lot. In fact, I don't want a night off. When you have a night off and you're out or you're just sitting in your hotel room, you get really bored and you wish you were playing. I really

escaping textures that are at once soaring, spacious, electrifying, and robust, the music of Icehouse has an insidious habit of burning an indelible impression in your mind. At the same time, Icehouse is a rough and tumble rock 'n' roll band in the truest sense of the term.

Although they broke the American market in a big way with their fifth release, *Man Of Colours*, Icehouse had already achieved the distinction of being the biggest-selling rock band in their homeland of Australia long before the release of their latest LP. Their first attention-grabbing single stateside was '83's Roxy Music-inspired "Hey Little Girl." Moderate success followed throughout Europe and Great Britain over the next few years. But it wasn't until 1986's *Measure For Measure*—which spawned the hit "No Promises"—that Icehouse finally started drawing big audiences in America.

The follow-up, *Man Of Colours*, was released in mid-1987. Hits such as "Electric Blue," "Crazy," and "Nothing Too Serious" kept the album at the top of the charts for more than a year. Over a year of touring in support of the album made a solid case for the abilities of the band's drummer, Paul Wheeler.

Although *Man Of Colours* (Icehouse's first album to showcase the talents of a human drummer since their debut album) depicted Wheeler's sharp, tasty, polychromatic drumming, it was the international tour that established him as an exhilarating and adventurous player. Those gigs permitted Wheeler to unleash his adept improvisation, and it was at those rawer, looser moments that the band really exploded. "We're a lot tougher live than what people might expect," Wheeler affirms.

TS: Although *Man Of Colours* is a relatively straightforward album drumming-wise, one of your most shining moments is a cut called "Anybody's War."

PW: Yeah. That's the one where I get to get loose a bit. It starts off with sort of a mini solo that leads into the core of the song, and it ends up with a drum solo.

There are two other songs on the album where I really get to play what I want: "Nothing Too Serious," and "Sunrise," which is probably my favorite song on the record. They mirror my own style. Aside from those, a lot of the playing on the record came down to Iva [Davies, vocalist] and the producer telling me what they wanted me to play. I'm definitely a lot freer live, where it's a bit harder for Iva to turn around on stage and say to me "Don't play that." [laughs] I do what I like, for the most part, while keeping within the guidelines of the songs. It's more of *me* playing live vs. on the album. I'm happy with the way the album sounds; I just wish it could have had more of my ideas on it. But this was the first album I've done with Icehouse, so I think things will probably change in that area.

TS: One of the points of interest most focused on with this band is the high level of musicianship. You must have felt good about being asked to join such a reputable—and successful—band.

PW: Yes, I felt really good about joining the band because Iva is really fussy about musicians. He doesn't hire second-rate players. I'm not saying that I'm brilliant or anything....

TS: What were you doing prior to Icehouse?

PW: I was in a band called Machinations, who did fairly well in Australia. Before that, I played in small cover bands around

Wheeler

by Teri Saccone

love what I'm doing and I want to do it *all* the time.

TS: Speaking of playing, what are you using on stage?

PW: I used to use a Simmons kit. Now I'm back to an acoustic drumkit, which is good because I've always wanted to play a "real" drumkit with this band but haven't until the last year or so. I talked Iva into it, and I think he agrees that it's a lot better now.

I'm using a Yamaha 9000 Custom Recording Series kit; the rack toms are 8 x 10, 8 x 12, and 9 x 13; the floor tom is 16 x 16. The snare is a 9 1/2" brass Pearl. I also have a wooden one as a spare. But I really like the brass snare; it's got a good crack to it and it's really bright-sounding. The bass drum is actually a Simmons bass drum—an SDS9—and I've been using that with my real bass drum in front of it because it looks better than that plastic thing there. I'd prefer to use a real bass drum, but I'm still working on that. Actually, the Simmons isn't a bad-sounding bass drum, it's just that the dynamics on it are really fine and you've got to be hitting it really perfectly. If you hit it just a little too hard it will be too loud, and if you hit it just a little too softly it will be too soft.

TS: Do you use any sampled sounds with it?

PW: No, it's just programmed Simmons sounds. But like I said, it's a really good-sounding bass drum so there's no need to use sampled sounds with that.

TS: What about cymbals?

PW: I'm using Paiste: a 16" heavy crash, 8" and 10" splashes, an 18" crash, a 20" heavy crash, an 8" *Bell*, a 20" heavy ride, a 19" Rude ride crash, and a 20" *Novo China*. Most of those are the 3000 series; a few are the 2002's.

TS: What about devices of any kind?

PW: I play to a click track on every song live.

TS: Is that of your own volition?

PW: Well, we used to have a Fairlight on stage, but we had to get rid of that because the loading time between songs was something like 22 seconds, and that was too long. There'd be this big break between songs waiting for the count, and we'd stand there going, "Come on." So what we've

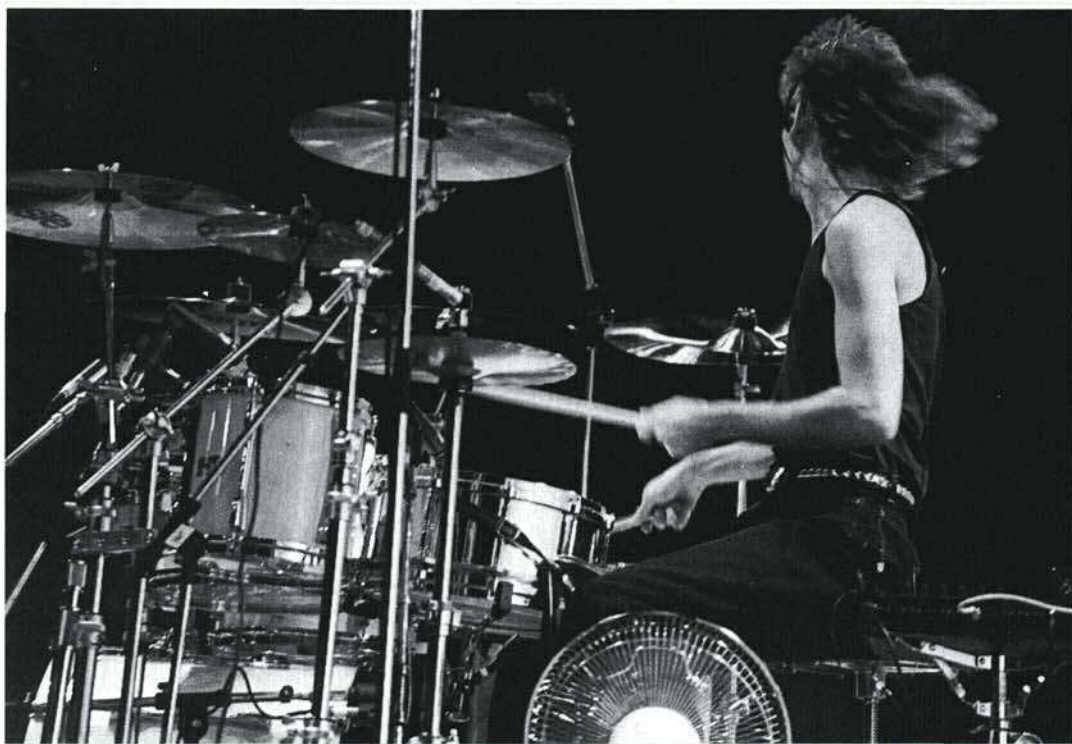

Photo by Lissa Wales

done now is put each song on videotape, so we just play them straight away.

TS: Could you elaborate?

PW: The videotape thing is just like recording something onto a cassette. We recorded what we had on the Fairlight—actually we dumped that onto an F1 cassette, which is just a videotape—and it then goes into this machine. You just press the play button, and you get all the things that we can't do on stage, like little percussion and keyboard parts. If we didn't have those parts, the songs wouldn't sound right. So I have to play to a click track on every song. I don't really mind; most of the time I don't even notice that I'm playing to it. I've been playing to it for so long that I sometimes find myself thinking, "Is the click track there?"

TS: You don't feel that you've come to depend on it?

PW: No, not at all. I mean, I'd prefer not to have to use it, but on the other hand, if I have to use a click, then that's okay, too. I like doing both.

TS: And it hasn't affected your playing in any way?

PW: It did at first, actually. When I first joined the band, I pretty much kept to what was done on the older albums, and now and then I'd throw something else in. I'm much more relaxed now. I think it's in the last year or so that I've started to do what I want to do live, without even realizing that

I'm playing to the click. Back then I was more wary of it—more concerned that I was gonna go out of time with it. I guess I was also being careful because I had just joined the band, and I didn't want to do anything wrong. Now I'm pretty secure, so I do more of what I want.

TS: What's your musical preference, drumming-wise?

PW: Well, I've primarily listened to rock and jazz/rock drummers. John Bonham and Bill Bruford are favorites of mine. In fact, I really like King Crimson a lot. And I'm really into Stewart Copeland—his delays, his hi-hat work, and his splashes. He sounded like he had about ten arms. Plus I really liked his drum sound.

TS: You have a technical side to your playing that isn't always apparent on record.

PW: There is a lot more to my playing than *Man Of Colours*. That's not the best indication of what my playing is like, except for the songs I mentioned. I am into the technical side of it, but I'm also into the feel of it as well. That's what made John Bonham what he was: He had a tremendous amount of feel behind his playing, and he had the technical aspect to it as well.

One thing that I'm sick of are all these bands with girl singers who all sound the same, with all this drum machine business—you know, all the top pop bands that you hear in the discos. When I hear that stuff I think to myself, "Why am I even

doing this when people are out there putting out these kinds of things that go straight to the top?"

TS: Do you concern yourself with the future of music?

PW: When I hear that stuff I start to worry a little. If it's like this now, what's it going to be like ten years from now? There are still good bands around, but a lot of people are just listening to that sort of stuff now.

Besides the fact that it's being fabricated by machines, the songs are mostly just rubbish. I don't listen to songs for the drumming so much anymore, with the possible exception of songs with drummers that I really admire on them. I listen to them more from the songwriting standpoint. When I hear a song, it's got to be a good

song before anything else. If there's really great drumming but it's not a good song, it's nothing really, is it?

TS: Do you dabble in songwriting at all?

PW: I haven't yet, but I want to. I just haven't had the time. Traveling around so much with the band takes up all of my time, and when I'm not playing, I'm too tired. But I want to get a little studio happening at home before I start writing. I want to get it set up properly so I can just go in when I have some free time and work on whatever. That way, whenever I get an idea, everything is already set up. I want to get into that very much, and I can see it happening soon. But right now, I'm more into the drumming side of things, obviously.

TS: One factor that seems to have played a major role in your success so far is your ability to be flexible. You're pretty laid back, but you're also very determined.

PW: I guess I am really flexible, yet I'm really confident. I've got a long way to go, though; I'm only 22.

TS: Your playing ability and your professionalism belie your youth.

PW: It's just that I've gotten a bit of experience since I've started. I've been lucky in that I've always found work. Yeah, I've definitely played with a few people, [laughs]

TS: It looks like you've got a long and prosperous career ahead of you.

PW: I hope so, but I don't want to say anything too definite, because I'm funny about that kind of thing—superstitious, I guess. I just take it as it comes.



LEARN TO MAKE MUSIC FROM THE PEOPLE WHO ARE MAKING IT

Drummers Collective offers you private instruction with great players like Rod Morgenstein, Mike Clark, Kim Plainfield, Ricky Sebastian, and Frank Malabe, each of whom has had years of playing, recording, and teaching experience.

We also offer regularly held small-group master classes with many top drummers such as Dave Weckl, Peter Erskine, Steve Gadd, Steve Smith, Gary Chaffee, and Kenny Aronoff.

There simply isn't a more comprehensive drum program available anywhere—we offer courses like:

- Afro-Cuban/Brazilian Rhythms for Drumset
- Studio Drumming
- Electronic Percussion
- Rock Drumming
- Theory and Ear Training
- Double Bass Drumming
- Polyrhythms/Odd Meter
- Rhythm Section Workshops

Ten Week Certificate Program

Classes are available on a short-term or long-term basis.

Plus Fully equipped practice facilities

So call or write for a free catalog and enrollment information.

DRUMMERS COLLECTIVE

541 Ave. of the Americas
New York NY 10011
(212) 741-0091



SONOR[®]
FULL LINE - FULL SERVICE
EXPLORERS
Percussion
Kansas City, MO
(816) 361-1195

**OUR STICKS ARE
GUARANTEED
STRAIGHT FROM
THE START!**

**THE GREAT AMERICAN
DRUMSTICK COMPANY**

With over
21 models to
choose from, find
out why Drummers from
all walks of life are telling us
that our 100% Great
American Hickory & Maple
drumsticks are the Best in
the Industry! Available at
Fine Music Stores
Everywhere!

**THE GREAT AMERICAN
DRUMSTICK COMPANY**

2315-B Forest Dr., Suite 7
Annapolis, Maryland 21401

(Dealer Inquiries Welcome!)

301/544-DRUM!

THE MD LIBRARY

MASTER STUDIES



by Joe Morello
The book on hand development and drumstick control. **Master Studies** focuses on important aspects of drumming technique.

THE NEW BREED



DRUM WISDOM

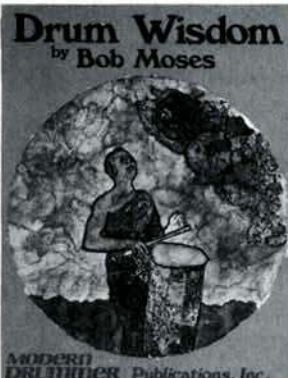

by Bob Moses
Here is a clear presentation of the unique and refreshing concepts of one of the most exceptional drummers of our time.

by Gary Chester
This is not just another drum book, but rather a system that will help you to develop the skills needed to master today's studio requirements.

NEW!
WHEN IN DOUBT ROLL!

The definitive book on the drumming of **Bill Bruford**
● Transcriptions of 18 of Bruford's greatest recorded performances, including his work with Yes, Bruford, King Crimson, and Moraz/Bruford.
● Bruford's personal commentary about each piece.
● Exercises written by Bruford to develop facility, flexibility, and creativity at the drumset.

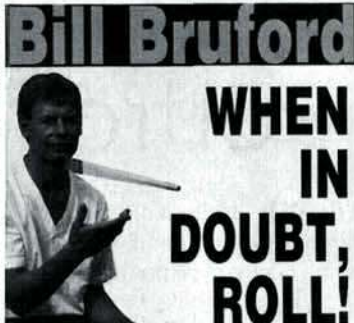

Transcriptions of Bruford's greatest performances, with Bill's personal commentary and suggested exercises

MODERN DRUMMER Publications, Inc.

CARL PALMER Applied Rhythms



Transcriptions of Carl's greatest performances with Emerson, Lake & Palmer and Asia, plus Carl's personal exercises for development of drumset technique.

MODERN DRUMMER Publications, Inc.

APPLIED RHYTHMS by Carl Palmer

Here are the drum parts played by one of rock's most legendary drummers. This book contains transcriptions of ten of Carl Palmer's most famous recordings, including "Brain Salad Surgery," and "Heat Of The Moment," and also includes Carl's personal exercises for drumset technique.

THE SECOND YEAR



Complete your MD Library with **Modern Drummer's Second Year**, a special reprint of Volume II: Issues 1-4

THE FIRST YEAR



Now you can have all four of the rare, out-of-print issues of Volume I: Issues 1-4 from cover to cover—even the original ads.

BEST OF MD, VOL. 2



This book is jam-packed with advice, concepts, and tons of musical examples, and offers a wide range of enlightening and timeless information, unavailable anywhere else.

IMPORTANT: TO ORDER *WHEN IN DOUBT, ROLL!*, *APPLIED RHYTHMS*, *MASTER STUDIES*, *THE NEW BREED*, *DRUM WISDOM*, OR *THE BEST OF MD, VOL. 2*. USE THE COUPON TO THE LEFT. TO ORDER *THE BEST OF MD, VOL. 1*, *THE FIRST YEAR*, OR *THE SECOND YEAR*, USE THE COUPON BELOW.

BEST OF MD, VOL. 1



Here are more than 75 of the most informative and helpful articles from our ten most popular *Modern Drummer* columns, written by some of our most popular authors!

NAME			
ADDRESS			
CITY		STATE	ZIP
QUANTITY	BOOK	PRICE	TOTAL
	WHEN IN DOUBT, ROLL!	\$12.95	
	APPLIED RHYTHMS	8.95	
	MASTER STUDIES	7.95	
	THE NEW BREED	7.95	
	DRUM WISDOM	5.95	
	THE BEST OF MD, VOLUME 2	7.95	
SHIPPING AND HANDLING			
GRAND TOTAL			
Make check payable to and mail to:			MOD 10
HAL LEONARD PUBLICATIONS			
PO BOX 13819, MILWAUKEE, WI 53213			
● Shipping and Handling: enclose \$1.50 for 3 books or less; Add 50¢ for each additional book			
● All checks or money orders payable in U.S. Funds only (no cash) ● Dealer inquiries invited			
● Please allow 6 to 8 weeks for delivery ● Books may be shipped separately			

NAME			
ADDRESS			
CITY		STATE	ZIP
QUANTITY	BOOK	PRICE	TOTAL
	THE BEST OF MD, VOLUME 1	\$9.95	
	THE FIRST YEAR	7.50	
	THE SECOND YEAR	8.50	
GRAND TOTAL			
Make check payable to and mail to:			
MODERN DRUMMER PUBLICATIONS, INC.			
ATTN: BOOK DIVISION			
P.O. BOX 469			
CEDAR GROVE, NJ 07009-0469			
● Prices include Shipping and Handling			
● All checks or money orders payable in U.S. Funds only (no cash) ● Dealer inquiries invited			
● Please allow 6 to 8 weeks for delivery ● Books may be shipped separately			

Portraits In Rhythm: Etude #18

I'd like to begin this month's column with some general philosophical thoughts regarding *Portraits In Rhythm*, and why I believe it's become so popular. Even though I've published a number of compositions since *Portraits In Rhythm*, they have not caught on to the same degree. I've pondered this situation over the years, and have come up with a few conclusions.

"Things"—books included—catch on because they fill a need and offer something unique to a very demanding and scrutinizing public. I've concluded that *Portraits In Rhythm* has done so well because readers have been able to identify with the etude's musical form. It's not that any one of the etudes are in any particular form; rather, they follow some principles of musical form that allow both musician and listener to relate to the ideas presented in a logical and practical manner. When considering the popularity of Western European music and its endurance over the decades, we notice a very strong element of musical form. I've based my etudes on similar principles, and believe this same success has applied to *Portraits In Rhythm*.

With this background information in mind, I'd now like to discuss Etude #18. I chose the foregoing analysis for this work because I stole (oops, borrowed) the idea from Offenbach's light opera, "Orpheus And The Underworld"; the borrowed selection is from the "Can Can" section, a popular dance of the late nineteenth century. The etude is not a direct quote; I've simply used the Can Can's form and style. It's not necessary for the performer to know this in order to execute the piece. If played properly, it will be conveyed by the rhythms and dynamics. However, what's really important is that the performer develop a sense of excitement and energy while playing.

Musical form creates a sense of organization for the listener. Themes return as old friends—they are welcome, familiar, and comfortable to be with. Variation increases interest and anticipation. Themes may return with a slightly different or drastic change, but should always have a sense of being familiar.

Observations

1. Begin the opening *fp* roll as a small explosion (as opposed to the lightness and crispness of the following 8th notes). As a performer, imagine the Can Can music; try to incorporate this same boisterous character.
2. Notice the staccato marks on the 8th notes. They indicate a short, dry stroke. Use a slight accent here.
3. The last three measures of line three begin with a series of loud and soft dynamics. These measures should be played closer to the center of the drum; move slightly off-center for softer passages (this will keep the sound consistent).
4. The *fp* in line four is a deceptive marking because both 16th notes are actually played at the *forte* level. As in the beginning, the *piano* begins on the staccato notes.
5. The pick-up notes into line six begin a theme starting on the upbeat. This theme conforms with the opening phrase (also an upbeat). Since the notes are tied over the bar line, the notation may seem a bit unusual. I usually don't recommend this notation, but have included it as a challenge. Be sure to phrase according to the notation. The natural accent comes on the upbeat and not on the downbeat. A simpler way of notating these measures is as follows:



Interpretations

1. Play the entire opening section near the center of the drum, moving slightly off-center for the staccato notes. I suggest the opening roll be played as a closed 5-stroke roll. To avoid unnecessary doubling into the rolls, try the following sticking pattern:



2. Observe the notation of the fourth measure of line six and notice the 8th-note roll tied to an 8th note, and then tied to another 8th note. This may appear to be an error, but it is not. Play it as a 5-stroke roll tied to the last 8th note of the measure. This 8th note is then tied to the first note of the fifth measure; in other words, it's not articulated. Think of the first note of the fifth measure as an 8th-note rest.

3. Separate the series of rolls beginning at the end of line eight, allowing each one to start, as written, with a fresh accent. The danger here is to end each roll with an accent. If this is done, additional notes not written are added. For best results, think of ending each roll with a slight rest before beginning a new one.

Scherzo $\text{♩} = 160$

The musical score consists of ten staves of bass clef notation in 2/4 time. The tempo is marked as $\text{♩} = 160$. The dynamics and articulations are as follows:

- Staff 1: *fp*, *fp*, *fp*
- Staff 2: *cresc.* ----- *f* *fp*, *f*, *fp*
- Staff 3: *f*, *ff*, *p*, *ff*
- Staff 4: *p*, *f*, *fp*, *fp*
- Staff 5: *fp*, *fp*, *fp*, *fp*, *f*
- Staff 6: *p*
- Staff 7: *pp*, *f*
- Staff 8: *pp*
- Staff 9: *fp*, *fp*, *fp*
- Staff 10: *cresc.* ----- *f* *fp*, *f*, *ff*

Music © 1968 Belwin Mills/Columbia, Hialeah FL. Used with permission.



What with all this talk of rimshots, you may want to get some rod-locking devices such as *Lug Locks* to keep the tension up on the head. I once recorded a reggae tune complete with dub echo. The snare, which was tuned way up and wide open, dropped drastically in pitch by the end of the track. The producer kept it on record to haunt me!

You'll notice that I haven't dealt at much length with sympathetic buzz and snare rattle. I feel that much of the appeal of a drumset, especially in the age of the sterile drum machine, is in everything humming along in sympathy—within limits. One thing that really bothered me when most of my recording projects were done in drum booths was that if I hit the bass drum or a tom-tom, the snares would sizzle. Actually, it didn't bother me, but I knew it attracted the attention of the engineer. It got to a point with some engineers where snares were taped to the bottom of the drum to quell vibrations. That particular means was forced on me in younger days, and I vowed never again. So what do you do to avoid the complaint that your snares are rattling too much?

If you've done everything you can, like adjusting the snare drum or altering the pitch of a particular tom to the point where you're happy, then do this: When the drums are all miked up and the engineer wants to do a drum check, odds are he'll say, "Can I have the kick, please?" Give him steady quarter notes but *keep your snare strainer*

off. Similarly, when you're asked for toms, keep the snares off. Only turn the snares on when you're asked to solo the snare drum, or to play some time. Sure, it sounds unethical, but the snares won't be rattling if they're not on, right? That way, you can sort things out during the course of the session if required. Chances are a few buzzes and rattles here and there will blend nicely into the track. If not, you can make adjustments along the way. The engineer has the liberty of doing it. So should you. At least things will get rolling, and your session won't grind to a halt because some drum is vibrating in sympathy with another.

Hi-Hats

It's not imperative for hi-hats to have the much-espoused killer "chick" sound. Oftentimes, to obtain that loud chick, manufacturers combine cymbals in weights otherwise found in ride cymbals. Here we can get into problems. The extra weight, while a boon on concert dates, can mean a certain sloppiness in the studio. Extra weight means extra thickness, and that extra thickness can mean a lot of excess clattering, especially when you're trying to play a delicate pattern with cymbals open an eighth of an inch. Rather than getting a nice sizzle sound, what the hi-hat mic' hears at its distance of 6" is an uneven *racket*. Heavier hi-hats lack the delicacy that may be required for certain jobs. They're slower in response and slower to mate when compared to a set of thin to medium weights.



POWERTOOLS.....

Touch Sensitive

No matter what style you play, heavy power metal, light trio jazz or somewhere in between, Tama makes a stick that feels great in your hands. Powertools offers 12 different models made of first quality American Hickory, matched in pairs and guaranteed straight. Treat your hands to the good life with Tama Powertools.

TAMA
BLITZ CLUB USA

For a Powertools catalog, send \$2.00 (\$3.00 in Canada) to Powertools, Dept. MDD1, P.O. Box 886, Bensalem, PA 19020 • 3221 Producer Way, Pennora, CA 91768-3916 • P.O. Box 2009, Idaho Falls, ID 83403 • In Canada 6969 Trans Canada Highway, Suite 105, St. Laurent Quebec, Canada H4T 1V8



NATURAL FEEL **DURABLE**

CONSISTANT & STRAIGHT

RimSHOT™ **THINK ABOUT IT**

RIMSHOT AMERICA VAN NUYS, CA 818 782-8848
IN CANADA: RODAM DISTRIBUTING LTD. 416 656-8462

Of course, there are exceptions. However, on the average session, it might be wise to stay with thinner models.

Yet another reason for this is that your hi-hats will be close miked, as is your snare drum. Leakage can be a problem, especially if you tend to lay into your hi-hats. It would be better to use a quieter set of well-matched hi-hats to reduce the possibility of too much hi-hat in the snare drum mic'. Taking this a step further, when that gated reverb is added to your snare in the mix, it won't be taking any hi-hat with it.

Thirteen inch, regular weight hi-hats work just fine. Hal Blaine used 12". One common practice these days is to use multiple sets of hi-hats. These sound nice when panned left and right in stereo, and you can employ one set for opening and closing sounds, and another for riding. There's another good reason for using an extra set. If you tend to have a heavy hi-hat hand, you might want to keep a set on an extension hi-hat on the opposite side of your kit, away from your snare drum mic'. That way you can flail away, secure in the knowledge that very little will leak into the snare drum mic'.

One last thing. I have a set of Sabian sizzle hats. The bottom cymbal has factory-installed rivets that impart a nice high-end boost to open and closed patterns. When I'm stuck for a good sizzle sound, I simply mount the bottom cymbal on a stand. If all that's required is a sizzle sound to tie a chorus into a piano solo, these work great.

**Now,
any
room
can
have
great
acoustics.**



DW Drum Workshop, Inc./2697 Lavery Ct., Unit 16/Newbury Park, CA 91320/805-499-6863

**SAY
YES
TO
DRUMS**

**with a
subscription
to Modern
Drummer**



**Call
Toll
Free
1-800-435-0715**

**Sam
Boland's
Super Gloss
Drum Material**

**Free
Samples!
Over 50 Colors!**

\$49.99

Super Gloss II Plus
(Black or White, 5 pc. sets,
other colors \$59.99)

Hours: Mon.-Fri.
Eastern 10-8
Central 9-7
Mountain 8-6
Pacific 7-5

Whether you have 1 drum
or 10,000, we have enough
to do the job. Why pay
more and settle for less?

We now offer a new space age
superior line of material called
"Super Gloss II Plus." It resists
heat incredibly well and is suited
for indoor and outdoor use.

Six years in business, now selling
technologically advanced space age
drum material to beginners, profes-
sionals, drum shops, studios, man-
ufacturers, and the world!

We Ship C.O.D.
Dealer inquiries welcomed.
(602) 279-4041



And you get three or four full seconds of sizzle.

Ride Cymbals

These are the cymbals on which a drummer registers his particular touch the most. And they carry the time. For me, the prime consideration for choosing a ride cymbal is just that—the time.

To give a musical example, you're reading a chart with two verses and a chorus. You're playing time on a closed hi-hat for the verses, but when the chorus comes around you move to the ride cymbal to open things up. What happens? The bottom falls out and the time *evaporates*. Why? Because your ride cymbal is washy and indistinct, and the metronomic ticking that

kept the verse moving is now lost.

Use a ride cymbal that can pass the test. Can you still hear the stick sound with fairly equal intensity when you go from closed hi-hat to cymbal? Remember, the engineer will require this sound off the floor. He's not going to want to boost the volume on the overheads just to hear your ride cymbal, because this will boost the level of your crash cymbals. If he does that, the game's over. All you'll hear are *cymbals*]

If you can't afford to purchase a new ride cymbal for your first demo session, get a roll of gaffer's tape and place a few strips on your ride, pretty much anywhere. Most drummers put it along the underside, avoiding the extreme edge. I put it on the playing side where I can see it and adjust it.

Don't use masking tape. If you forget and leave it on for a few weeks, it glues itself to the cymbal. The use of tape sounds blasphemous to a cymbal purist, but it works in a pinch.

If you have some money, you'll find that most companies make really acceptable rides that will work in the studio. The trick is to get definition, but not *too* much. Without a little wash behind that ping, things can sound a little too metronomic, not to mention what happens when you monitor through an average car speaker. This means staying away from super thick cymbals. Ordinarily, I'd go with something in a medium to heavy weight, and probably 20". Too large, and the average drummer might find problems proportioning the sound.

I've enjoyed using Sabian *HH's*, and I find that the overtones are not so high-pitched as to clash with the upper register of the piano, or guitar harmonics. When they do build up, the wash is of a low frequency and fills a space the producer is more willing to yield to you. He doesn't want a stinging ping sound wiping out half of his instrument mix.

Zildjian K's also work well. Paiste's *Formula 602* cymbals have this characteristic as well—a slightly more gentle sound without a preponderance of high-end shrillness, while retaining lots of stick. And use a cymbal with a nice clear bell. I have one otherwise beautiful ride that sports a bell so piercing it will take your head off. Save that sort of cutting power for live gigs.

It's also very important to play your ride cymbal *consistently*. There's nothing like a studio playback to alert you to your deficiencies. I thought straight 8ths on a ride cymbal were a snap. The other day, while listening to a take, I was absolutely embarrassed to hear that I was under-sticking every second note during a steady ride section. Sure enough, the section was played in time, but instead of hearing notes of equal intensity as I thought I was playing, it sounded more like a shuffle—clearly *not* my intention. Correcting the uneven sticking for the next take, the song regained a steadier pulse and took on a brighter pop feel.

Along the same lines, you may want to simplify your cymbal patterns, at least on the ride. I've found that some of the players I religiously copied frequently employed quarter-note ride patterns instead of 8ths. The cleaner your pattern, the easier it is for the mic' to understand it. Ultimately, the track will sound much better.

Crash Cymbals

If there is the notion of tension/release in the cymbal family, then ride cymbals are the tension—the insistent time keepers with rare swells hinting at what's to come—and crash cymbals are the release of those swells. I've found the need to restrict my use of crash cymbals on recording sessions.

I'm convinced that for the average recording date, it's better to carry smaller, thinner crash cymbals. Dave Mattacks, a

TODAY'S SOUNDS PUT NEW IDEAS INTO OUR HEADS.

Take a look—and listen! Whatever your choice in sound, Remo has the Sound Choice. Today's tom tom sound is Remo Clear Emperor—big, open, resonant and tough. For today's crisp, dry snare drum sound, it's the Remo CS Coated (with Black Dot underneath). And, try our PinStripe Coated bass drum head—solid and warm with superb projection—along with our full range of PinStripe batters that have become the standard around the world. Drum heads by drummers, for drummers. The Remo difference.

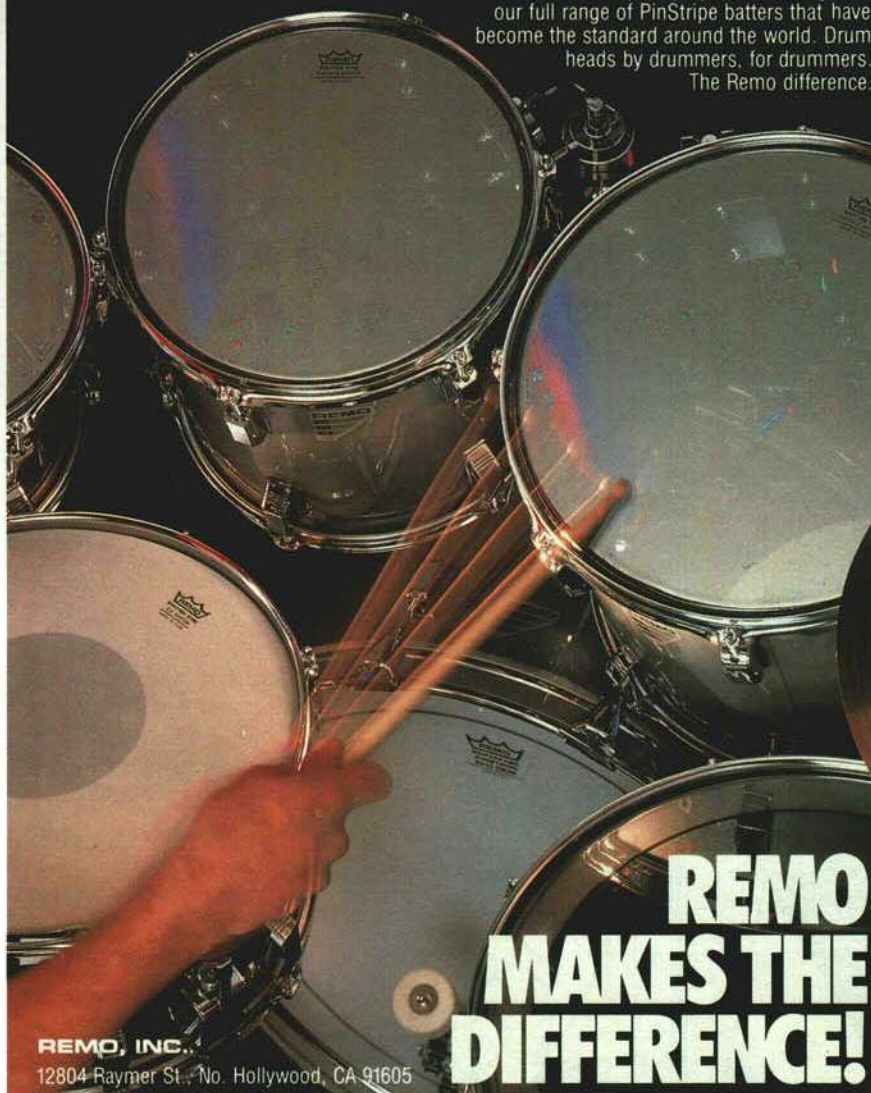

REMO MAKES THE DIFFERENCE!

REMO, INC.
12804 Raymer St., No. Hollywood, CA 91605

virtual *master* of cymbal choice and recording technique, showed me something about choosing cymbals for studio use. Narrow your choice of small, thin crashes to three or four. Always strike with the same stick you intend to use on dates. Then, hit the cymbal softly and pause with your ear in close proximity, just where a mic' would be positioned. Listen carefully for hints of low-end rumble. Oftentimes, perfectly good crashes will exhibit a sort of *drone* in the lows and mids—something like a small engine humming or a cat purring. This characteristic doesn't invalidate the cymbals as crash cymbals. Just don't use them in the studio. You can be sure that any stray overtone you hear in the music shop will be *twice* as obvious in the clinical recording environment.

Where on a fairly loud live date you would want a 16" and an 18" crash, you might be content in the studio with a 14" and a 16". I have a collection of 14" crashes, all of which sound a little "thinnish," but which seem amazingly huge when run through overhead mic's. But my favorites are probably 15's. They're large enough to lessen the sometimes vaudeville character a 14" can suggest, yet still offer the benefits of small cymbals. They rise and decay quickly, and the pitch is high.

We've all seen the ads showing drummers with 12 crash cymbals. That's fine, if you can reach them, know how to choose them, and are set up in a large enough room for all that sound to disperse properly. For the most part, however, you'll want a couple of cymbals with very distinct pitch differences. One crash will be panned left in stereo, the other right, so there's little sense in having the same sound back at you from both angles. I also suggest keeping at least one crash with a low, fat sound. I have a 20" old K, and I've never regretted that purchase. It's a very thin, dark cymbal that can be used to signal the arrival of a minor passage in the chart.

These days, you can get the same sounds from various companies, all of whom make hand-hammered cymbals, from Sabian *HH's* to Zildjian *K's* and Meinl *Dragons*. Again, there's no rule saying all your cymbals must be the same make for studio work.

In regards to Chinese cymbals, these are so eccentric and personal, there's not much I can say except for two things. First, they make nice rides when played softly, backing a smoky sax solo. Second, they sound *twice* as good when placed normally on the stand with the bell facing up. I've noticed a marked increase in bottom end, which is what you're looking for in a China cymbal when they're suspended right side up. If, on the other hand, you want that "shotgun" sound, then place it upside down.

Suspending Cymbals

Suspending cymbals in the studio is much more critical than in live performance. If you can manage it, avoid putting them at

Take Your Snare Sound To The Next Level With Compo Heads!

Discover the reason many of today's top touring drummers have come to depend on the consistent sound and performance of Compo Heads. Put a Compo Head on your favorite snare drum and experience the latest technology in drumhead manufacturing, utilizing man-made multifabric blending and Compo's patented weaving technique.



Tico Torres with *Bon Jovi* plays *Attack Series A4XC14 Snare Batter*.



Moyes Lucas with *George Michael* plays *Studio Series S4YC14 Snare Batter*.



Carl Allen *Jazz Master* plays *Natural Series N3RC14 Snare Batter*.



Dony Wynn with *Robert Palmer* plays *Custom Series N4XC14 Snare Batter*.

You can find Compo Heads at leading drum shops nationally, or just write to Compo, c/o Kaman Percussion Team, P.O. Box 507, Bloomfield, CT 06002 and we'll send a list of dealers in your area and the '89 Compo Catalog/Price List.

KAMAN



CRD

JONATHAN HAAS

Virtuoso Timpanist

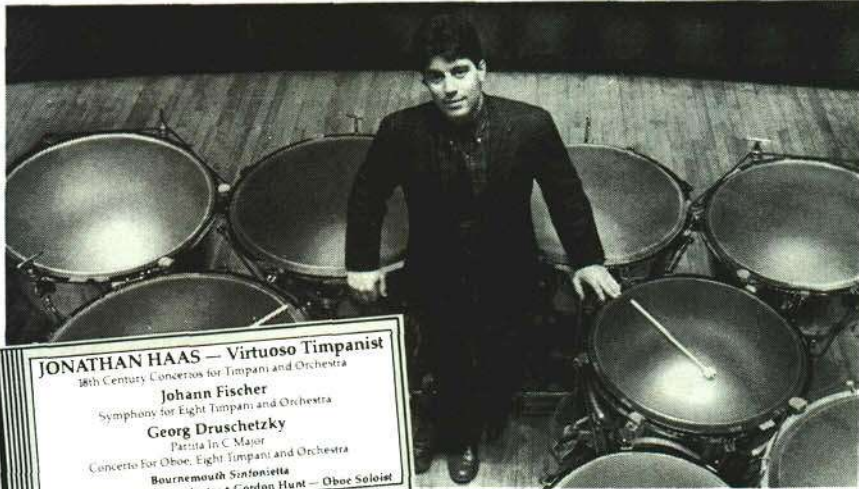

NEW RELEASE

18th Century Concertos

Compact Disc — CRD 3449CD or
on Cassette — CRDC 4149TC

Available at fine stores nationwide. Free catalogs upon request.

QUALITON "Imports of Distinction"

24-02 40th Avenue, Long Island City, NY 11101 • 718-937-8515

extreme angles. The increased tightening of the wingnut and tilter angle will choke much of the natural vibration. Cymbals sound their best when placed flat on the stand, parallel to the floor. They vibrate freely and transmit and receive fewer overtones to and from the stands.

Try to place your cymbals in an even line a foot or two below the overheads. This is a measure you can take on the floor to ensure that a proportionate representation of each cymbal will be attained. Another thing I try to do is position the cymbals as *high* as possible. I know I'll get many an argument here, but the idea is to keep the cymbals from bleeding into the drum mic's, ensuring a more discrete cymbal mix. But don't try anything too radical. After all, you've got to be able to *reach* the things without upsetting the time, or getting a hernia, both of which I've managed more than once!

Minor Precautions

Before that first big session, get some rubber tubing and cover the center rods of your cymbal stands. Cymbal sleeves wear away fastest on the side facing away from you—the side you're least likely to see. Replace them all before recording and you'll minimize metal-to-metal contact. And put a strip or two of gaffer's tape around those large metal washers on which the cymbals sit. Tape them up and cover them with a generous piece of felt. They'll make them-

Grab a stick quick!

The "Stick Depot" holds drumsticks in perfect position . . . out of the way, yet ready when you need them.

Clamps easily to a hi-hat stand, floor tom, cymbal stand, etc. Right where you need it.

Chrome tubes are easily adjustable to desired angle.

Another innovation from
pro-mark
Our reputation is in your hands.

Stick Depot

Keep sticks out of the way and right within reach.

See your local dealer or send \$8.00 each to Pro-Mark, 10707 Craighead Dr., Houston, TX 77025. Send \$2 for new color catalog.

FAST ACTION TUNING KEY

Indispensable new tool for drummers.

"Ratch-It" action means fast tuning, quicker replacement of drumheads & speedy hardware adjustments. A must for serious drummers.

- Handy combination Phillips/slotted-head screwdriver attachment makes it easy to deal with minor emergencies.
- Includes 3-position ratchet selector switch.
- Stores conveniently in your stick bag.



Another innovation from
pro-mark
Our reputation is in your hands.

See your local dealer or send \$15.00 each to Pro-Mark, 10707 Craighead Dr., Houston, TX 77025. Send \$2 for new color catalog.

selves heard otherwise.

Finally, there's a sort of phasing effect that is noticed when recording cymbals, especially crashes. The necessary rising and falling of each side of the metal plate produces a concomitant rising and falling of pitch, which translates into an undulating sound. There's not much to be done here. If you tighten the wingnut, you'll reduce the offending motion of the cymbal, but you'll get less crash and a stifled sound. I've found that a combination of suspending the cymbal flat and hitting it consistently can control this ship-at-sea motion somewhat. There's a certain knack to giving a cymbal a good blow without sending it reeling. My engineer also advises that small diaphragm overheads reduce the swishiness at close proximity. The key here is *close*. At 25 feet, who would notice the phenomenon at all?

And so it goes with drums and cymbals on recording dates, be they demos or jingles. A whole catalog of items, not entirely relevant to club-date drumming, becomes your checklist. Do your homework before that important recording. Checking washers and sleeves, solving annoying buzzes in that 42-strand snare assembly, and replacing that rock crash with a thin splash are all things that eat up less time in the studio. More importantly, they leave you and your fellow musicians more time to *create music*.



R I M S H O T S

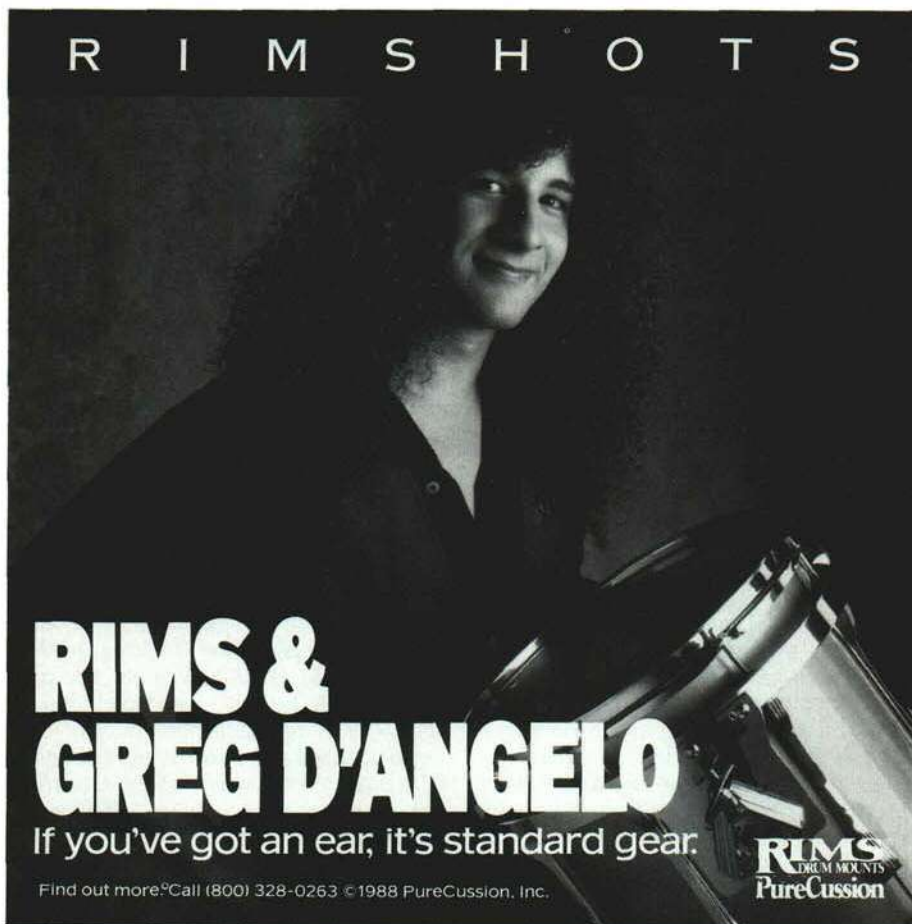

RIMS & GREG D'ANGELO

If you've got an ear, it's standard gear.

Find out more: Call (800) 328-0263 ©1988 PureCussion, Inc.

RIMS
DRUM ACCESSORIES
PureCussion

THE LARGEST DRUM SHOP IN THE WORLD HAS THE SMALLEST PRICES.



**WE BEAT PRICES NATIONWIDE!
CALL US AND WE'LL PROVE IT TO YOU.**

BE SURE AND ASK FOR OUR TOLL-FREE ORDER NUMBER.

1-713-781-DRUM

5626 SOUTHWEST FRWY. HOUSTON, TX 77057



Electronics On A Budget

For years I had wanted to get into the exciting world of electronic drumming, yet like most young drummers of moderate income, the expense was just too great. After a number of profitable gigs, I decided to invest some of my earnings and put an end to my suffering! I had spent most of my time comparing the different manufacturers' products, and figuring out how to get the most for my dollar. This is the only *good* thing that comes out of "not having the money," though I recommend spending this time even if you *do* have the money.

An important consideration when buying electronics is what kind of musical environment you're playing in. My band is a blend of Top-40 and oldies, so I wanted a system that would allow me access to a variety of sounds, and be flexible enough to grow as I was able to afford more equipment. Obviously, MIDI is a must, unless you're on an extremely strict budget (though even non-MIDI devices can eventually be incorporated into a MIDI system).

I found that the Simmons *TMI* was the ideal piece of equipment for me at the time (though all of the suggestions I will make can be put to use with any trigger-to-MIDI controller on the market). The *TMI* is a pad-to-MIDI converter that has eight channels. Up to eight pads can be used at once, each with its own sensitivity control and each able to transmit on its own MIDI channel. Through a lack of communication with the shop owner, I ended up with just the brain, and no trigger pads. The unit cost almost \$400, yet it was useless to me by itself. With a little creativity, a little more money, and some help from my friends, I now have a system that rivals a \$2,000 setup. Here's how you can do the same.

You should take into account what MIDI instruments are owned by other members of the band, and find out if you'll have access to them. The system I described above is just a MIDI controller; it makes no sounds of its own. However, I bought it knowing that my guitar player had a drum machine, and that my keyboard player had two drum machines and a sampler.

My guitar player's drum machine was being used at the time for home recording only, so he didn't mind letting me use it on stage. In this way, I was able to add percussion and effects to my setup.

My bandmates wanted to know why I would bother getting the unit without the trigger pads. I told them not to worry. Luckily I had remembered a great article in the December '85 issue of *MD* called "Drum

Pickups" that described how to make your own pads. It tells how a simple piezo buzzer (Radio Shack catalogue #273-064) can be turned into a drum pickup. By simply taking the buzzer out of its case, replacing the wires with sturdier cable, sealing the assembly in rubber or glue for strength, and connecting the other ends to the appropriate jack or plug for your unit, you can turn anything into an electronic drumpad. This can also be used as a trigger/pickup if mounted directly on a drumhead. I bought the necessary parts, and quickly converted one of my old metal Ludwig practice pads into a usable trigger. I also purchased an accessory clamp, attached my pad to a cymbal stand, and a few hours later gleefully pounded my way into the electronic age—thanks to the help of my MIDI friends. A mounting clamp can be bought for about \$10, and practice pads range from \$15 to \$25, depending on the size. The electronics can be put together for less than \$5, making the grand total \$40 or less per pad. That's less than one third the cost of buying the equivalent from a shop. If you already have a pad or two, then all you need to buy are the electronics and the mounts.

Later that week I found two friends who had practice pads from grade school, and got two more free pads to add to my set. A few months later I dug up the original bass drum pedal that came with my current set, and bought one of those electronic trigger/converter plates (like the one made by Drum Workshop). I ended up with a complete four-piece set, without any actual pads from a manufacturer.

Of course, the *TMI* can handle eight pad inputs. I was not happy knowing that four more sounds were so close yet so far. So, I thought of a way to get more out of my MIDI converter. I had an adapter plug that has two female 1/4" inputs on one end and a single 1/4" male plug on the other (also available at Radio Shack, catalog #274-309). I plugged one directly into each of my pads and ran *two* cables to the *TMI*, achieving instant sound layering for the price of an adapter and another cable!

Only high-end units, such as Yamaha's *PTX-8* and Simmons' *MTM*, normally allow such an effect. Even the cheapest drum machine sounds are more impressive when they're layered, and I can set the sensitivity control on one of the channels so the "second" sound only comes in when I strike harder. Thus, each of my four pads can now trigger two sounds, if I so choose, and not one available input is going unused.

This trick is guaranteed to work on any pad-to-MIDI-type controller, because the unit reads the input signals as if they're coming from two different pads that are struck simultaneously. To achieve greater control over this effect, you can purchase an A/B box, which has one input and two outputs with a switch to choose one or the other, or both. In this way, you can turn the "second" sound on or off. These boxes aren't cheap, however, so this might work against our budget-conscious approach.

If you don't know anyone with MIDI devices, fear not! As with all things electronic, the price of first-generation drum machines is falling rapidly. Rhythm boxes that were once almost \$600 are now in the \$200 range. Of course, they aren't as versatile and realistic as this year's models, but they'll be good enough to get you started. Buying used gear is often your best bet, since the seller is as excited about getting a newer model as you are about getting your first. Remember, you can always upgrade later. Right now you just want to join the rest of the electronic drumming community.

Another approach is to get an old analog set, such as those made by Simmons, Pearl, and Tama. The sounds these units make have become dated, but for a few hundred dollars you can own a set that originally cost over a thousand. Once you have that set, you can start saving for a MIDI controller, some of which will let you access your old analog set from the same pads.

One last issue is a reverb unit. Reverb has a way of making even the most pitiful drum box sound impressive. (When buying electronic drums or drum machines, always ask to hear them without reverb first.) While professional-quality reverb units aren't cheap, a decent one can be had for less than \$200. Amplifier or P.A. reverb can give your electronics a little extra *oomph*, and you *will* need some kind of amplifier now that you've entered the electronic age. See if you can claim an unused channel on the band's P.A. until you can afford an amp of your own. Again, you may find that another musician might have such a unit for home recording that you may be able to borrow. Eventually you'll want a professional-quality unit with MIDI control options, maybe even before you buy a more sophisticated sound source. Sometimes it seems that once you get started buying electronic equipment, there's no stopping. But don't despair over your small bank account. Getting started is the best part!



MODERN DRUMMER PUBLICATIONS BACK ISSUES

- #63—JANUARY 1985**
Alan White, Shelly Manne, Ollie Brown, Nick Mason.
- #64—FEBRUARY 1985**
Mel Lewis, Mark Brzezicki, Mick Avory, Inside Meinl.
- #65—MARCH 1985**
Roger Taylor (Duran Duran), English Reggae, Jon Von Ohlen, Inside Premier.
- #66—APRIL 1985**
Sly Dunbar, Steve Schaeffer, Chico Hamilton, Getting Your Drum Book Published.
- #67—MAY 1985**
Alan Dawson, Steve Ferrone, David Robinson, D.J. Fontana.
- #68—JUNE 1985**
Steve Jordan, Drum Equipment: A New Look, Mickey Curry, Jerry Allison.
- #69—JULY 1985**
Rod Morgenstein, Kenny Malone, 1985 Readers Poll Winners.
- #70—AUGUST 1985**
Larry Mullen, Jr., George Grantham, Inside Sonor.
- #71—SEPTEMBER 1985**
Jeff Watts, Vinny Appice, George Brown.
- #72—OCTOBER 1985**
Chris Parker, Chris Slade, Drummers In Atlantic City.
- #73—NOVEMBER 1985**
Bernard Purdie, Bobby Chouinard, Ed Soph.
- #74—DECEMBER 1985**
Tony Thompson, Nicko McBrain, Paul Wertico.
- #75—JANUARY 1986**
MD's 10th Anniversary Issue, 1st MD Sound Supplement: Studio Drum Sounds.
- #76—FEBRUARY 1986**
Roy Haynes, A.J. Pero, Jimmie Fadden, David Calarco.
- #77—MARCH 1986**
Jerry Marotta, Marvin Smith, Manny Elias, Buddy Williams.
- #78—APRIL 1986**
Ed Shaughnessy, Don Baldwin, Jerome Cooper, Ray McKinley, Ted McKenna.
- #79—MAY 1986**
Craig Krampf, Terry Williams, Armand Zildjian, Alex Cooper, Bud Harner.
- #80—JUNE 1986**
Kenny Aronoff, Adam Nussbaum, Joe English, Doane Perry, MD Sound Supplement: Focus On Hi-Hat by Peter Erskine.
- #81—JULY 1986**
Billy Cobham, Tico Torres, Jeff Hamilton, Readers Poll Results.

- #82—AUGUST 1986**
Steve Smith, Bill Gibson, Joe Franco, Terry Bozzio: Style & Analysis.
- #83—SEPTEMBER 1986**
Tommy Lee, Bun E. Carlos, Jerry Carrigan, Ben Riley.
- #84—OCTOBER 1986**
Dave Weckl, Bobby Blotzer, Debbi Peterson, Staying In Shape: Part 1.
- #85—NOVEMBER 1986**
Joe Morello, David Uosikinen, Barriemore Barlow, Staying In Shape: Part 2.
- #86—DECEMBER 1986**
Simon Phillips, Dave Holland, Industry Insights With Remo Belli, **MD 10-Year Index.**
- #87—JANUARY 1987**
Gregg Bissonette, Gary Husband, Rod Morgenstein Sound Supplement.
- #88—FEBRUARY 1987**
Anton Fig, Connie Kay, Jerry Kroon, New York's High School Of The Arts.
- #89—MARCH 1987**
Graeme Edge, Joe Smyth, Blues Drummers: Part 2, Inside Pro-Mark.
- #90—MAY 1987**
(Without Sound Supplement)
Vinnie Colaluita, Stan Levey, Music Medicine.
- #91—JUNE 1987**
J.R. Robinson, Lars Ulrich, Ricky Lawson, Inside P.I.T.
- #92—JULY 1987**
Peter Erskine, Anton Fig, Drummers of West Germany, Close-up on Drumsticks.
- #93—AUGUST 1987**
Buddy Rich Tribute, Mike Baird, Tom Brechtlein, 1987 Readers Poll Results.
- #95—SEPTEMBER 1987**
Rick Marotta, Steve White, Gary Burke, Reminiscing with Bill Ludwig.
- #96—OCTOBER 1987**
Narada Michael Walden, Al Jackson, Neil Peart Contest Results, Dave Weckl Sound Supplement.
- #97—NOVEMBER 1987**
Randy Castillo, Curt Cress, Christian Drummers: Part I.
- #98—DECEMBER 1987**
Manu Katche, Steve Houghton, Drumming At Disney World, 1987 MD Index.
- #99—JANUARY 1988**
Phil Gould, Richie Morales, Chick Webb, Drumming & Relationships.
- #101—MARCH 1988**
Rick Allen, Richie Hayward, The Graceland Drummers, Stryper's Robert Sweet.

- #102—APRIL 1988**
Danny Gottlieb, Alan Childs, The Downtown Drummers, MD Visits Drummers Collective.
- #103—MAY 1988**
David Van Tieghem, Bill Berry, Charlie Benante, The Cavaliers.
- #104—JUNE 1988**
Tommy Aldridge, Ralph Humphrey, Luis Conte, Drummers in the Business World.
- #105—JULY 1988**
Liberty Devitto, Ron Tutt, Carlos Vega, Mick Brown, Greg Bissonette Sound Sheet.

MODERN PERCUSSIONIST MAGAZINE

- #1—DECEMBER 1984**
Gary Burton, James Blades, Brazilian Carnival, Marty Hurley.
- #2—MARCH 1985**
Emil Richards, Bobby Hutcherson, Carol Steele, Ralph Hardimon.
- #3—JUNE 1985**
Nexus, Dale Anderson, Fred Sanford, Ray Barretto.
- #4—SEPTEMBER 1985**
Ralph MacDonald, Garfield Cadets, Chris Lamb, Guatemalan Marimbas.
- #5—DECEMBER 1985**
David Friedman, Jimmy Maelen, Karen Ervin Pershing, Jay Wanamaker.
- #6—MARCH 1986**
Star Of Indiana, Ray Cooper, Fred Hinger, Earl Hatch.
- #7—JUNE 1986**
Mike Mainieri, Repercussion Unit, Tom Float, Ray Mantilla.
- #8—SEPTEMBER 1986**
Manolo Badrena, Keiko Abe, William Kraft, Ward Durrett.
- #9—DECEMBER 1986**
Dave Samuels, World Drum Festival, Ken Watson, D.C.I. Solo Contest.
- #10—MARCH 1987**
Doug Howard, Reggae Percussion, Jim Jones, Creative Careers.
- #11—JUNE 1987**
Spirit Of Atlanta, Dave Samuels Sound Supplement, Triok Gurtu, CalArts.
- #12—SEPTEMBER 1987**
Milt Jackson, Sue Hadjopoulos, The President's Percussionists, Al LeMert.

Check off the issues you desire above and send in the entire ad. All back issues are \$4.00 each (this includes postage and handling).

Total issues ordered _____ My payment for \$ _____ is enclosed.

NAME _____

ADDRESS _____

CITY, STATE, ZIP _____

Mail check or money order
(no cash) in U.S. funds to:
**MODERN DRUMMER
PUBLICATIONS, INC.**
Back Issue Service
870 Pompton Avenue
Cedar Grove, NJ 07009
Allow 6 to 8 weeks for
delivery

DENNIS CHAMBERS

Regal Tip Sticks

Dennis' incredible jazz-funk drumming is responsible for his growing reputation as one of the most outrageous young drummers around. Yet, no matter how nasty his groove is, his "bad" player always grabs hold of some good wood.

"I've played just about every stick there is, but for me, Regal Tips work the best. They always feel great and they last. That's why I believe in them."

Regal Tip's NEW 8A

Regal Tip Drumsticks are made only from hand-selected, 100% American hickory. Grab hold of a pair and feel the difference. Available at better music stores or write for free catalog.

REGAL TIP

calato USA
4501 Hyde Park Blvd.
Niagara Falls, NY 14305
716-285-3546



IT'S QUESTIONABLE continued from page 14

concerned with is condensation that can form on cold metal surfaces due to changes in temperature.) You would be wise to allow your cymbals to warm up a bit before playing them if they are extremely cold. Cymbals that have been stored for some time at several degrees below zero could possibly become more brittle than they would be at normal "room temperature," and it would pay to be cautious.

Wood drumshells are more subject to damage due to temperature shifts, simply because wood is an organic material and will expand and contract to a greater degree than will metal. As you surmised, there is more risk from shifts in temperature than from a consistently low temperature. Our suggestion would be to not keep the drums set up all the time. Leave the stands, hi-hat, seat, etc. set up, but keep the drums in cases—preferably foam-lined for additional thermal protection. If you don't have such cases, pieces of old blankets make excellent linings for plain cases or drum bags. If you have no cases, obtain cardboard boxes of adequate sizes to contain each drum wrapped in a layer or two of blanket. Try drumshops or furniture stores for boxes large enough to hold the bass drum and floor toms. The amount of time that you lose in putting the drums on the kit before practicing, and putting them away again afterwards, will be more than justified by the amount of protection you are affording your drums. This should keep them in good condition and ready to go to work for you when the opportunity presents itself.

If you plan to leave your drums in this storage facility during warmer parts of the year (i.e., other than the school year), be sure that it is suitably ventilated. Remember that an enclosed space can build up internal heat quickly, even when the outside temperature is only in the 70's. Overheating is as much or more of a threat to your drums as is intense cold.

READERS' continued from page 6

ther pedal has squeaked since.

Perhaps other owners of this otherwise marvelous pedal might find this tip useful. More importantly, if the problem is simply at the heelplate point, perhaps a minor design change from Ludwig could totally eliminate the problem forever for all of us. Now wouldn't that be nice!

J.D. Martin
Omaha NE

GIVING SOMETHING BACK

I have been reading your publication as long as I can remember, and one area that I enjoy—and have learned much from—is your *Readers' Platform*. After playing for 17 years—ten as a professional—I experienced something recently I never thought I would, and I'd like to share it.

Many years ago, before I had talked my parents into a "real" drumkit, I would take every opportunity I could to see someone play the drums. (I still do.) I would sit and watch their every move, and be fascinated! I would study their equipment and dream of someday playing on real drums, in a real band, and on a real stage. It didn't matter if they were in an arena or a Holiday Inn; I had all the respect in the world for them—and a certain amount of awe. If given the chance, I would make any excuse in the world to talk to them, and maybe get some pointers. Whether they were great players or just so-so, I was still fascinated by the fact that "they were doing it!"

Recently, I was pulling a sit-in job with a local C&W band. The band was nothing to write home about, and the fact that I was not that familiar with their material did not give me a chance to really relax and show my ability. But all through the night, I noticed a boy of maybe eight or nine watching my every move. On my first break, he must have walked by me 20 times. On my second break, he came up to ask about my kit and where he could get one, and about how long it took me to be able to play like that.

I was tired, frustrated, and I wanted to be anywhere but there. But something flashed back to me: a short, pudgy kid who loved to bug drummers! So I answered all his questions, bought him a coke, and let him sit behind my kit. And when he asked me to sign the stick I gave him, I was blown away!

Remember, folks: It wasn't that long ago for you! Help keep the magic of our art alive by building on the dreams and goals of our "future drummers."

Darron Henderson
Co-owner, Kansas City Drumworks
Kansas City KS

"MY MAN IN DALLAS."

HENRY OKSTEL

DOUBLE BASS MODEL NO. 6

45 models available

FREE CATALOG

"Set-the-Pace" PEDAL PRACTICE PADS
Ralph C. Pace
Box 63 NO, North White Plains, N.Y. 10603

ddrum[®] 2

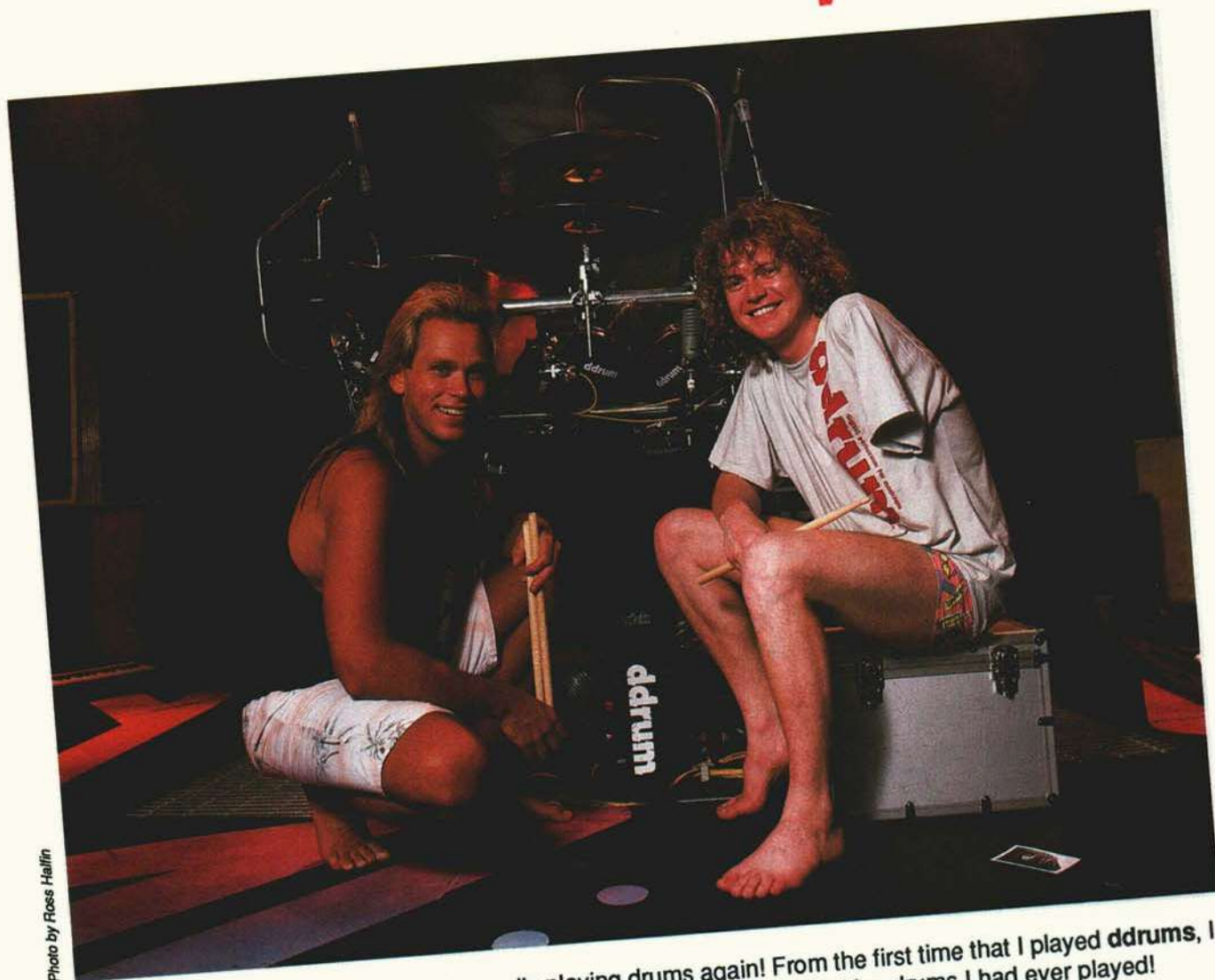

Photo by Ross Hallin

Now I'm really playing drums again! From the first time that I played ddrums, I knew they were the most dynamically sensitive drums I had ever played!

Rick Allen
DEF LEPPARD

Best Pads! Best Sampling! Best Appearance! What more can you ask for!

Ian Haugland
EUROPE

by Craig Krampf

On Professionalism

There's been an underlying theme running through my articles, and I'd like to make a point of it before we move on to other areas. As we've seen, recording situations will always vary. But through it all, we need to remain *consistent* and *passionate* about our work. These are two qualities that are essential, not only as part of a good work ethic, but as an important part of the way we live our lives.

To be consistent, elements of compatibility are brought into play. In the recording world, this means we must be capable of adapting to the situation, and perform with a good attitude. You can never be quite sure what you're in for when you open that studio door, and regardless of what awaits you there, you must be ready to fulfill what the situation dictates—and *willingly!*

A friend of mine is doing an album project in which the producer is having everyone play at the same time, but he's only keeping the drum tracks. The guitars, bass, keyboards, and vocals are only for reference. This producer is trying to capture an emotional drum performance, even though the drummer is playing with musicians who know their parts are not being kept. As a re-

sult, they're not really playing their hearts out. In this instance, the drummer has got to *dig* a little deeper to get ready for an emotional performance. He has to adapt to the producer's process, and must be willing to do it this way even though he may not agree with the method. This is what's expected of you if you're a true pro—to do what *they* want, and with a good attitude.

Years ago there were notorious stories about Bee Gee recording sessions. The Gibb brothers would spend days getting the bass drum sound just right. When they had it on tape, they'd move on to the snare, hi-hat, and cymbals. They would literally keep only one limb of a drummer at a time! This may sound weird, but who can knock their method? They sold millions of records, and the drummers had to adapt.

Sometimes when tracks that are cut with machines are almost completely finished, the producer or artist decides that acoustic drums might sound better. This brings in a whole other set of circumstances for a drummer. I've talked with quite a few drummers, and we all agree that some mental adjustments have to be made to adapt to this method of recording.

As this method became popular, drum parts became overdubs, and that was a new experience for drummers. Producers would sometimes scrutinize every single note of an overdub, and would want complete control over the drum part—especially the fills. Things they would normally have loved when played "live" were now being discussed and questioned. "Oh, I don't know about that fill; what else do you have?" or, "I don't like that at all; could you play something else?" We all had to check our attitudes, take deep breaths, and count to ten a lot when this method came into vogue! And we had to dig deeper to please everyone, and still play with fire and emotion. We had to go with the program if we wanted to continue to work. But adversity can build character and is often a good teacher.

Can passion be taught or learned? Are some of us just lucky to have it? Why do some of us lack it? Maybe we need to interview a few psychologists, sports managers, or movie directors on that subject. It's within everyone to feel passion about something in their lives. It's possible to recall this intense emotion and channel it into your music. Positive emotions can be used to charge your mind and body with energy, and help you overcome the negative forces in your life. A concentrated effort on faith, expectation, and love increases the all-important ingredients of success, which are *enthusiasm* and *self-confidence*.

There's a great story from the World Series that is analogous to our discussion. Kirk Gibson of the L.A. Dodgers had a pulled hamstring and a bad knee. Hearing that he had no chance to play in game one, he quietly iced his knee so he wouldn't feel the pain. He took some practice swings under the stadium, convinced manager Tommy Lasorda he could hit, and hit a home run in the bottom of the ninth to win the game. "There was a lot of visualization, and a lot of talking to myself," said Gibson. "I refused to think about the pain." "Talk about a competitor," Lasorda said. "The guy drives himself to the peak of his ability every game."

All the session greats love to see the tape machine start rolling, despite the situation they might be in. They try their best to do the job they've been called to do with all the emotion and feeling they can muster. They drive themselves to the peak of their ability. This is an important trait for a musician—particularly a studio musician. I'm always striving to have producers and artists say about me what Lasorda said about Gibson—that I give it all I've got, whatever the task, *regardless* of the situation.

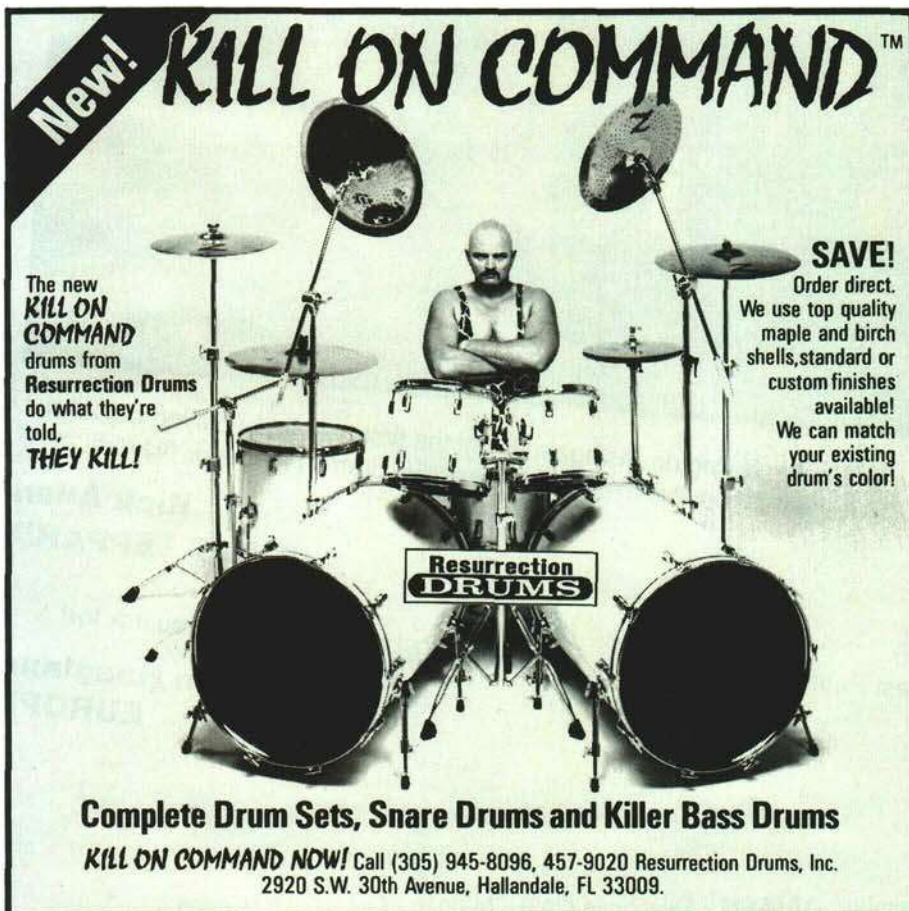

New! **KILL ON COMMAND™**

The new **KILL ON COMMAND** drums from Resurrection Drums do what they're told, **THEY KILL!**

SAVE! Order direct. We use top quality maple and birch shells, standard or custom finishes available! We can match your existing drum's color!

Resurrection DRUMS

Complete Drum Sets, Snare Drums and Killer Bass Drums

KILL ON COMMAND NOW! Call (305) 945-8096, 457-9020 Resurrection Drums, Inc. 2920 S.W. 30th Avenue, Hallandale, FL 33009.

T O T A L M U S I C



GIT

BIT

PIT

VIT

MUSICIANS INSTITUTE
1655 MCCADDEN PLACE BOX 400
HOLLYWOOD, CALIFORNIA 90028
213-462-1384

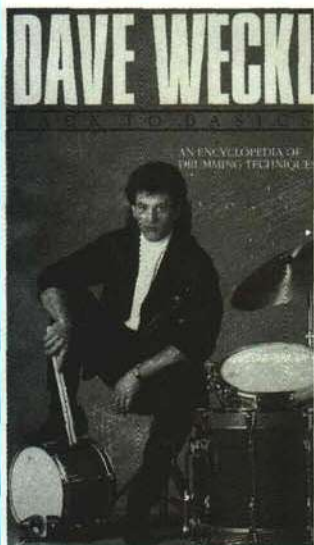

DAVE WECKL
BACK TO BASICS
 DCI Music Video Inc.
 541 Avenue Of The Americas
 New York NY 10011

Time: 72 minutes
Price: \$39.95 (VHS/Beta)

Some drummers are just naturally great players, but have difficulty teaching others what they do. Others are superb teachers who can analyze things and tell you how it's done, but are not generally known as great players. Every so often, someone comes along who makes his or her mark as a great player, and is equally effective as a communicator. Dave Weckl is such an individual. Weckl is as articulate as he is talented, and nowhere is this more evident

than on *Back To Basics*, DCI's most recent offering for drummers.

This video deals with the most basic of drumming concepts, but offers a great deal of sound advice. Elements of both hand and foot technique are dealt with in two thorough segments. Beginning with stick grips and the elusive finger-bounce technique, Dave builds to a meticulous demonstration of some key rudiments on snare drum, and then how those rudiments could be applied to the drumset. There's also a discussion of coordinated independence as it applies to rock and jazz, and some very revealing thoughts on setting up the drumset to achieve maximum results. Another nice feature is Dave's step-by-step approach to one of the most basic of all subjects—the proper tuning of a drum.

We also get to enjoy plenty of Weckl's tasty solo excursions in addition to the words of advice, along with a fine example of brush technique to the sounds of Chick Corea's "Again And Again." One other highlight is Dave's inspiring performance of "Spur Of The Moment," from his *Contemporary Drummer + One* package, also heard on the MD October '87 *Sound Supplement*.

This is a highly professional production, superbly edited, with camera work sensitive to what a drummer wants and needs to see—commendable trademarks of nearly all recent DCI productions. Although this tape is great for beginners/intermediates, you shouldn't feel this is beneath you if you're beyond that. *Back To Basics*, presented by one of today's most talented and astute players, deserves the attention of any serious student of the instrument.

—Mark Hurley

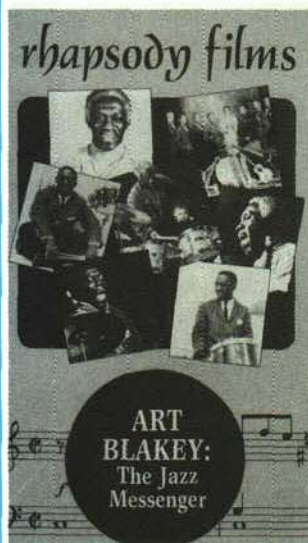

ART BLAKEY:
THE JAZZ MESSENGER
 Rhapsody Films, Inc.
 P.O. Box 179
 New York NY 10014

Time: 78 minutes
Price: \$39.95 (VHS/Beta)

"Kenny Clarke was the Godfather; Max was the painter; but Art was the volcano." Set behind snippets of films of these drumming legends, this quote by Dizzy Gillespie is but a tiny sampling of some of the fantastic material found on *Art Blakey: The Jazz Messenger*. Besides featuring live Blakey performances (including a 1947 concert with Billy Eckstine's band and 1986 gigs in London with Courtney Pine's Jazz Warriors and young British dance groups IDJ and the

Jazz Defektors), we are allowed to drop in on Blakey during band meetings, rehearsals, and at Mikell's jazz club in New York City, where, after word got out that several Messengers were leaving the band, a host of young players descended upon the club and took their best shots at impressing the master and hopefully winning an "apprenticeship."

This might not be an "instructional video" in the usual sense of the term, but this collection of live performances and conversations between jazz greats (the reminiscences of Dizzy and Walter Davis, Jr. are classic) lets us in on some information that "1 e & a 2 e & a..." simply can't touch. "Jazz" is infinitely more than "just the notes," as Art intimates early on, and a retrospective of Blakey's career is as good a place as any to learn what a musically and culturally vital style jazz was and still is. There is certainly something to be said for experience being the best teacher, and this tape makes that very clear.

The Jazz Messengers possess more of an appropriate name than most bands; it's almost been Blakey's mission over the years to keep the jazz "fire" burning and bringing the message to the people, and his work with young black Brits who have "rediscovered" the form (significantly through Blakey's music) testifies that this is as valid a form of communication for some people today as it ever was. The list of musicians who graduated from the Blakey school is an obvious hint at his enormously important stamp on jazz history, yet watching modern dancers inspired by Blakey tunes like "Night In Tunisia" (which still sounds pretty damn "modern" today) is perhaps the best proof of the music's value and spirit. Nicely photographed, cleverly edited, and always entertaining, *Art Blakey: The Jazz Messenger* captures that spirit accurately and artistically, and portrays an artist as relevant today as he was 40 years ago.

—Adam Budofsky



AIRTO & FLORA PURIM
THE LATIN JAZZ ALL-STARS
 View Video

34 East 23rd Street
New York NY 10010
Time: 60 minutes

Price: \$29.95 (VHS/Beta)

While overall this is an enjoyable program, the subtitle indicates its primary problem. Rather than being Airtto and Flora with their own band playing Brazilian-style music, this concert, recorded at the 1985 Queen Mary Jazz Festival, merges their basic band with a group of Cuban/Puerto Rican-style percussionists and horn players. Putting the two traditions together under the "Latin" umbrella produces music that is very strong rhythmically, but it often suffers

from a lack of strong focus or identity.

The problem is most obvious on the first tune, which features a drumset player, a conga player, and a timbale player, in addition to Airtto, who plays surdo. There is really no room in such a setting for Airtto to display his unique sense of color and rhythm, and he stays very much in the background.

Happily, things get better from that point. Airtto steps forward to play a short berimbau solo, which leads into a performance of "Capoeira," the Brazilian martial-arts dance, complete with dancers. Flora Purim is the focal point of the next few tunes, with Airtto moving between his percussion table and drumset. Again, because of all the other percussionists on the stage, Airtto doesn't have a lot of space.

The highlight of the tape is the final song, "Light As A Feather," which dates back to Airtto and Flora's membership in Chick Corea's

WUHAN

*TRUST THESE
WORLD PERCUSSION
USERS*

Jeff Porcaro - Toto
Brian Kilgore
Micky Hart - Greatful Dead
Chico Batera - Sergio Mendez
Bobby Figueroa - Beachboys
Prarie Prince
All Reggae
Burleigh Drummond
Jimmy Fox
Steve Forman - Studio
Stu Nevitt - Shadowfax
Mike Fisher - Studio
Jim Loveless
Gary McLaughlin - Buddy Miles
Ed Mann - Frank Zappa
Airto - Studio
Ron Powell
Michael Spiro - Studio
Jeff Hamilton
Chad Rager
Trilock Gertu - Oregon

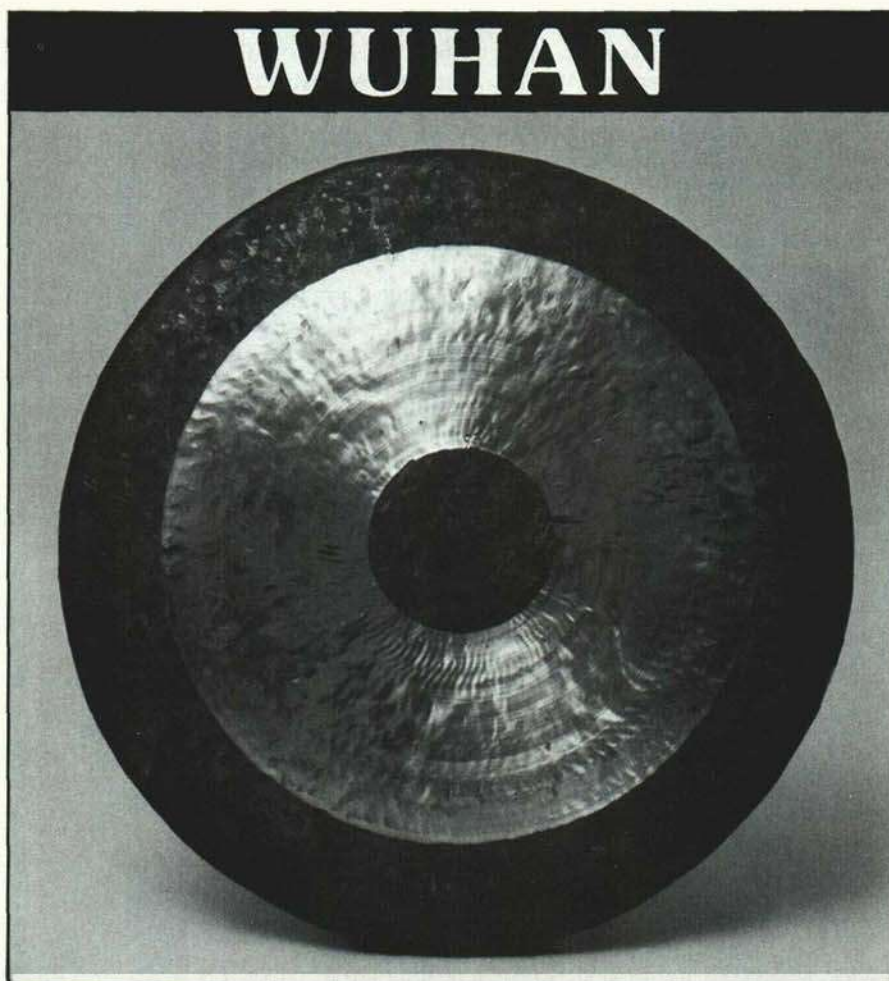

Driving Ride Cymbal

Funky Crash

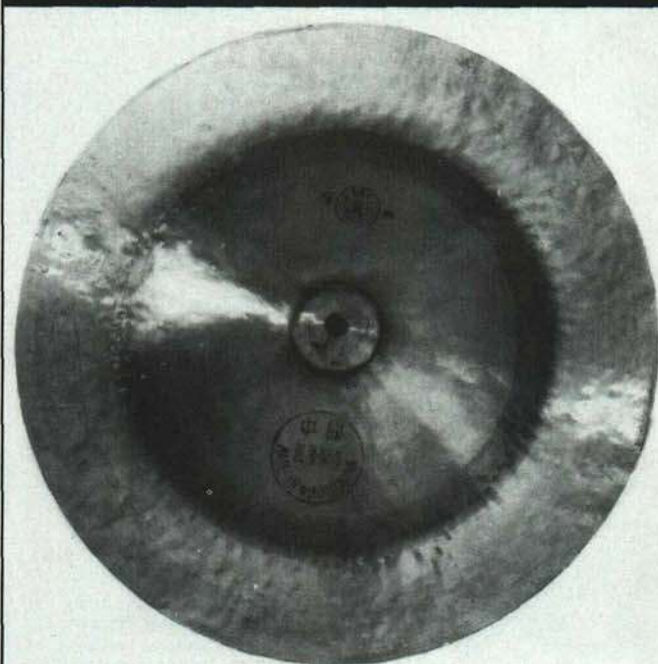

WORLD PERCUSSION

D Paul
R eal
sales

1507 MISSION STREET, SO. PASADENA, CA 91030
(818) 441-2484 • FAX (818) 441-6686

Insist on the best—INSIST ON WUHAN

original Return To Forever group. This tune features only Airto and Flora's band, and it gives Airto plenty of room for his very individual drumset style.

If you are looking for the definitive Airto video, it hasn't been made yet. But this is an enjoyable performance, and does offer a look at a couple of Airto's many sides.

—Rick Mattingly

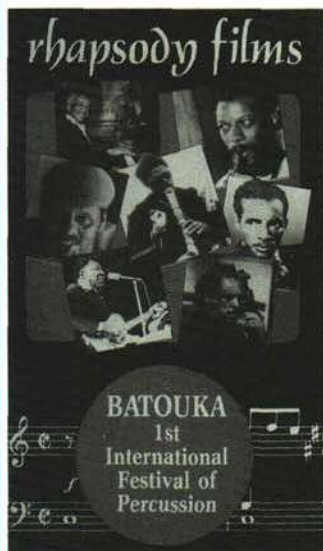

BATOUKA
1st INTERNATIONAL FESTIVAL OF PERCUSSION
 Rhapsody Films, Inc.
 P.O. Box 179
 New York NY 10014
Time: 52 minutes
Price: \$39.95 (VHS/Beta)

If you're into percussion from various parts of the planet, *Batouka*, 1st International Festival Of Percussion might be of limited value to you. The festival took place in April of 1986 on Guadeloupe, in the French West Indies, "the historical crossroads where Africa, Europe, and the two Americas meet," according to the notes on the back of the video jacket. The film features lots of live performances and interviews with many

of the musicians; only problem is, all the interviews were conducted in French. One would imagine some interesting information is being discussed; I couldn't tell you, though, because there

aren't any subtitles, and there is no narration.

Some of the performances included on *Batouka* are by Les Tambourinaires du Burundi, Djoliba Percussions, from Mali, Martin St. Pierre, from Argentina, Carnot "Agouba," from Guadeloupe, and Nana Vasconcelos, from Brazil, who performs a berimbau solo. Besides providing a good sampling of musics from several cultures, we get up-close views of many different percussion instruments, the sounds they produce, and the situations they may be used in.

The term "world music" is probably as useless a phrase as can be (what does that mean, anyway?), yet, despite any cynicism resulting from third world music being plundered by rampant New Agers, the sharing of music and cultures of other countries is ultimately a good thing, because it makes everyone's music more interesting. If you're looking to make your music more interesting, or maybe just want to check out what has been traditionally done for ages on the percussive instruments of other countries, *Batouka* might prove a swell place to start. Certainly if you have had your appetite whet by the music of Peter Gabriel, Sting, or Talking Heads, it might be a good idea to see what convinced these musicians to look afar for inspiration. One would only hope for subtitles next time around.

—Adam Budofsky

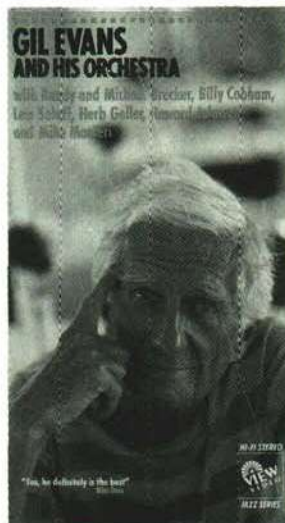

GIL EVANS AND HIS ORCHESTRA
View Video
 34 East 23rd Street
 New York NY 10010

Time: 57 minutes
Price: \$39.95 (VHS/Beta)

Over the years, Gil Evans brought together many different musicians to play his innovative compositions and arrangements. He wanted the individual musician to be able to bring his or her own sound and interpretation to his music. This video, which was taped in Switzerland in 1984 in front of a large audience, brought together some very heavy-weight players, including the Brecker Brothers, Mike Mainieri, Lew Soloff, Howard Johnson, Tim Lander, and others. Of main interest to MD readers is that Billy Cobham is in the driver's seat for this big band.

This all-star band's performance is very loose, which is surprising, and things only really begin to happen during the solo sections of the tunes, when these guys can stretch out. For the most part, Cobham plays a very supportive role, laying back and adding to the music in a subtle way. Along with his massive drumkit, Billy brought a multi-percussion rack, set up behind him, which he plays quite a bit. When it does come time for Cobham to lay it down on the drums, like on "Here Comes De Honey Man," he plays with all of the intensity and chops that he is famous for (even standing up and playing at times!).

Both the sound and the camera work on this tape are excellent, and Cobham is featured in a majority of the shots. This video reveals a few different sides to Billy's playing, both visually and musically. However, because of the overall performance of the band, which at times doesn't live up to the reputation of these gentlemen, I would only recommend it to die-hard Cobham fans.

—Frederick Bay

NEW

INTRODUCING THE BEVEL
 DRUM PRACTICE PADS

Ken® STUDENT BEVEL
 MODEL NO. 2000

Now with the new beveled edges. The responsive white pad is elevated making practice easier and putting you right on target! Beautifully finished in "Hi-Gloss" Red Enamel, the 2000 is ideal for student or teacher at half the cost of most pads.



Ken® PROFESSIONAL BEVEL
 MODEL NO. 2001

Designed for the more advanced student, the 2001 is larger and comes equipped with four plastic feet to prevent walking and to maintain a quiet noiseless action. The PRO Model has many of the features of higher priced pads but sells for much less.

MADE IN THE US

JEMM CO. • 3300 Walnut Street • Denver, CO 80205 • 1-303-296-1660

HOW I MIC DRUMS

DAVID MORGAN
TOURING HOUSE
SOUND ENGINEER FOR
WHITNEY HOUSTON
AND PAUL SIMON.



"I'm using Shure's SM98 more and more because it helps me get that natural drum sound and the mic adds no 'color' of its own. Its small size doesn't obscure the audience's view of the drummer and means the mic is less likely to get hit by drumsticks.

"I prefer the warm natural sound you get with condensers. That's why I like the rich lows and low-mids I get with the SM98 on tom-toms. Plus it's rugged enough to stand up to road abuse.

"To get the fat sound I want, I position the mic about three fingers distance off the drum head and aim it toward the center to avoid unwanted rim harmonics.

"To minimize leakage from adjacent drums, I use Shure's A98SPM polar modifiers to get the isolation a supercardioid provides. I've found that combination works great overhead on the high hat as well. With the pattern control the modifiers provide, it's like having two mics in one.

"For area miking of percussion instruments, I prefer the SM81 because of its extended flat frequency response. And the SM57 still is my first choice on snare and guitar amps."

If you're looking for answers to your miking problems, start where David Morgan does—with Shure.

Call for a free copy of Shure's full line Microphone/Circuitry Catalog. Call 1-800-257-4873 (In Illinois 1-800-624-8522).

Shot on location, Whitney Houston Concert, Madison Square Garden, New York.

ON TOUR WITH **SHURE**



**TICO TORRES (OF BON JOVI)
DRUMMING ESSENTIALS**
Hot Licks Productions, Inc.
P.O. Box 337
Pound Ridge NY 10567
Time: 60 minutes
Price: \$49.95 (VHS/Beta)

This is an excellent video for beginning to intermediate drumset players primarily interested in rock drumming. Tico's presentation is casual, friendly, and sincere, and his desire to communicate his information is apparent. He doesn't go into great detail on any specific techniques; instead, he gives brief—but worthwhile—tips on a wide variety of subjects. He follows each tip with a short demonstration, visually and aurally rein-

forcing what he has just said. The feeling you get from watching this tape is that Tico has invited you over to his house to have a couple of beers and "talk drums."

After an introductory solo, Tico begins by encouraging the viewer to keep an open mind about all styles of music, and to listen to as much drumming as possible. From there, he goes into stick selection and care, the use of drum gloves for hand protection, mallets and brushes on the kit, and grip choice. He stresses flexibility and adaptability on the different drumsets a drummer might encounter in studio situations or on jam sessions, then goes into a brief explanation of how he tunes a drumkit.

Following a few maintenance tips, Tico demonstrates snare drum tuning. Throughout his conversation, he reiterates the value of hitting the drums *hard*, reminding the viewer that a drumhead can take 10,000 pounds per square inch of pressure. He points out the importance of hitting the drums at a consistent level, with definition and precision, in order to give studio or concert engineers what they need. Again, this is pretty much from a hard-rock perspective, but that's Tico's gig, after all. The discussion of tuning leads to bass drum muffling techniques and a quick tip on isolating the snare drum sound from other mic's by the use of a towel taped around the shell.

The subject of back pain comes up, and Tico (along with his dog, Cimba) demonstrates several exercises to alleviate this problem. He then goes into cymbal techniques, demonstrating how he uses the edges, tops, and bells of cymbals. He also discusses how accents in ride patterns can help to create different feels.

A section on what Tico calls "cross-clicking" (using the stick backwards on both drum and rim) follows. Tico demonstrates a quasi-Latin pattern in this section, and a musical example is shown on the screen. Unfortunately, the musical example (which is also provided on paper along with the videocassette) does not match what Tico is playing exactly, which may lead to some confusion. But the technique itself is quite musical and interesting.

Tico follows with comments about how important it is to hold a groove, and how "simplicity is genius sometimes." He goes into the use of buzz rolls, and then closes with yet another encouragement to drummers to gain input from as many sources as possible. Following a closing solo, a brief discography is flashed on the screen, giving the titles to albums by drummers Tico has referred to during his presentation.

All in all, this is a useful video for drummers who may not have a great deal of experience yet on the professional scene. It isn't full of earth-shattering revelations, nor will it make anyone a playing monster. But it does contain a good deal of information that is easy to watch and assimilate.

Rick Van Horn

KEEZER ON DRUM SET
University of Wisconsin
Dept. of Continuing Ed. in the Arts
Room 726 Lowell Hall
610 Langdon St.
Madison WI 53703
Time: 112 mins.

Price: \$89.50 (VHS only)

"Who is Ron Keezer?" you may ask. Well, he teaches percussion at the University of Wisconsin, and *Keezer On Drum Set* is his "video lecture," more or less, on the very basics of drumset. The video is aimed at beginning drummers or those without much ability in the area of styles, and also toward teachers who aren't specialists on drumset.

As far as being one neat little package on learning all the basics about drumset, *Keezer* is adequate. The tape is almost two hours long, is accompanied by a table of contents of sorts that allows you to easily find any particular point on the tape fairly easily, features musical notation examples for clarity, and covers a couple of dozen different styles, along with the basics of how to set up the drums, how to tune the drums, drumset fills, solos, and interpreting drumset music. Keezer slowly explains each style and subject ever so carefully, enunciating each syllable so that nobody could possibly be confused as to what he means at any given time.

Though *Keezer* certainly covers the gamut of styles, etc., the entire video has the air of a two-hour college lecture class. True, this shouldn't take away from the content of the tape, but younger players, whom one would imagine this tape is aimed at, can become fidgety pretty quickly, and the not-quite-MTV-quality quick edits during Keezer's demonstration of rock beats probably won't be enough to retain concentration, either. One other factor that may make this tape more suitable for teachers than for our little future Terry Bozzios is the price tag: \$89.50. It's probably easier to get a check for that amount out of your average school board than it is from mommy and daddy. Yet despite the rather droll quality of the tape and its high price, *Keezer On Drum Set* could very well be just what a lower level music teacher might need to help build a curriculum on basic drumset for beginners.

—Adam Budofsky

STICK TWIRLING
Stage One Video
Box 806171
Chicago IL 60680-4123
Time: 20 minutes
Price: \$20.00 (VHS only)

This is a brief video totally dedicated to the stick-juggling theatrics prevalent in arena-rock playing. A relatively amateurish production (that appears to be a self-produced effort), the video features drummer Tim Tully demonstrating a wide variety of stick twirls, spins, tosses, catches, and other tricks. He also offers some interesting methods of taping sticks to make them easier to twirl. Tim seems a bit uncomfortable in front of the camera at first, but warms up to his subject as he goes along.

A positive feature of Tim's presentation is that he mentions several times that stick "tricks" should not be allowed to get in the way of a drummer's playing. Another point he makes is that drummers who employ stick tricks will often lose sticks in the process—as he does himself several times—and should just "laugh it off and stay cool." For those interested in developing the showmanship that helps arena-rock drummers "wow" their audiences, this is the tape to check out.

—Rick Van Horn



BY MUSICIANS...

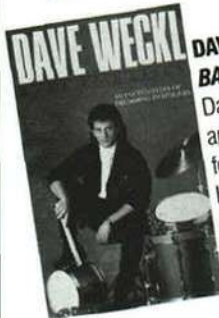

DAVE WECKL
BACK TO BASICS—In this inspiring video, Dave outlines his philosophy and technical approach to the drums, covering stick control, foot technique, brushes, and independence. He performs with several tracks from *Contemporary Drummer + One* and plays some explosive solos. An encyclopedia of drumming techniques. 72 minutes.

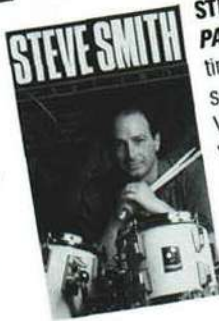

STEVE SMITH
PART ONE—Steve describes and demonstrates methods for developing time and meter and his basic approach to rock and jazz. Includes some incredible solos and several performances with Steve's group Vital Information. *Best Music Instruction Video* of 1987 (American Video Awards). Booklet included. 60 minutes.

PART TWO—is an exciting follow-up with invaluable tips on double bass drumming, developing creativity, soloing, and creating a drum part. Includes rare in-concert footage of *Steps Ahead*, plus great performances by Vital Information. Booklet included. 54 minutes.

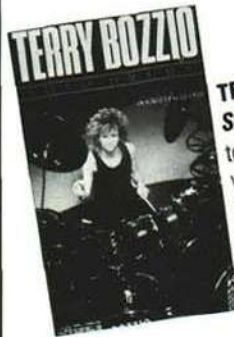

TERRY BOZZIO
SOLO DRUMS—Terry presents his overall approach to the drum set, starting with an incredible solo which he breaks down section by section, explaining each technique used. He also covers double bass drumming, hand technique, 4-way independence, and offers a study of his drum part for *U.S. Drag*. Booklet included. 55 minutes.



ROD MORGENSTEIN
PUTTING IT ALL TOGETHER—Rod discusses how to develop versatility, how to create a drum part, techniques for playing in odd time signatures, and his approach to ghost strokes and double bass drumming. On-screen graphics included. 60 minutes.

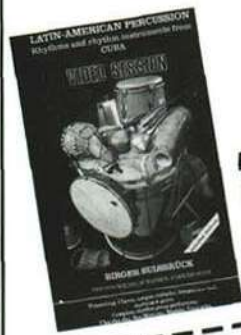

LATIN AMERICAN PERCUSSION Designed for both beginner and experienced players, features expert percussionist Birger Sulsbruck. He offers the basic techniques for playing congas, bongos, timbales, and shakers and demonstrates many Afro-Cuban rhythms. Examples of ensemble-playing are featured. Booklet included. 45 minutes.

FOR MUSICIANS.



- VIDEOS** **DAVE WECKL, Back to Basics** \$39.95 **TERRY BOZZIO, Solo Drums** w/booklet \$39.95 **STEVE SMITH, Part One** w/booklet \$39.95 **STEVE SMITH, Part Two** w/booklet \$39.95 **STEVE GADD, Up Close** (60 min.) \$49.95 **ROD MORGENSTEIN, Putting It All Together** \$39.95 **STEVE GADD, In Session** (90 min.) \$59.95 **KENNY ARONOFF Laying It Down** w/booklet (60 min.) \$39.95 **Latin Percussion** w/booklet \$39.95 **STEVE GADD, In Session** (90 min.) \$59.95 **Snare Drum Rudiments** w/pamphlet (30 min.) \$29.95 **Double Bass Drumming** (60 min.) \$39.95
- AUDIOS** **DAVE WECKL Contemporary Drummer + One** Cassette, 40-page book, charts (in plastic storage case) \$32.95 **ROD MORGENSTEIN Grooving in Styles/Filling in the Holes** \$24.95 **Odd Times** \$24.95 **Double Bass Drumming** \$24.95 **All Three Morgenstein Packages** \$69.95

Make check payable to: **DCI MUSIC VIDEO INC.** 541 Avenue of the Americas, New York, NY 10011

Add \$4.00 shipping—\$7.00 outside the U.S. (N.Y.S. residents add 8 1/4% sales tax) Allow 2-4 weeks for delivery. PAL available—add \$6.00 per tape.

Name _____ Address _____ City _____ State _____ Zip _____ Phone _____

Signature _____ **BETA** _____ **VHS** _____

Mastercard/Visa (circle one) Card # _____

To order by phone: 1-800-342-4500 Mon.—Sat. 10AM—9PM EST N.Y. State (212) 691-1884

IN EUROPE: Music Mail Ltd., 43 South Molton St., London W1Y 1HB England Tel: 01-857-6309

IN CANADA: Checks must be drawn on US bank or International Postal Money Order.

COBHAM AND 64 DRUMMERS SET RECORD

Late last year 65 drummers played themselves into the *Guinness Book of World Records*. For the 65th birthday of Serlui, the Dutch distributor of Tama and Zildjian products, Mike van der Logt of Serlui organized a mass drumming event. Erk Willemsen (of the Dutch drumming magazine *Slagwerkkrant*) composed a piece for four groups of 16 drummers and a soloist, who was Billy Cobham.

The goal was to set a previously non-existent record by having the group play synchronously for ten minutes. The composition, which was simple yet full of surprises, was rehearsed in half an hour by the enthusiastic members of the group (who had to unpack and set up the Tama *Rockstar* kits provided for the event prior to the show). Trying to imagine what it sounds like when 65 drummers lay down a backbeat together is almost impossible. I can assure you that it's quite impressive.

When asked for his impressions after the performance, Billy Cobham said, "It



was fun. The fact that we were able to keep some type of cohesion promotes the concept of being able to play together in any situation, as long as everybody is listening. If everybody is concentrating there are a lot of things you can do."

—Hugo Pinksterboer

MD TRIVIA WINNER

The lucky recipient of Rod Morgenstein's prototype Premier APK drumset is **John Mauro**, of Highland Park, New Jersey. John's card was drawn from those with the correct answer to the three questions posed in *MD's* December '88 issue:

THE NATIONS ELECTRONIC DRUM CENTER



Photo by Dane

NATION'S LARGEST SELECTION
WE BEAT DEALS NATIONWIDE!
 CALL US AND WE'LL PROVE IT TO YOU.
 CALL FOR EXPERT ADVICE
ASK FOR OUR TOLL FREE ORDER NUMBER
1-713-781-DRUM
 5626 Southwest Frwy, Houston, TX 77057

finally...

STEVE SMITH- Part two

- Developing Creativity
- Double Bass Drumming
- Soloing
- Odd Groupings
- Great Performances with Vital Information
- Rare In-Concert Footage of Steps Ahead

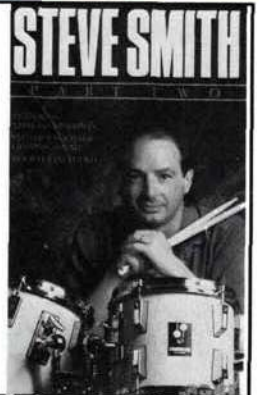

Please send me: **STEVE SMITH** Part Two Part One \$39.95 each

Name _____ VHS BETA

Address _____

City _____ State _____ Zip _____

Make check payable to: **DCI Music Video**
 541 Ave. of the Americas
 New York NY 10011



Add \$4.00 shipping per order—\$7.00 outside U.S. (N.Y. State residents add 8 1/4% sales tax). Allow 2-4 weeks for delivery. PAL available—add \$6.00 per tape.

MasterCard/Visa Card # _____

Exp. Date _____ Signature _____ MD 589

To order by phone: **1-800-342-4500** Mon.—Sat. 10 a.m.—9 p.m. EST;
 in New York State, (212) 691-1884

IN EUROPE: Music Mail Ltd., 43 South Molton St, London W1Y 1HB, England; Tel. 01-857-6309
Canadian Orders: Must be paid with International Money Order or check drawn on a U.S. bank.

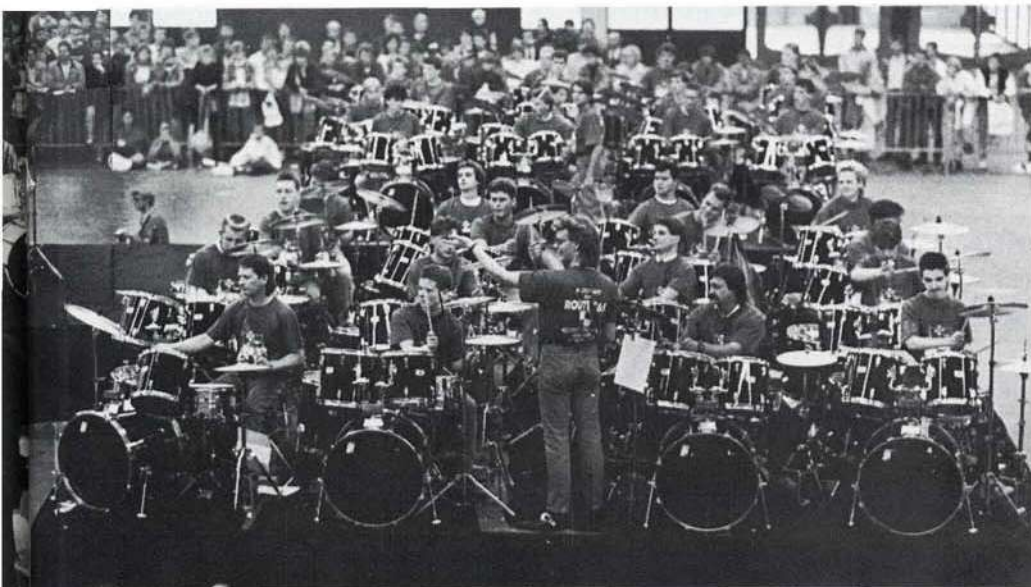

Photo by Joost Leijen

1. Rod met the other members of the Dregs at what university? (University of Miami.)
 2. What category in the MD Poll did Rod win this year? (Progressive Rock Drummer.)
 3. Where are Premier drums manufactured? (Leicester, England.)
- Congratulations to John from Rod Morgenstein, Premier Drums, and *Modern Drummer*

SELMER BUYOUT INCLUDES LUDWIG/MUSSER

The Selmer Company, parent company of Ludwig drums and Musser mallet keyboard instruments, has undergone a management-led buyout from North American

Phillips. The buyout was sponsored by an affiliate of Integrated Resources Acquisition, Inc., of New York.

H. William Peterson, president of Selmer, said, "The management of The Selmer Company is extremely pleased with this transaction, for it enables Selmer to maintain its identity as an American manufacturer of a complete line of band and orchestral instruments and accessories." The possibility of Selmer being put on the stock market as a publicly traded company sometime in the future was also suggested by Peterson.

INT'L MARIMBA COMPETITION

The "Jacques Delecluse International Percussion Competition," organized by the Atelier Regional de Musique Nord-Pas de Calais and the Concerts Company of St. Omer, with the assistance of the General Council of the district of Pas de Calais, will take place from July 17 through 21,

ALL ABOARD.

DYNACORD'S NEW ADD-two Advanced Digital Drums

ADVANCED 16 BIT DIGITAL DRUMS & SAMPLER

UNPRECEDENTED SOUND QUALITY. State-of-the-art "Full-Spectrum" circuitry featuring 16 voice sound generation, dynamic voice allocation and a "Double Over-Sampled" composite output rate of 20 bits at 88.2 kHz on each of 8 polyphonic outputs.

DISK DATA STORAGE & 16-BIT SAMPLING. 16-bit user sampling (up to 95 seconds of sound at 44.1 kHz) and High Density disk storage of sound and program information on the internal floppy drive. Also factory equipped SCSI port for hard disk interface.

PROGRAMMABLE TUNING, PROCESSING & MIXING. Fully programmable drum tuning parameters (pitch, duration, volume, panning, etc.), onboard chorus, echo, flanging and sound fusion effects as well as digital mixing and external effects sends.

SENSITIVE, INCREDIBLY ACCURATE TRACKING. A thorough implementation of MIDI and adjustable signal sensitivity curves provide flexible, yet precise tracking from virtually any source (pads, pedals, triggers, mikes or tape).

PLAYER DEFINED PERFORMANCE PARAMETERS. Sophisticated modulation matrix allows a wide range of programmable functions to be assigned to any of several performance controllers; for example, dynamic level or stroke rate can be programmed to control sample cross switching and cross fading.

DYNACORD ARTISTS: JEFF PORCARO, TOMMY LEE, JONATHAN MOFFETT, CHESTER THOMPSON.

DYNACORD Distributed in the U.S. by: DW/DYNACORD 2697 Lavery Court, Unit 16, Newbury Park, CA 91320, 805-499-6863

1989. The competition is open to all instrumentalists of all nationalities, still under the age of 35 as of July 1, 1989. The 1989 event will be exclusively dedicated to marimba.

Prizes will range from approximately \$800 for third place to \$4,800 for first, along with contracts for concerts and other awards. Master classes by Keiko Abe and Leigh Howard Stevens will take place during the competition, with Grand Finale concerts by both artists (and the contest winners) also scheduled. For information as to repertoire, prizes, jury members, registration, scheduling, housing, and other details, contact Mr. Pierre Frackowiak, Atelier Regional de Musique, 2, Parvis de l'Eglise St Edouard, 62300 Lens, France, (telephone: 21.78.12.28).

DCI CHAMPIONSHIPS MOVED

The 1989 DCI World Championships that were to be held in Montreal, Canada, will now be held in Kansas City, Missouri, due to stadium scheduling problems beyond DCI's control. Present holders of tickets for the Montreal show will be notified in writing during the coming weeks.

The Kansas City Chiefs, operators of Arrowhead Stadium, had an exhibition

football game with the New York Giants scheduled during the week of August 14-19, when the DCI championships are to take place. However, because of the positive reactions to last year's experience and the willingness to accommodate DCI, they re-scheduled their game to Sunday, and offered to add their own promotional efforts to the event.

PATENT FOR EVANS CAD/CAM HOOP DESIGN



Evans Products, Inc., manufacturers of Evans Drumheads, has been issued a U.S. Patent granting them exclusive rights for the use of their CAD/CAM metal hoop drumhead design. Developed in 1987, Evans' computer-assisted design and manufacture of CAD/CAM heads has been credited with bringing an improved level of consistency and quality control to synthetic drumheads by overcoming problems inherent in previous designs and manufacturing processes.

The patented CAD/CAM hoop design includes several unique features, such as a bevelled inside edge, flanged outside edge, fiber-reinforced resin, and invisible internal clip—all acting to increase the strength, uniformity, and performance of the overall drumhead. According to Bob Beals, president of Evans Products, "The drumhead market has been quick to react to the advantages of CAD/CAM heads with replacement head sales skyrocketing and many progressive drum manufacturers considering the use of Evans heads as original equipment on new drums.

"We're very pleased with the situation," continued Beals. "By allowing 18 individual claims on the CAD/CAM hoop design, the U.S. Patent office has confirmed the uniqueness of CAD/CAM drumheads, and their advance in the state of the art."

FOOTES

17, GOLDEN SQUARE, LONDON
W1R 3AG, ENGLAND
TEL: 01-734 1822

PREMIER PERCUSSION

U.K. MAIN AGENT

STOCKISTS OF ALL OTHER LEADING BRANDS OF DRUMS AND PERCUSSION

SPECIALISTS IN EXPORT

WE CAN MAIL ORDER ANYTHING
PHONE OR WRITE FOR YOUR FREE CATALOGUES

EST. 65 YEARS

SAY YES TO DRUMS

with a subscription to **Modern Drummer**



Call Toll Free

1-800-435-0715

SABIAN RECEIVES CANADA EXPORT AWARD

Sabian, Ltd., was recently honored with the 1988 Canada Export Award. Presented by The Right Honorable Joe Clark, Canada's Secretary of State for External Affairs, the award is made each year by the Department of External Affairs to Canadian firms that are judged to be "outstanding achievers" in international trade. It was presented to Sabian in recognition of its success in marketing its cymbals around the world, including major markets in the U.S., Japan, West Germany, and the United Kingdom.

As Canada Export Award winners, Sabian now has the right to use the Award logo on its stationery and promotional material for the next three years. Past winners report that receiving the award, along with the resulting publicity, has helped raise their companies' profiles in Canada and improved their foreign sales.

Sabian credits its employees for much of the company's success in "exporting excellence." Through their efforts, exports rose by 50% in 1987, accounting for 81% of total sales. In 1988, despite intense competition, the company has continued

to increase its share of the world market for cymbals.

YAMAHA'S CONSUMER FINANCE PROGRAM

Yamaha Corporation of America (YCA) announced recently the establishment of Yamaha Music Finance, Inc., to finance authorized Yamaha dealers' sales to consumers. Programs to be offered by the new company include expanded installment loans, seven- to ten-year financing on large purchases, personalized and dealer-specific credit cards for consumers who make small purchases with a dealer, and lease financing up to five years. While financing will be available for all products sold by participating Yamaha dealers, major emphasis will be on the promotion and sale of Yamaha products. Richard O'Donnel, senior vice president of YCA and president of the new corporation, said, "This will give our dealers an additional finance option that will be available in both good and difficult times."

Headquarters for the wholly-owned subsidiary of YCA will be in Buena Park, California. Jack Miller, currently manager of the YCA Credit Division, will also be in

charge of operations and responsible for the day-to-day functions of the finance company. "We'll be open for business April 1, 1989," Miller said.

The company plans its start-up across the country, beginning with California, Oregon, Washington, Idaho, Nevada, Arizona, Montana, Michigan, Minnesota, North and South Dakota, Nebraska, Kansas, Illinois, Indiana, Iowa, Wisconsin, Missouri, Florida, Georgia, and South Carolina. The complete roll-out is expected to take about six months.

ENDORSER NEWS

Newly signed Drum Workshop artists include **Jason Bonham, John Guerin, Joey Heredia, Michael Joachim, Denny Fongheiser, and Carla Azar...** Dynacord has added **Gregory Grainger** to its roster....Swiss drummer/percussionist **Peter Giger** is now a Pro-Mark artist....**Chester Thompson, Jack DeJohnette, and Steven Adler** are Sabian's newest players....LP has announced **Dave Weckl and Rikki Rockett** as endorsers....Compo drumheads are being played by **Carl Allen, Pablo Batista, Tommy Campbell, Fran Christina, Frank Colon, Johnny Dee, and J.T. Lewis.**



Manny's Music, Long Island Drum Center and Scabeba Ent. Present:

The First Annual BUDDY RICH MEMORIAL SCHOLARSHIP CONCERT

Featuring
The Buddy Rich Big Band
Cathy Rich
Steve Gadd (Zildjian)
Vinnie Colaiuta (Yamaha)
Dave Weckl (Zildjian)
Louie Bellson (Remo)
Gregg Bissonette (Pearl)
Joe Morello (Ludwig)
Dom Famularo (Tama)
Jim Chapin (D.W.)
Al Miller (Premier)

Monday night, 7:30 p.m., April 3rd at the Westbury Music Fair, Theater In The Round, Westbury, L.I., NY

Tickets: \$15, \$20, \$25, plus 1 can of food for L.I. CARES.

Call or write for tickets to:

Long Island Drum Center
2489 Charles Ct.
N. Bellmore, NY 11710
(516) 781-0777

or

Manny's Music
156 W. 48th St.
New York, NY 10026
(212) 819-0576

AVAILABLE FROM GARY CHAFFEE

NEW!! PATTERN VOL IV (Technique)

A comprehensive system of hand and foot coordination. Contains endurance exercises, finger control, multiple-note groupings, and much more.

Also Available:

Patterns Vol. I (Rhythm and Meter)
Patterns Vol. II (Stickings)
Patterns Vol. III (Time Functioning)
Video Patterns-Stickings (60 min. VHS)

Here's what today's top players have to say:

"Gary's books get you in tune with all the possibilities available to you as a drummer."

STEVE SMITH

"Gary's materials are really in touch with the directions that drumming is going in."

DAVID GARIBALDI

"Gary has a really cool method of teaching independence and polyrhythms. He shows you how it's broken down, and what it's based on."

VINNIE COLAIUTA

PATTERNS VOL. I, II, III, IV \$12 per book; \$48 for set
VIDEO PATTERNS-STICKINGS \$57 per copy

All orders add \$2 shipping; outside USA, add \$5
Send check or money order to:

GC MUSIC

16 White Oak Rd., W. Roxbury, MA 02132

NEW DRUM WORKSHOP PRODUCTS

New DW products debuted at the NAMM Winter Market include a new series of American-made, economically-priced single and double bass drum pedals, new cymbal and snare drum stands, and the *Metropad*, a drum practice pad with a built-in metronome.

The *5000N* single bass drum pedal and *5002N* double pedal feature DW's original nylon strap-drive system and American-made, die-cast aluminum parts. Both can easily be upgraded to include DW's patented "chain & sprocket" drive if desired.

The 9700 cymbal stand comes with stainless-steel upper sections, a universal fitting for use as a straight or a boom stand, and a patent-pending tilter assembly. The 9500 and 950? snare drum stands have been designed to provide a method for greater position, angle, and height adjustments not previously available.

The *Metropad* combines a gum rubber practice pad with a built-in electric metronome and a pair of headphones. This offers a drummer a silent playing surface and a timekeeping device in one convenient, portable unit. For more information on any DW product, contact Drum Workshop, 2697 Lavery Court, Unit 16, Newbury Park, California 91320, (805) 499-6863.

GIBRALTAR HARDWARE LINE EXPANDS

Kaman Music Corp., distributor of Gibraltar Hardware and Accessories, has introduced the Gibraltar *Percussion Service Center* product line. The line features over 80 of the most asked-for drum parts and accessories, including drum rack parts and accessories, clamps and mounting systems, *Spanner* system parts and accessories, high-use replacement parts, power hoops, and custom drum parts. All parts are mounted in individual packaging, so the user can select the items needed to custom-build his or her "ultimate" drum

setup. For more information, contact John Roderick, Kaman Music Corporation, P.O. Box 507, Bloomfield, CT 06002.

DRUM VIDEO FROM PROSCENIUM

Proscenium Entertainment, a newcomer to the videocassette marketplace, has announced the release of *Superdrumming*, which presents seven great drummers in a display of talent rarely seen on a single video. The drummers are Louie Bellson, Gerry Brown, Nippy Noya, Ian Paice, Simon Phillips, Cozy Powell, and Pete York—backed by a band led by Brian Auger. The sessions took place in a West German cathedral that offered superb acoustics. *Superdrumming* is a 55-minute stereo video, available in VHS Hi-Fi by direct mail from Proscenium Entertainment, Box 909, Hightstown, New Jersey 08520, or from selected retailers throughout the U.S. and Canada.

SIMMONS INTRODUCES NEW PRODUCTS



Simmons Electronics has unveiled three new products tailored for performing drummers. *Drum Huggers* are compact MIDI trigger pads that attach directly onto a conventional drum, negating the need for additional hardware while in no way interfering with the sound or playability of the instrument. The AD7 (Acoustic Drum Trigger) is designed for triggering MIDI sound sources from acoustic drum tracks on tape or played live. This rack-mount device has eight audio inputs, with parallel outputs to feed mixing desks. Sim-

mons' "Learn" process samples the trigger source and automatically sets gain, threshold, hold offs, and anti-crossstalk circuits to produce a clean, fast MIDI trigger. A whole range of MIDI effects can be stored along with note, channel, and program data in the AD7's 99 chainable patches. These include compression, expansion, repeat, and dynamic switching, layering, and crossfading. Finally, the *SDS2000* is a new self-contained electronic drumkit designed to supersede the *SDS1000*. The new kit is designed to give electronic drummers a wide range of features at a very affordable price. For more information, contact Simmons Electronics USA Inc., 2630 Townsgate Road, Suite H, Westlake Village, California 91361, (805) 494-5007.

ZILDJIAN EXPANDS PRODUCT LINE

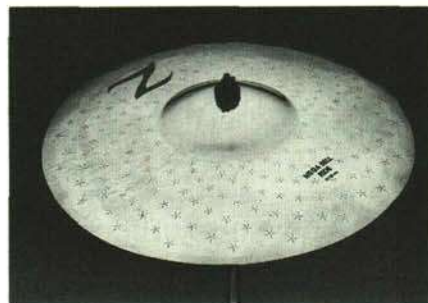

The Avedis Zildjian Company has expanded its product line with the introduction of two new cymbal models: the *K Custom Dry Ride* and the *Z Series Mega Bell Ride*. Also new are the *ZMC-10* cymbal miking system, new bass drum mallets in the *Field Series* drumstick line, and a variety of new accessories in the *Basics* line.

The *K Custom Dry Ride* is a 20" ride designed primarily for jazzier-type ride cymbal figures, and offers a severely ultra-dry stick sound and super-dry overtones. The *Z Series Mega Bell Ride* is available only in a 21" size, and features a bell 8" in diameter. It is designed for very hard-hitting drummers who ride primarily on the bell of their ride cymbals.

The *ZMC-10* miking system gives drummers individual control over each cymbal in their setup. The *ZMC-10* features the

same electret microphones used with the more sophisticated ZMC-1 system. The standard ZMC-W system includes three of these mic's for cymbals and one for hi-hats. The ZMC-10 powered mixer has six channels (similar to the ZMC-1), but is a mono rather than stereo unit. The mixer also features a special hi-hat channel with extra EQ control that controls the clarity of the hi-hat sound by shaping the wave pattern of the microphone. Each channel on the mixer can power two mic's that can be connected via "Y" cords. Extra ZMC mic's are available for larger setups.

Bass drum mallets in four sizes have been added to Zildjian's *Field Series* marching percussion line. The mallets are available in either hard felt or soft puff versions, and are designed to accommodate the 20" to 36" bass drums most commonly used in marching percussion groups. They also feature an adjustable shaft sleeve that affords each player his or her choice of weighing and balancing for maximum control.

In the accessories department, Zildjian is now offering leather drum gloves with vented mesh backs, and the *Drummer's Survival Kit*, which includes spare felt and metal washers, cymbal sleeves, a bass drum beater pad, and snare cord.

PRO-MARK TOMMY ALDRIDGE STICK

Pro-Mark Corporation is now offering the *Tommy Aldridge 2S* model drumstick. The stick is available in Japanese oak or Texas hickory in wood tip only. It is 5/8" (16mm) in diameter and 17" (433mm) long. Each stick is silkscreened with Tommy's signature. Pro-Mark Artist Relations Manager Pat Brown commented, "Tommy Aldridge has contributed enormously to modern rock drumming and has influenced countless musicians. We're pleased to add his name to the Pro-Mark 2S model he's depended on for so many years." For further information, contact Pro-Mark at 10707 Craighhead Drive, Houston, Texas 77025.

YAMAHA OFFERS NEW HARDWARE ITEMS

New from Yamaha are *WHS-850* and *WHS-850S* remote hi-hats, *FP-810*, *FP-820*, and *DFP-850* chain-drive bass drum pedals, and a completely redesigned drum rack system designated *Super Rack*.

The new remote hi-hats utilize *Teflon-coated* cable and a sensitive spring system to ensure smooth operation. A drop clutch mechanism allows the hi-hat to be closed with the tap of a stick; normal operation is restored simply by pressing the pedal. The difference between the two models is

solely the cable length: The *WHS-850* features an 8' 2 1/4" length while the *WHS-850S* features a 3' 3 1/2" length.

Yamaha's *FP-810* and *FP-820* are single pedals featuring a double chain for precise response, maximum power transmission, and durability. They feature a no-sprocket construction designed for silent operation in recording studios and lightweight footboards for unrestricted footwork. The *DFP-850* is a double pedal with a universal joint that attaches with a standard drumkey. Either pedal can be used independently, and the system can be modified for one bass/double pedal, double-bass, or single-bass configurations.

The new *Super Rack System* employs an array of pipes and clamps to facilitate totally customized drum setups. All rack pipes used in the system feature a sound-absorbent foam filling that eliminates sympathetic vibrations. The pipes can be used in conjunction with traditional cymbal stands, or can be supported by the system's own leg components. Memory clamps serve as positioning indexes, making the system fast and easy to use while solidifying the entire setup. For more information on any Yamaha product, contact Yamaha Corporation of America, P.O. Box 6600, Buena Park, California 90622-6600, (714) 522-9011.

PORCARO COMPLETES STAR LICKS VIDEO



Jeff Porcaro, studio ace and Grammy-award winning drummer of Toto, has just completed his first instructional video for Star Licks. Six weeks of pre-production went into the making of this 60-minute video. In it, Jeff describes his approach to straight time, triplet and shuffle feels, and Latin grooves. He also describes and breaks down his most famous groove, from Toto's hit "Rosanna." The video also features Mike Porcaro on bass and David Garfield on keyboards to help provide groove samples and create a live band setting. For more information, contact Noma Video, Inc., 2340 Sawtelle Boulevard, West Los Angeles, California 90064, or call (213)478-8886.

GMS DRUMS INTRODUCED



The GMS Drum Company has introduced its *Grand Master Series* of acoustic drums. The drums feature 45-degree precision-beveled 8-ply all-maple shells, a newly designed all-brass chrome-plated lug with a self-aligning brass swivel lug nut, and minimum shell contact in a high-tension lug. All drums feature high-gloss polyurethane finishes in a variety of solid and me-

Attach your present mailing label here, or write in your old address.
Please include customer code number.

New Address

NAME: _____

ADDRESS: _____

CITY: _____ STATE _____ ZIP _____

MOVING TO A
NEW ADDRESS?

tallic colors, or a natural maple finish. All toms, both rack and floor, come equipped with the RIMS mounting system as standard factory items. Drums are available in standard, power, and custom sizes, and the snare drums feature a unique strainer design. For further information contact the GMS Drum Company, 21 Louis St., Hicksville, New York 11801 (516)931-3023.

INVISIBLE DRUM/ PERCUSSION STANDS



Invisible Products Corporation now offers drum and percussion stands capable of mounting acoustic and electronic drums, cymbals, electronic devices—all in a lightweight, low-visibility package.

The new DP Series stands are available in 41" and 24" widths, and come with a variety of extender boom adaptors for the flexible placement of drums and cymbal arms. Height is adjustable in 1.75" increments from 25" to 49". A variety of accessory items are available for custom-tailoring to a drummer's needs. For further information, contact Invisible Products Corporation, 159 Commercial Street, Lynn, Massachusetts 01905-2909.

HOLDING A DAMAGED COPY?

Occasionally, your issue of **MODERN DRUMMER** can be mutilated in the mail. No need to read a badly damaged copy. We'll send you a new one—Fast & Free!

Just call an MD Service Rep
For Immediate Assistance
1-800-435-0715

(Mon-Fri 8:30 AM-4:30PM CST)
(In Illinois call 1-815-734-6309)

APHEX IMPULSE MODEL 810 MIDI TRIGGER SYSTEM

The Aphex *Impulse Model 810* is a 12-input analog-to-MIDI trigger interface adaptable to

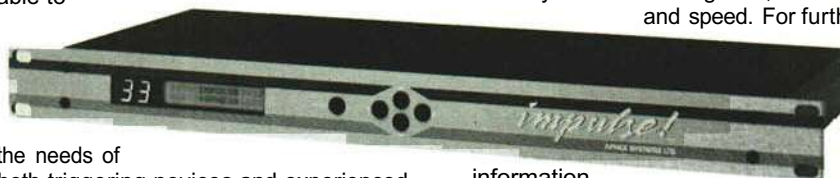

the needs of both triggering novices and experienced professionals. It can be used to control sophisticated rack systems in live applications or to handle complete track replace-

ment sessions. The 12 inputs analyze incoming wave forms and automatically set detection parameters, eliminating the problems of conventional triggering systems. Inputs may be from drumpads, acoustic drums, or taped percussion. A combination of analog and digital circuitry delivers intelligence, accuracy, and speed. For further

information, contact Aphex Systems, Ltd., 13340 Saticoy Street, North Hollywood, California 91605, (818) 765-2212.

AKAI XE8 DRUM EXPANDER

Akai Professional recently released a sampled drum expander offering high-quality drum sounds in what is termed "a



compact, affordable package." The XE8 features 16-bit samples of a variety of drum and percussion sounds in a single-rack-space design. Sixteen different sounds are available in internal ROM, and there are two slots for ROM cards, each of which may contain 16 more sounds. The unit can produce up to eight sounds si-

multaneously, and each sound in a program (32 programs total) can be routed to a Mix output, or to one of eight separate outputs. All of the sounds in a "kit" can be edited, with parameters including Pitch, MIDI Channel, MIDI Note, Range, Sweep,

Decay, Reverse, and more. The XE8 can be triggered from any MIDI controller, and the Akai ME35T trigger-to-MIDI converter can be used by those using electronic pads, miked drums, or any audio triggers. For more information, contact Akai Professional, P.O. Box 2344, Fort Worth, Texas 76113, (817)336-5114.

CAPPELLA OFFERS RESONANT STICKS

Cappella Wood Enterprises is now offering Resonant Drumsticks as part of its Prima by Cappella line. The sticks feature an inset rubber grip for enhanced stick security and comfort. With no tape to wrap, no ridges to straddle, or anything to hamper a drummer's technique, the inset grip—which is flush with the surface of the rest of the stick—allows the fingers and hand to move freely. For more information, contact Cappella Wood Enterprises, P.O. Box 247, Applegarth Road, Hightstown, New Jersey 08520.

NEW MATERIALS FROM ALFRED PUBLISHING

Two new publications are available from Alfred Publishing. *Brazilian Percussion Manual*, by Daniel Sabanovich, is intended for the percussionist who may not be acquainted with Brazilian percussion instruments, rhythms, techniques, and history. The work includes detailed instruction on various instruments, and also contains an extensive study of Brazilian rhythms as applied to the drumset.

Modern Drum Studies, by Simon Sternburg, is a revised edition of a percussion text originally published in 1933 and recognized as a "classic" by many teachers. Recognizing that there are many authoritative works today on Latin percussion and various traps such as temple blocks and timpani, those references have been removed from this revised edition, allowing it to focus on the core materials for reading development of snare and bass drum. For further information, contact Alfred Publishing, 16380 Roscoe Boulevard, P.O. Box 10003, Van Nuys, California 91410-0003.

**REPRINTS of most
MD Feature Articles
and columns ARE
available! Call the
office for a
price quote**



ACOUSTIC TRIGGERING WORKS



LEARN™ ABOUT IT

The **Trixer** from Simmons is all you need to know about triggering from your acoustic drums. Its "Learn" circuit takes all of the hassle out of setting sensitivities – just strike each drum once and the **Trixer** "Learns" your drums, computing the optimum settings to trigger its on-board sounds accurately and fast. From grace notes to rim shots, no MIDI delays, no crosstalk, no double triggering, no drop outs, great tracking and a brilliant dynamic range – guaranteed.

All of the **Trixer**'s digitally sampled sounds are derived from the legendary SDX sound library, and the four kits of bass, snare and four toms can be further

expanded from a selection of sound cards. A six-channel mixer enables the **Trixer**'s sounds to be blended with the mic'd sound of your acoustic kit, and a built-in 16-bit digital reverb offers a choice of 30 programs from small rooms to large halls, gated rooms and reverse echos.

Pad inputs and a stereo headphone socket make the massive sounds of the **Trixer** available for home practice.

Trigger and mix – the **Trixer** – the solution to triggering and acoustic drum reinforcement in one box. Try a **Trixer** at your favorite music store. You might "Learn" something to your advantage.

SIMMONS

DRUM MARKET

If you've got something to sell, instructions to offer, or are looking for a hard-to-find item, advertise in DRUM MARKET and reach over a quarter million drummers worldwide for only \$1.00 per word plus \$4.00 for an address. Minimum charge \$10.00. Underline words to appear in BOLD type and add \$.50 for each bold word. Deadlines for ads: the 20th of the month two months preceding on-sale date. Ads received after the deadline will be held for the next issue unless otherwise specified. All ads must be paid in full in advance. Mail ads to: MD c/o Drum Market, 870 Pompton Ave., Cedar Grove, NJ 07009.

FOR SALE

ALL REMO, LUDWIG & EVANS Drumheads at a huge savings!!! All ZILDJIAN (including K-Brilliant and Platinum) & PAISTE cymbals at lowest prices! Huge Drumstick savings on all sticks: Pro-Mark, Vic Firth, Silver Fox, Maxx Sticks, Regal Tip, Aquarian & Duraline, and we roll 'em!!! Amazing low prices on all drums & accessories. Bizarre Guitar, 2677 Oddie Blvd., Reno, Nevada 89512 (702) 331-1001. Plus, No Sales Tax on Out of State Sales!

ELECTRONIC DRUM SALE: Simmons, Roland, Tama Techstar & Pearl kits in stock and on Sale!!! D.W., Tama & Yamaha hardware at amazing low prices!!! Bizarre Guitar, 2677 Oddie Blvd., Reno, Nevada 89512 (702) 331-1001.

DRUM MACHINE SUPER SALE: All Korg (DDD-1 & DDD-5, accessories) & Roland (including TR-707, R-8, TR-505 & TR-626), Alesis' new drum machine and all of their digital reverbs and processors on sale and in stock! Also Roland Octapad II on sale. All in stock and in quantity!!! At Unbelievable Discounted Prices! Bizarre Guitar, 2677 Oddie Blvd., Reno, Nevada 89512 (702) 331-1001.

HIGH QUALITY SUPER GLOSS DRUM COVERING AT GUARANTEED LOWEST PRICES AVAILABLE! (We've kept the same low low prices for 10 years.) Send self addressed stamped envelope for Free Samples, information and prices. Percussion Services, 3115 Hanna Ave., Cincinnati, Ohio 45211 or call (513) 661-2297. Compare, You Won't Find A Better Deal!

*****VINTAGE DRUMS*****
LEGENDARY SOUNDS - Ludwig, Slingerland & more! Choose from a huge selection! Money back guarantee. FREE CATALOG Vintage Drum Center, Route 1, Box 95B, Dept. 88, Libertyville, IA 52567. (515) 693-8691. (515) 693-3611.

Micro Torque Wrench Drum Tuner. Tune faster, accurately without having to hear drum. A quality chromed steel tool. Guaranteed. Send \$10.00 to: KITWIT, 5518 S.E. Ash, Portland, OR 97215.

BOSTON: DRUMS BOUGHT/SOLD/CONSIGNED. HERRIGAN DRUM SCHOOL. (617) 770-3837.

EAMES HAND-CRAFTED North American Birch Drum Shells. Select from Finetone, Naturaltone, or Master-tone unfinished or finished shells. Design your own instrument as only the discerning player can...For free brochure write: Eames Drums, 229 Hamilton Street, Saugus, MA 01906. (617) 233-1404.

FREE! DRUM CHARTS, CATALOG & SAMPLE! Absolutely the best! DRUM CHARTS INTERNATIONAL (Formerly STARR PRODUCTS), Box 247-F95, Nanuet, NY 10954.

ZILDJIAN, MEINL cymbals, GIBRALTAR hardware. Best prices nationwide. Send SASE or call: Jeff's Music, 571 Albany St., Little Falls, NY 13365. (315) 823-4468.

KEPLINGER SNARE DRUMS, custom sizes, Brass & Stainless. For info, send SAE to: P.O. Box 31973, Seattle, WA 98103.

WANTED: VINTAGE DRUMS! Immediate cash/trade! Vintage Drum Center, (515) 693-8691, (515) 693-3611.

KEPLINGER DRUM CO. ANNOUNCES THE "DRUM SAFE". A simple way to protect your drumset from theft. For info, send SAE to: P.O. Box 31973, Seattle, WA 98103.

SELLING YAMAHA YD9000 Recording Series Drums. Two 22 X 18, 13 X 13, 14 X 14, 18 X 16. Call Michael Kurt, (415) 355-0452.

FACTORY DIRECT PRICES! Customized, hand-made Maple Drums. America's finest quality workmanship, materials, and a wide choice of finishes. ALL AMERICAN MADE. CORDER DRUM COMPANY, 3122 12th Avenue, S.W., Huntsville, AL 35805. Phone: (205) 534-8406.

Vintage Drums: Ludwig Pioneer, piccolo, and 1924 pedal. Leedy solid maple. Duplex bass and snare. 4 X 12 mahogany snare. (501) 253-6879, evenings.

PAISTE GONG - 32" w/stand and mallet, EXCELLENT, \$600. Set of three CANNON TOMS, (10"-16"), \$300.00, EXCELLENT. Chuck (814) 266-6421.

DEALERS!!! VATER PERCUSSION INC. WORLD'S MOST DISCRIMINATING MFG. OF PRIVATE LABEL & SIGNATURE MODEL DRUMSTICKS. OFFERS THE HIGHEST QUALITY U.S.A. HICKORY AND MAPLE DRUMSTICKS AVAILABLE, GUARANTEED STRAIGHT AND DEFECT FREE. MAIL: 270 CENTRE ST., HOLBROOK, MA. 02343. TEL: 617-767-1877. FAX: 617-767-0010.

Slingerland Drums and Parts are available. Contact your favorite dealer, or write Slingerland U.S.A., Inc., P.O. Box 358, Ridgeland, S.C. 29936.

STUDY MATERIALS

ANALYTIC DRUM TUNING recommended by Russ Kunkel, *Sonor, Modern Drummer*. Complete Drum Tuning instruction. Get "Your" Drum Sound. Send \$7.95 to: Steven Walker, Box 40352, Indpls., IN 46240-0352.

TWIRL DRUMSTICKS like top Pros. No Devices Necessary! Drum Corps Trick, Easily learned. Three pages describes technique. Send \$5.50 to: Steven Walker, Box 40352, Indpls., IN 46240-0352.

BOSTON: JOHN HERRIGAN SCHOOL OF MODERN DRUMMING. (617) 770-3837.

FREE! DRUM CHARTS, CATALOG & SAMPLE! Absolutely the most Clear, Accurate charts available Anywhere! Rock, Pop, Funk, Fusion & more! New Charts released Monthly! DRUM CHARTS INTERNATIONAL (Formerly STARR PRODUCTS), Box 247-MY9, Nanuet, NY 10954.

Rent Drum Videos

Don't pay high prices for DRUMMER VIDEOS, when you can RENT THEM through the mail. Send for information. ACCENT VIDEO, #2 Kenwood Crossing, Levittown, PA 19055.

RICK'S LICKS: An innovative new book phrasing artificial groups on the drumset. The same concept used by today's leading players to create hip fills and grooves. Send \$12.50 payable to: Rick's Licks Enterprises, c/o Rick Gratton, 1388 Bathurst Street #405, Toronto, Ontario, Canada M6A 2B9, (416) 782-3646.

"THE DRUMMER'S FITNESS GUIDE" - a total physical conditioning program created especially for drummers. Over 100 pages with more than 50 safe, easy and illustrated exercises and recommendations to enhance your HEALTH, PERFORMANCE, and APPEARANCE. No matter what your present state of fitness or drumming style might be, you will certainly find this informative book practical and worthwhile. 30 DAY MONEY BACK GUARANTEE! Order from: Fit To Be Publishing, 3425

Cunnison Ln., Soquel, CA 95073. Send: ONLY \$14.95 plus \$2.00 shipping, Calif. residents add 97¢ sales tax.

CASSETTE MAIL COURSE, 10 Concepts available...Bonham, Peart, Van Halen, Moon, Aldridge, Cobham, Gadd, Rich, Bozzio, soloing. Excellent for creativity - technique. Send \$11.00 per tape (specify concept), S.A.S.E.: Jeff Indyke, 45 Kalda Lane, Plainview, NY 11803. FOR PRIVATE INSTRUCTION - (516) 681-9556.

FREE PERCUSSION EXPRESS LEARNING CATALOG - Easy Read Rock-Jazz-Fusion-Audios-Videos-Funk Session-Drumwear-Hutch Pedestal System Racks and Drums - We're your direct line to Professional Instruction. Percussion Express, P.O. Box 1731, Rockford, IL 61110. HOTLINE (815) 962-3147.

FUNK SESSION! Here's the latest electric funk music, here are the charts...YOU are the drummer! Eight exciting original charts put you in a studio situation...are you ready? \$19.95 plus \$2.00 for S&H. Percussion Express, P.O. Box 1731, Rockford, IL 61110.

AVAILABLE AT LAST! THE ONLY TUNING METHOD "YOU'LL" EVER NEED! NATIONALLY ACCLAIMED DRUM TECH. WITH 17 YEARS EXPERIENCE, IS FINALLY GIVING AWAY HIS SECRET! SIMPLE STEP BY STEP INSTRUCTION, WITH ILLUSTRATIONS, WILL GUIDE YOU. CAN "YOU" AFFORD NOT TO HAVE THE HOTTEST SOUND?! SEND TODAY! \$7.97 TO: RON STRENGER, BOX 12561, NEW BRIGHTON, MN 55112-9998.

VOCAL EXERCISES on cassette. Practice singing at home. For a stronger voice, expanded range, more confidence. \$19.95. Harmony training - \$14.95. CHROMOTONE, 1070R Detroit, Denver, CO 80206.

20 Popular Rudiments cassette package with booklet. Send \$5.00 to: SLW, 30137 Anenida Tranquila, R.P.V., CA 90274.

DRUM TUNING—A Comprehensive Guide to Tuning Drums. Send \$7.95 check or M.O., no cash, to: Drumstick Publishing, P.O. Box 9216, Dept. MD, Wilmington, DE 19809-9216.

Attention Drummers! "Drum Control With Sixteenth Notes", book and video, \$39.95. For excellent-creative fill-ins and solos! The book is recommended by: Louie Bellson, Ed Shaughnessy and Ed Thigpen. The Video is 68 minutes and shows 203 fill-ins. Also available, "Drum Control With Triplets" book, \$6.35, same recommendations as above. Send money to: Dennis Venuti, 1212 Mollhore Terrace, Philadelphia, PA 19148.

INSTRUCTION

BOSTON AREA: QUINCY, WEYMOUTH, NORWELL, MARSHFIELD, JOHN HERRIGAN SCHOOL OF MODERN DRUMMING, ALL STYLES, ALL LEVELS, MESSAGE: (617) 770-3837 or Home (617) 472-6672.

In the S.F. Bay area John Xepoleas, author of *Studies For The Contemporary Drummer*, is accepting serious students. Develop the skills needed for today's drumming. (415) 947-2066.

SCHOOL FOR MUSICAL PERFORMANCE. Specializing in Percussion: Drumset, Vibraphone and Marimba 4 mallet technique. Private instruction for ALL instruments, Voice, Theory and songwriting. Musical Director, David Kovins, B.A., M.A., M.S.M., 910 Kings Highway, Brooklyn, NY 11223 (718) 339-4989.

STUDY WITH DRUM CHARTS! FREE CATALOG & SAMPLE! DRUM CHARTS INTERNATIONAL (Formerly Starr Products), Box 247-195, Nanuet, NY 10954.

Balto. Grant Meneffe Studio of Drumming, B.M. Berkle College of Music, Towson State University Instructor. Drums recovered. (301) 747-STIX.

REGISTER EARLY! ANNUAL SUMMER DRUM SET WORKSHOP. TWO LOCATIONS - CAPITAL UNIVERSITY, Columbus, Ohio, June 12-16. UNIVERSITY OF UTAH, Salt Lake City, Utah, July 17-21. FACULTY: ED SOPH, STEVE HOUGHTON, GUY REMONKO, BOB BREITHAAPT. Private and group lessons, listening, basic musicianship, and history of drum set classes, commercial styles, chart reading, video tape sessions and other intensive classes. Contact: SUMMER DRUM SET WORKSHOP, Capital University, Columbus, Ohio 43209; (614) 236-6474, or SUMMER DRUM SET WORKSHOP, Department of Music - University of Utah, Salt Lake City, Utah 84112; (801) 581-6398.

Drummers: Learn All styles of drumming on all the percussion instruments, including drumset and mallets. John Bock Percussion Studio (914) 592-9593.

"Visual Aids" the book of showmanship that helps create pros. Book has 8 chapters spanning 42 pages. Completely illustrated. To order send \$10.00 plus \$2.00 shipping and handling (\$12.00 total) to: "Visual Aids", P.O. Box 294, Winter Haven, FL 33882-0294. Allow 4-6 wks. for delivery. Foreign orders add \$2.00.

WANTED

BOSTON: DRUMS BOUGHT/SOLD/CONSIGNED. HERRIGAN DRUM SCHOOL. (617) 770-3837.

WANTED: DRUMMERS TO RECEIVE FREE DRUM CHARTS CATALOG! DRUM CHARTS INTERNATIONAL (Formerly Starr Products), Box 247-WM9, Nanuet, NY 10954.

VINTAGE DRUMS! Immediate cash/trade. Vintage Drum Center, (515) 693-8691, (515) 693-3611.

DRUMMERS WANTED to send for FREE DISCOUNT CATALOG. Drumshine, 8622 Reading Rd., Cincinnati, Ohio, 45125.

VINTAGE DRUMS

The legendary sound you want!
Choose from one of the country's largest selections of vintage snare drums.

**WE BUY
SELL & TRADE**

- Slingerland Radio Kings
- Ludwig Black Beauties
- Leedy, Gretsch & more!

Call for our free catalog

(515) 693-8691 (515) 693-3611

VINTAGE DRUM CENTER
ROUTE 1 #95 LIBERTYVILLE, IA 52567

Glenn Weber Drum Shop
Housing the
New Jersey School of Percussion
Lessons • Sales • Service

**Special Savings
on Drum Sets, Congas
and Cymbals!**

16 Northfield Ave., West Orange, N.J. 07052
(201) 736-3113

DRUMMERS! DRUM RECOVERING KITS AVAILABLE. Over 25 choices of Pearls, Sparkles, Satin Flames and Woodgrains. Send \$1.00 for full information and samples (refundable on first order). **PRECISION DRUM COMPANY**, Dept. C, 151 California Road; Yorktown Heights, N.Y. 10598

VATER PERCUSSION

Quality Custom Label Drumsticks

STORE NAME'S AND LOGO'S

Tel. # 617-767-1877 FAX: 617-767-0010

PLEASE SEE CLASSIFIED

Drum Stick Necklace



Pair mini gold-plated drum sticks on fine chain. For him/her. Cymbal, Side Drum, & Timpaini pins. Side Drum necklace & Drum earrings. **Elegant! Looks expensive!** Only \$11.95. Two-\$22. Add \$1.50 postage. Gift boxed. \$\$ Back Offer

IMPERIAL, 16221 State Road #7, Delray Beach, FL 33447

Valley Drum Shop

EVERYTHING FOR THE DRUMMER
Sales • Service • Repairing

New & Used Drums,
Cymbals, Sticks,
Heads, Parts, and
More.

We Build the Famous
Custom 7 x 14, 5 1/2 x 14,
and 4 x 14 Maple Snare
Drum Known world wide.



Go Where The Pros Go!

818-994-1755 13636 Burbank Blvd.
Van Nuys, CA 91401

Waddell's

cymbal warehouse

Zildjians, A, K, Z, Amir,
Scimitar, Brilliants and Platinums
on stock and ready to ship!

Wholesale Prices
Satisfaction Guaranteed

Call or write for Free Flyer:

P. O. Box 106 • Leechburg, PA 15656 412/845-6088

JOIN NOW!

THE DRUM CLUB
sponsored by

GRANT'S DRUM CITY

SEND \$10.00 FOR 1 YEAR MEMBERSHIP
AND RECEIVE

- * EXCLUSIVE DISCOUNTS ON DRUM EQUIPMENT
- * 1 PR. OF OFFICIAL G.D.C. STICKS
- * 1 G.D.C. BUMPER STICKER
- * 1 G.D.C. PICTURED CATALOG

WRITE OR CALL NOW!
GRANT'S DRUM CITY
426 EAST IRVING BLVD.
IRVING, TEXAS 75060
1-214-438-1581



PERCUSSION PARADISE

- Sales
- Repairs
- Instruction

"Drums Galore
Everything Your Mind
Can Imagine
and More"

(718) 667-3777

203 Old Town Rd., Staten Island, NY 10305

Send \$1.00 for 46 page Catalog.

Paradise Awaits You!!



Ask your music store for:
LUG LOCK & GIG RUG™

We are the only company addressing the equipment problems you face every time you play.

Write for free brochures, sticker, and info on our patented Quick Stand™ the ONLY automatic high-hat stand.



L.T. Lug Lock, Inc.

Box 204, Tonawanda, NY 14151
716/695-5881

"PRACTICAL SOLUTIONS"
Patents Pending

**REPRINTS of most
MD Feature Articles
and columns ARE
available! Call the
office for a
price quote**



**THE
WOODWIND
& THE
BRASSWIND**
announces it's

**ALL
NEW
FREE
DRUM
CATALOG**

CALL: (219) 272-8266

50741 U.S. 31 N., South Bend, IN 46637

Profiles in Percussion

Dave Mattacks

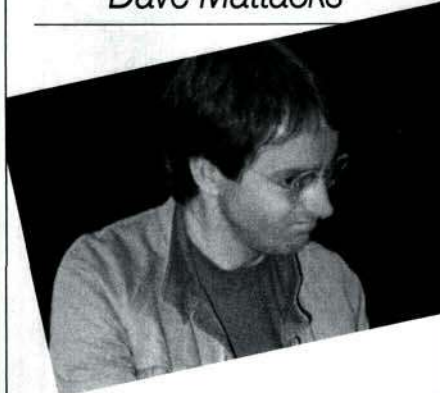

After leaving school, Dave Mattacks served as an apprentice piano tuner in London, England. In 1969, he joined "FAIRPORT CONVENTION," recording seven albums.

Dave became one of the busiest musicians on the session scene in London becoming almost the resident drummer in many top studios. He has recorded with literally thousands of artists including, ELTON JOHN, PAUL McCARTNEY, RICHARD THOMPSON, CHRIS REA and GEORGE HARRISON.

Since the mid 80's when "FAIRPORT CONVENTION" reformed, Dave has combined session work with the group's active schedule. Dave plays drums and keyboards on their most recent albums and even produced the latest—"IN REAL TIME."

Dave has used Zildjian cymbals all his life. His current set-up includes cymbals from each of Zildjian's 'cast' cymbal ranges 'A's and 'K's and 'Z's.

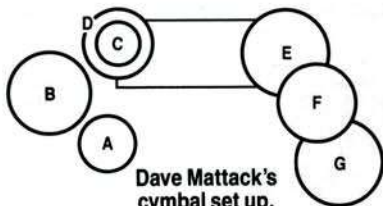

Dave Mattack's cymbal set up.

- A: 13" Special K/Z HiHats
- B: 19" K China Boy Brilliant
- C: 10" K Splash Brilliant (on top of D)
- D: 16" A Medium Thin Crash Brilliant
- E: 20" Z Light Power Ride
- F: 18" A Medium Thin Crash Brilliant
- G: 20" A China Boy High Brilliant (with rivets)

Zildjian®
The only serious choice.

Avedis Zildjian Company
Longwater Drive, Norwell, MA 02061

© 1989 Avedis Zildjian Company

next month in
JUNE'S MD...



Photo by Lissa Wales

MICHAEL SHRIEVE

KINGDOM COME'S

JAMES KOTTAK

TREVOR TOMKINS

Plus columns by:

Peter Erskine

John Santos

Peter Magadini

and much more...
don't miss it!

ADVERTISER'S INDEX

Action/Reaction	69
AKG Acoustics	57
Mike Balter Mallets	45
Sam Barnard	81
Berklee College of Music	64
Beyer Mics	50
Calato/Regal Tip	88
Canasonic Drumheads	45
Corder Drum Company	62
DC1000 Percussion	56
DCI Music Video	67,72,97
ddrum	89
Drummers Collective	76
Drum/Keyboard Shop	85,98
Drumstix	50
Drum Workshop	17,81
Duratech Music Products	48
Dynacord	99
Evans Products	1
Explorer's Percussion	68,76
Chas. E.Foote, Ltd.	100
GC Music	101
Grant's Drum City	107
Great American Drumstick Co.	76
Gretsch Drum Co.	Inside Back Cover
Hot Licks Productions	70
Imperial	107
Jemm Company	94
Kaman Music Distributors	51,83
KAT	54
Kettles & Company	84
Long Island Drum Center	101
Ludwig Industries	Inside Front Cover,59
LT. Lug Lock	107
MD Back Issues	87
MD Library	77
Musician's Institute	91
Noble & Cooley	98
Paiste	36/37
Pearl International	13,14/15,42,55
Percussion Paradise	107
Precision Drum Co.	107
Premier Percussion USA	5
Pro Mark	63,67,84
PureCussion	11
Paul Real Sales	93
Remo	49,71,82
Resurrection Drums	90
RIMS	85
Rimshot America	80
Sabian	52/53
"Set The Pace" Pedal Practice Pads	88
Shark	54
Shure Bros.	95
Simmons Electronics USA	35,105
Sonor Percussion	43
Tama	9,39,80
Thoroughbred Music	73
Tropical PROductions	56
Valley Drum Shop	107
VaterPercussion	73,107
Vic Firth, Inc.	65
Vintage Drum Center	107
Waddell's Cymbal Warehouse	107
Glenn Weber Drum Studio	107
The Woodwind & The Brasswind	107
Yamaha	6,7
Zildjian	62/63,108,Outside Back Cover

Why do I play Gretsch?

Phil Collins
Genesis, producer & solo artist

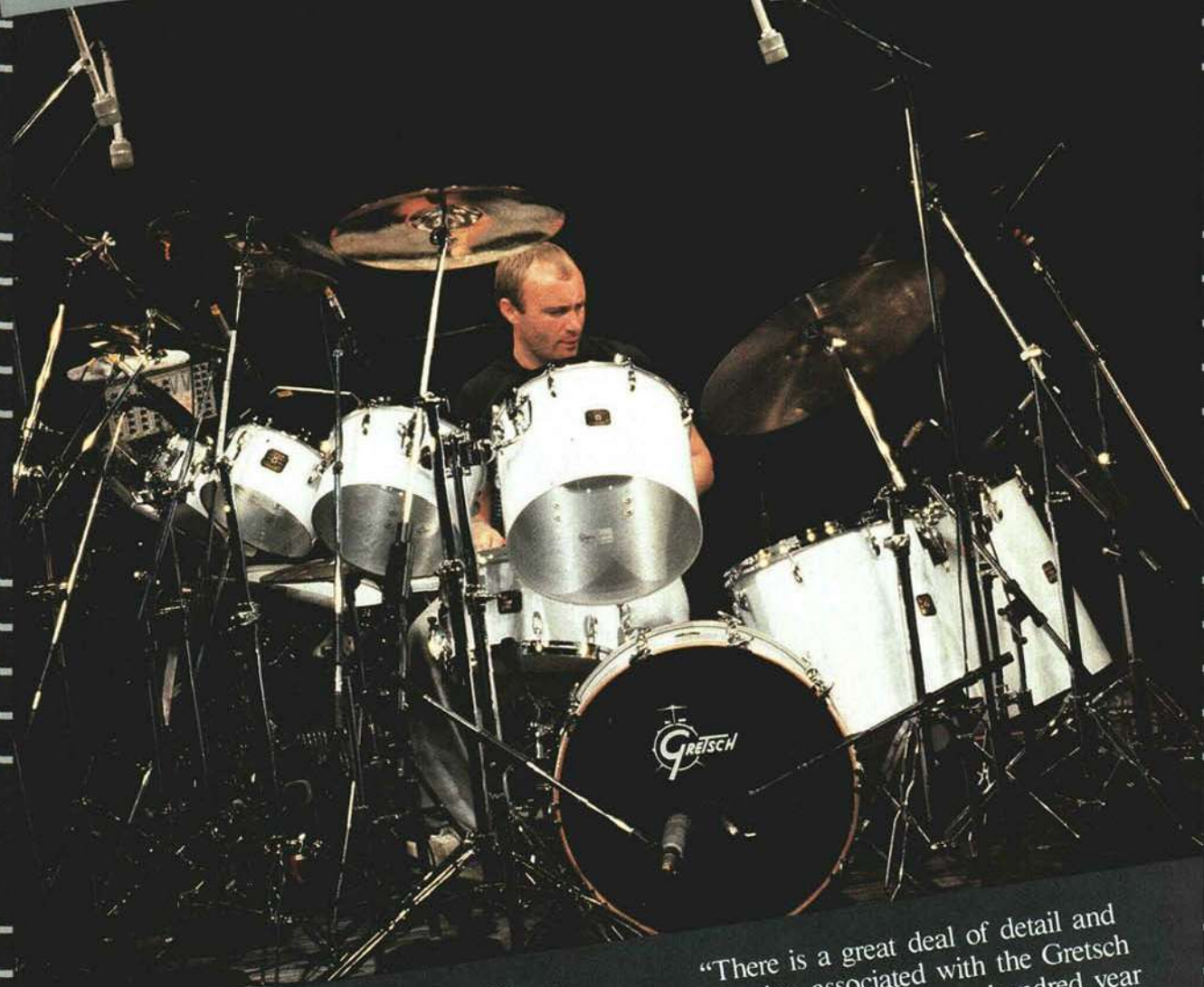

"When I was about fourteen or fifteen years old, a good friend of mine who was playing drums in Joe Cocker's grease-band was playing Gretsch. I persuaded him to sell me his kit. From that moment, I was a Gretsch player. I still own that kit and it still sounds great today."

"Gretsch has always been 'a drummer's drum' and when the opportunity developed allowing me to play Gretsch again, I jumped at the chance."

"There is a great deal of detail and sophistication associated with the Gretsch product, name and over one-hundred year heritage. Sometimes I wish I did everything as well as they do."

"How do I like my new drums? They're beautiful in sound and looks...And most important, they're Gretsch."



Someday, you'll own Gretsch.

1 Gretsch Plaza • Ridgeland, S.C. 29936 • (803) 726-8144 • TELEX: 386628 (Gretsch) ENT UD

For a color poster of Phil Collins, send a \$3.50 check or money order to Gretsch Poster #5, 1 Gretsch Plaza, Ridgeland, SC, 29936. copyright © 1983 Gretsch, Inc.

TRADITION AND TECHNOLOGY.

It doesn't have to be
an either/or situation.
Some things are new
and have to change fast.
Like the computer.
Some ideas
have been around awhile
and can only be refined.
Like the bicycle.
Like the cymbal.
Avedis Zildjian.
Tradition and innovation
for over 365 years.

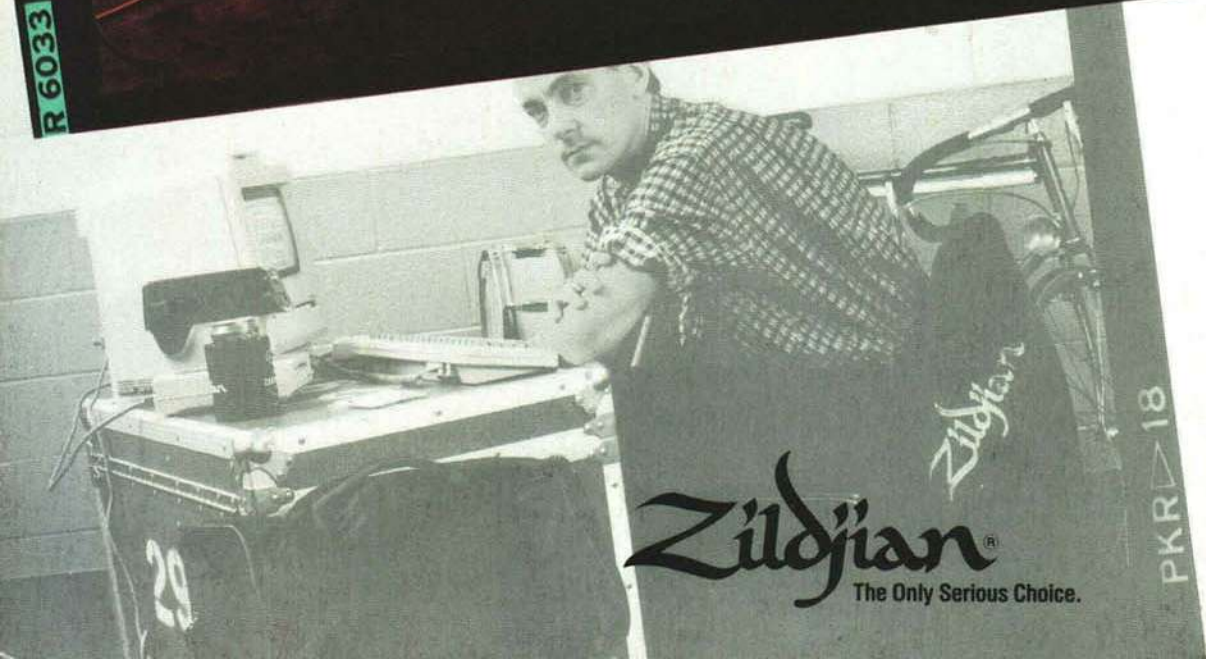

Zildjian[®]
The Only Serious Choice.